



This is a digital copy of a book that was preserved for generations on library shelves before it was carefully scanned by Google as part of a project to make the world's books discoverable online.

It has survived long enough for the copyright to expire and the book to enter the public domain. A public domain book is one that was never subject to copyright or whose legal copyright term has expired. Whether a book is in the public domain may vary country to country. Public domain books are our gateways to the past, representing a wealth of history, culture and knowledge that's often difficult to discover.

Marks, notations and other marginalia present in the original volume will appear in this file - a reminder of this book's long journey from the publisher to a library and finally to you.

Usage guidelines

Google is proud to partner with libraries to digitize public domain materials and make them widely accessible. Public domain books belong to the public and we are merely their custodians. Nevertheless, this work is expensive, so in order to keep providing this resource, we have taken steps to prevent abuse by commercial parties, including placing technical restrictions on automated querying.

We also ask that you:

- + *Make non-commercial use of the files* We designed Google Book Search for use by individuals, and we request that you use these files for personal, non-commercial purposes.
- + *Refrain from automated querying* Do not send automated queries of any sort to Google's system: If you are conducting research on machine translation, optical character recognition or other areas where access to a large amount of text is helpful, please contact us. We encourage the use of public domain materials for these purposes and may be able to help.
- + *Maintain attribution* The Google "watermark" you see on each file is essential for informing people about this project and helping them find additional materials through Google Book Search. Please do not remove it.
- + *Keep it legal* Whatever your use, remember that you are responsible for ensuring that what you are doing is legal. Do not assume that just because we believe a book is in the public domain for users in the United States, that the work is also in the public domain for users in other countries. Whether a book is still in copyright varies from country to country, and we can't offer guidance on whether any specific use of any specific book is allowed. Please do not assume that a book's appearance in Google Book Search means it can be used in any manner anywhere in the world. Copyright infringement liability can be quite severe.

About Google Book Search

Google's mission is to organize the world's information and to make it universally accessible and useful. Google Book Search helps readers discover the world's books while helping authors and publishers reach new audiences. You can search through the full text of this book on the web at <http://books.google.com/>



3 3433 06634366 0



VGA
Institution

JOURNAL

OF THE

SOCIETY OF TELEGRAPH ENGINEERS,

INCLUDING

ORIGINAL COMMUNICATIONS ON TELEGRAPHY AND
ELECTRICAL SCIENCE.

PUBLISHED UNDER THE SUPERVISION OF THE EDITING COMMITTEE,

AND EDITED BY

LIEUT.-COL. FRANK BOLTON, C.E., HON. SECRETARY,

AND

WILLIAM EDWARD LANGDON, ACTING SECRETARY.

VOL. VI.—1877.

London:

E. AND F. N. SPON, 46, CHARING CROSS.

New York:

446, BROOME STREET.

1877.

1819

The Society of Telegraph Engineers.

ESTABLISHED 1871.

COUNCIL, 1877.

President.

PROFESSOR ABEL, F.R.S. *President of the Chemical Society.*

Past-Presidents.

C. V. WALKER, F.R.S.

LATIMER CLARK, C.E.

SIR WILLIAM THOMSON, F.R.S., LL.D.

FRANK IVES SCUDAMORE, C.B.

CHARLES WILLIAM SIEMENS, F.R.S., D.C.L.

Vice-Presidents.

MAJOR J. U. BATEMAN-CHAMPAIN, R.E.

PROFESSOR G. C. FOSTER, F.R.S.

W. H. PREECE, M.I.C.E.

CARL SIEMENS, M.I.C.E.

Members.

PROFESSOR W. G. ADAMS, F.R.S. : CHARLES HOCKIN, M.A., C.E.

CAPTAIN ANDERSON, B.E. : LOUIS SCHWENDLER, *Member of*
CAPTAIN ARMSTRONG, R.E. : *Council of the Asiatic Society.*

G. VON CHAUVIN. WILLOUGHBY SMITH.

H. G. ERICHSEN. C. E. SPAGNOLETTI, M.I.C.E.

COLONEL GLOVER, R.E. C. F. VARLEY, F.R.S., M.I.C.E.

EDWARD GRAVES.

Associates.

FREDERICK HIGGINS. | H. R. KEMPE.

E. T. TRUMAN.

OFFICERS.

Auditors.

J. WAGSTAFF BLUNDELL, 16, Gresham Street, E.C.

FREDERICK C. DANVERS (India Office).

Treasurers (pro tem.) Hon. Secretary.

Messrs. COCKS, BIDDULPH, & Co., LIEUT.-COL. FRANK BOLTON,
43, Charing Cross, S.W. 4, Broad Sanctuary, S.W.

Hon. Solicitors.

Messrs. WILSON, BRISTOWS, & CARPMAEL, 1, Copthall Buildings, E.C.

Acting Secretary.

WM. EDWARD LANGDON, 4, Broad Sanctuary, Westminster, S.W.

Bankers.

Messrs. COCKS, BIDDULPH, & Co., 43, Charing Cross, S.W.

TABLE OF CONTENTS.

VOL. VI.

	PAGE
Proceedings of Meeting held on Wednesday, 24th January, 1877 :—	
President's Inaugural Address	3
Proceedings of Meeting held on Wednesday, 14th February, 1877 :—	
Paper "On Shunts, and their application to Electrometric and Telegraphic purposes," by W. H. Preece, M.I.C.E. Vice-President	27
Proceedings of Meeting held on Wednesday, 28th February, 1877 :—	
Paper "On Fire Telegraphs," by R. von Fischer Treuenfeld, F.R.G.S. ...	75
Discussion on above Paper	116
Proceedings of Meeting held on Wednesday, 14th March, 1877 :—	
Paper "On the Automatic Step-by-Step Type-Printing Telegraph Apparatus used by the Exchange Telegraph Company," by F. Higgins ...	122
Description of the Autokinetic System in application to Fire Alarms ...	143
Adjourned Discussion on Mr. Treuenfeld's paper "On Fire Telegraphs"...	147
Proceedings of Meeting held on Wednesday, 28th March, 1877 :—	
Presentation of Portrait of Sir William Fothergill Cook, by Mr. Lat' ner Clark	160
Resignation of Treasurer	160
" Acting Secretary	160
Appointment of Successors	161
Adjourned Discussion on Mr. Higgins's Paper	161
Paper "On Underground Telegraphs," by Willoughby Smith	162
Paper "On Underground Telegraphs in France," by John Aylmer, Civil Engineer, Hon. Secretary for France	170
Discussion on above Papers	177
Proceedings of Meeting held on Wednesday, 11th April, 1877 :—	
Paper "On Quadruplex Telegraphy," by G. B. Prescott	189
Description of M. Ailhaud's System for Duplex Working in operation on the Marseilles-Algiers Cable"	205
Discussion on above Papers	209
Associates advanced to Membership	26, 159, 214
New Members... ..	26, 73, 159, 214, 319, 490
ORIGINAL COMMUNICATIONS :—	
"Note on Electro-Magnets employed in Telegraphy," by Emile Lacoine...	215
"On Electro-Magnets for use in Telegraphy," by Emile Lacoine... ..	218
"Telegraphy in New Zealand," by W. H. Floyd	226

LOCAL HONORARY SECRETARIES.

DON JOSÉ APARICIO, 70, dup. Calle de Pelayo, Madrid	}	SPAIN
JOHN AYLMER, Civil Engineer, 4, Rue de Naples, Paris	}	FRANCE.
W. E. AYRTON, Professor of Natural Philosophy, Imperial College, Tokei, Japan	}	JAPAN.
CHARLES BURTON, A.I.C.E. Telegraph Engineer, Buenos Ayres	}	ARGENTINE REPUBLIC
J. M. COLLETTE, Engineer of the Netherlands Telegraphs, The Hague	}	The NETHERLANDS.
E. C. CRACKNELL, Superintendent of the New South Wales Telegraphs, Sydney	}	NEW SOUTH WALES.
Le Commandeur E. D'AMICO, Director-General of the Italian Telegraphs, Rome	}	ITALY.
FRÉDÉRIC DELARGE, Engineer of the Belgian Tele- graphs, Brussels	}	BELGIUM.
C. L. MADSEN, Great Northern Telegraph Com- pany, Copenhagen	}	DENMARK.
C. NIELSEN, Director-General of the Norwe- gian Telegraphs, Christiania	}	NORWAY.
COL. D. G. ROBINSON, R.E. Director-General of the Indian Telegraphs, Calcutta	}	INDIA.
Dr. WERNER SIEMENS, Berlin	}	GERMANY.
DON RAMON VIAL, Director-General of the Chilian Telegraphs, Santiago	}	CHILI.
G. G. WARD, Gen. Superintendent of the Direct United States Cable Company, New York	}	NORTH AMERICA.

TABLE OF CONTENTS.

VOL. VI.

	PAGE
Proceedings of Meeting held on Wednesday, 24th January, 1877 :—	
President's Inaugural Address	3
Proceedings of Meeting held on Wednesday, 14th February, 1877 :—	
Paper " On Shunts, and their application to Electrometric and Telegraphic purposes," by W. H. Preece, M.I.C.E. Vice-President	27
Proceedings of Meeting held on Wednesday, 28th February, 1877 :—	
Paper " On Fire Telegraphs," by R. von Fischer Treuenfeld, F.R.G.S. ...	75
Discussion on above Paper	116
Proceedings of Meeting held on Wednesday, 14th March, 1877 :—	
Paper " On the Automatic Step-by-Step Type-Printing Telegraph Apparatus used by the Exchange Telegraph Company," by F. Higgins ...	122
Description of the Autokinetic System in application to Fire Alarms ...	143
Adjourned Discussion on Mr. Treuenfeld's paper " On Fire Telegraphs"...	147
Proceedings of Meeting held on Wednesday, 28th March, 1877 :—	
Presentation of Portrait of Sir William Fothergill Cook, by Mr. Lat' ner Clark	160
Resignation of Treasurer	160
" Acting Secretary	160
Appointment of Successors	161
Adjourned Discussion on Mr. Higgins's Paper	161
Paper " On Underground Telegraphs," by Willoughby Smith	162
Paper " On Underground Telegraphs in France," by John Aylmer, Civil Engineer, Hon. Secretary for France	170
Discussion on above Papers	177
Proceedings of Meeting held on Wednesday, 11th April, 1877 :—	
Paper " On Quadruplex Telegraphy," by G. B. Prescott	189
Description of M. Ailhand's System for Duplex Working in operation on the Marseilles-Algiers Cable"	205
Discussion on above Papers	209
Associates advanced to Membership	26, 159, 214
New Members... ..	26, 73, 159, 214, 319, 490
ORIGINAL COMMUNICATIONS :—	
" Note on Electro-Magnets employed in Telegraphy," by Emile Lacoine... ..	215
" On Electro-Magnets for use in Telegraphy," by Emile Lacoine... ..	218
" Telegraphy in New Zealand," by W. H. Floyd	226

	PAGE
ABSTRACTS AND EXTRACTS:—	
“The Importance of a General System of Simultaneous Observations of Atmospheric Electricity,” by W. E. Ayrton and John Perry	242
“A Duplex Partial-Earth Test,” by W. E. Ayrton and John Perry	251
Proceedings of Meeting held on Wednesday, 25th April, 1877:—	
Paper “On Batteries,” by Martin F. Roberts, F.C.S.	257
Discussion on above Paper	273
Proceedings of Meeting held on Wednesday, 9th May, 1877:—	
Paper “On Double Current Translation,” by Gustav Risch	284
Description of a New Form of Electric Light, by the Acting Secretary ...	303
Discussion thereon	317
ORIGINAL COMMUNICATIONS:—	
“Abstracts and Information regarding Soundings taken with Sir William Thomson’s Apparatus on the West Coast of South America,” by H. Benest	320
“Description of combined Key and Switch,” by Andrew Jamieson ...	330
Arrangement of Connections necessary for Employment with Sir William Thomson’s Recorder or Speaking Galvanometer	334
“On Unifilar Suspension,” by W. E. Ayrton and John Perry	335
“On the Principles to be observed in the Erection of Wires over Long Spans,” with Tables, by R. S. Brough	337
“Improved Make and Break Arrangement for Sir William Thomson’s Recorder Mill,” by James Graves	357
“On the General Theory of Duplex Telegraphy,” by Louis Schwendler... ..	316
“On a Case of Lightning; with an Evaluation of the Potential and quantity of the Discharge in Absolute Measure,” by R. S. Brough ...	378
Proceedings of Special General Meeting held 31st October, 1877:—	
“Researches in Electric Telephony,” by Professor A. Graham Bell ...	385
Proceedings of Ordinary General Meeting held 28th November, 1877:—	
Paper—“Selenium, its Electrical qualities, and the Effect of Light thereon,” by Willoughby Smith	423
Discussion on above Paper	441
Paper—“On the Measurement of Currents,” by W. H. Preece, Vice-President, M.I.C.E.	448
Discussion on the above	452
Associates and Students advanced	454, 490
Proceedings of Ordinary and Annual General Meeting held 12th December, 1877:—	
Annual Report	456
Balance Sheet	466
Paper on “Earth-Currents on Land Lines,” by A. J. S. Adams	468
Discussion on above Paper	475
Paper on “Sonorous Properties of Electrostatic Induction,” by A. J. S. Adams... ..	476
Discussion thereon	480
Addendum	484
Result of Ballot for Officers and Council	488
Modification of Rule 24... ..	488

CONTENTS.

v

	PAGE
OBITUARY :—	
Major-General D. G. Robinson... ..	492
Ruhmkorff	496
ORIGINAL COMMUNICATIONS :—	
“Researches on Selenium,” by Dr. Engen Obach	498
“A New and Practical Application of the Telephone,” by Elisha Gray, Sc.D. ...	506
“Earth-Currents,” by S. M. Banker	519
“Employment of Old Railway Metals for Telegraph Poles,” by R. G. B. Davids	520
“A New Wire-Finder,” by John Gott	522
ABSTRACTS AND EXTRACTS :—	
“On the General Theory of Duplex Telegraphy,” by Louis Schwendler... ..	524
“The Kaffir War and the Telegraph”	544
APPENDIX :—	
Letter from W. F. Channing on the Telephone	545

JOURNAL

OF THE

SOCIETY OF TELEGRAPH ENGINEERS.

VOL. VI.

1877.

Nos. 17 AND 18.

The Fifty-second Ordinary General Meeting was held on Wednesday, the 24th day of January, 1877, Professor ABEL, F.R.S., President, in the Chair.

Mr. C. V. WALKER, for the moment in the Chair, after the transaction of the usual preliminary business, said :—

Gentlemen,—I retire from this position after a session that has been very successful in every respect. The success is through no personal merit of mine. There is nothing in the session just past to which we can look back with regret, and I am confident that with respect to the session now about to commence we shall have still less reason for a gloomy retrospect when by effluxion of time Professor Abel, whom I have now the honour of introducing as your President for the ensuing year, shall in his turn retire.

Mr. C. W. SIEMENS: Gentlemen, before the President elect favours us with his address I have one motion to propose which I am certain will meet with general approbation—that is, to give a hearty vote of thanks to our past President, Mr. Walker. (Applause). Mr. Walker has given a very great deal of close attention to the duties which he undertook a year ago, and I can say from my own experience it is a somewhat anxious task to take the chair in a young Society, which one feels ought to be progressing and become a large and important Society. I think, under the direction of the

late President, the Society has gone on increasing in numbers and importance; and I therefore have great pleasure in proposing a vote of thanks to Mr. Walker for his conduct in the chair of this Society during the past twelve months.

Mr. LATIMER CLARK: I have great pleasure in seconding the proposition of Dr. Siemens. Mr. Walker began electricity and telegraphy almost before any of us. He is one of the oldest well-known electricians of this country, and we ought to congratulate him on the great success with which he has conducted his presidency, and for the example of punctuality which he has set us by his attendance at the meetings of the Society. He has, moreover, given us some very valuable papers, especially his opening address, in which he gave us some extremely interesting statements in connection with the early history of telegraphy.

The motion was carried by acclamation.

Mr. C. V. WALKER: Gentlemen, I beg to thank you very sincerely for the hearty manner in which the members have responded to this kind proposition. I can assure our new President, Professor Abel, that the duties of President of this Society are by no means so heavy as my kind friends on my left would make it appear. So long as we have a staff of officers like those now present the duties will be rendered so exceedingly light that he will find himself from the commencement to the end of the session getting through his work with very little anxiety and fatigue. The only thing for which I can personally claim credit, important though it may be, is simple, and at the command of most of us—is having endeavoured to be regular and punctual in my attendance at all meetings. Happily, no exception to the uniform good health that is mine, nor any other cause, has prevented my being present at every Meeting of Council and of Members during my period of office, and taking the chair punctually when the time has arrived. (Applause). I thank you again, gentlemen, for the kind manner in which you have been pleased to acknowledge my humble services.

The President then proceeded to read his Inaugural Address.

INAUGURAL ADDRESS

BY PROFESSOR ABEL, F.R.S., *Pres. Chem. Soc.*,

PRESIDENT.

GENTLEMEN,

The rapidity, almost unprecedented, with which the Society of Telegraph Engineers has attained a position of importance among the more prominent associations of workers in applied science, must be in a great measure ascribed to the wisdom hitherto exercised by its members in the selection of the men whom they have honoured by entrusting them with the management of its affairs. Few young institutions have been so fortunate in the possession of Officers and Members of Council, who, with such indefatigable zeal and determination, have made its interests their labour of love, and none can boast of a succession of Presidents more distinguished in immediate connection with the profession and the scientific pursuits of those who, in delighting to honour these eminent men, have, at the same time, given lustre to the chair of this Society, and taken the wisest steps towards raising and maintaining their Association in the proud position which it now occupies among its kindred.

For once, the Society has laid itself open to have its wisdom or prudence questioned, by electing to the honourable and important office of its President an individual who can lay no claim whatever to any of the high qualifications which have rendered his predecessors in that office specially deserving of the honour conferred upon them, and peculiarly fitted to promote the interests of the Society. If to have contributed nothing to the pure science of

electricity, to have done nothing towards the advancement of telegraphy and the development of telegraph-engineering, are henceforth to be considered no disqualification for the post which has been filled by such men as Siemens, Scudamore, Thomson, Clark, and Walker, then, indeed, what must be regarded as the new-born liberality of your views on this important subject has been most happily illustrated by my election to this chair.

My humble labours in connection with applications of electricity, analogous certainly in their nature to those developed and applied by the telegraph engineer, but sadly different in respect to the benefits they are calculated to confer upon mankind, should indeed hardly be regarded as constituting a sufficient claim to the privilege of enrolment among your body; the wildest flight of imagination could therefore not have suggested to me, when you accepted me as a member, the possibility of my attaining to the high distinction of the presidency, and I must crave your belief in the sincerity of my statement that I have greatly hesitated as to whether I should presume to accept that honour. Having earnestly sought for a justifiable ground for my selection by you, I can only admit to myself the validity of the single one, that it is your desire, by that act, formally to testify your recognition of the special importance of chemical science in its application to telegraphy, and of the benefits which the telegraph-engineer has already reaped, and may still hope to reap, from the labours of the scientific and practical chemist.

So strong is my conviction that to this consideration I owe the privilege of addressing you this evening, that I feel confident of rightly interpreting your wishes if I endeavour to illustrate some of the principal directions in which chemical science bears importantly upon the work of the telegraph engineer. And, to commence with, I can select no better illustration of the value of combining chemical with electrical research than that furnished by the investigations of the late Dr. Matthiessen, relating to the causes of the differences in electrical conductivity exhibited by different kinds of commercial copper, which were undertaken at the instance of the Joint Committee appointed by the Lords of the Com-

mittee of Privy Council for Trade and the Electric Telegraph Company, and were published in the valuable Blue Book prepared in 1861 by that Committee.

The very great variations which were found to exist in the copper wire employed in the earlier days of submarine telegraphy had already been traced by Sir William Thomson and other experimenters to the differences in the quality of the copper, but it was evident to the Committee that a complete investigation of the subject must furnish results not only of scientific interest but of considerable practical importance, and they therefore entrusted this work to Dr. Matthiessen, who had already published valuable researches on the constitution and properties of various alloys. By a systematic series of very carefully-conducted experiments, that accomplished chemist examined, in the first instance, the influence exerted upon the conducting power of pure copper (prepared with great care by electrolysis) by the principal metalloids and metals known to be naturally associated with it, and afterwards determined the conducting powers of important varieties of commercial copper, the impurities in which were then ascertained by analysis, whereby it became possible to assign to the true causes the great differences in their value as conductors of the different descriptions of copper occurring in commerce.

In illustration of the importance of the facts established by these experiments of Dr. Matthiessen, I may mention that the conducting power of pure copper was found *not* to be susceptible of increase by alloying or combining the metal with any other substance, and that certain non-metallic elements, occurring as constant or very frequent impurities in copper of commerce (notably oxygen and arsenic), exerted a very prejudicial influence upon the conducting power of the metal. Thus, the conductivity of pure galvano-plastic copper being fixed at 100, the addition of only traces of arsenic to the metal reduced its conductivity to 60, while a specimen into which 5 per cent. had been introduced had a conductivity of only 6·5. The fusion of the pure metal in contact with air for a short time reduced its conductivity to 76: the *amount* of oxygen, or sub-oxide of copper, taken up by the copper

in these experiments, or existing in the various samples examined by Matthiessen, could not be ascertained with any accuracy, as no trustworthy method existed at that time for estimating the oxygen in copper, a requirement which, three years subsequently, I myself was enabled to supply after an extensive investigation.

The conductivity of copper was found by Matthiessen to be not so much impaired by the presence of small quantities of other metals as by the non-metallic impurities, but it was shown to be considerably diminished by iron and tin. Thus, the existence of 1·3 per cent. of tin in the pure metal reduced its conductivity to 50·4, and, with only 0·48 per cent. of iron, its conductivity was as low as 36.

Some specially interesting experiments of Matthiessen, when considered in conjunction with experiments made in a similar direction by other chemists, served importantly to elucidate the cause of the good effects long since observed to be produced upon the working qualities of refined copper by the addition of small quantities of lead, and afford an excellent illustration of the advantages to be derived from the application of chemical knowledge to the elucidation of many manufacturing operations which, based originally upon accidental observations, have continued to be practised in a precarious rule-of-thumb fashion, with correspondingly uncertain results, until they have acquired the precision and perfection essential to that uniform and complete success which can only be attained by their application in accordance with principles and facts established by scientific research.

The existence of even 0·25 per cent. of lead in copper renders it so rotten that it cannot be drawn into wire, and even so small a proportion as 0·1 per cent. of lead is said to unfit copper for wire-drawing. Hence the toughening and softening effects attained by the addition of a small quantity of lead to refined copper must be ascribable to some special action of the metal during the melting of the copper; and the fact that only *traces* of lead are discovered by the analysis of copper thus treated indicates that it operates in combining with, and removing, some impurity which is detrimental to the toughness and ductility of copper. That the

impurity thus extracted from the metal was oxygen appeared probable from the comparatively great affinity of lead for oxygen, and from the circumstance that the existence of oxygen in copper beyond some narrow limit was known to affect its quality prejudicially. The view that the beneficial effect of lead is due to a deoxidising action which it exerts, received further support from the beneficial influence of the metal in its employment in casting operations with copper and gun-metal, and Dr. Matthiessen's experiments afforded strong confirmation of its correctness.

A sample of pure copper, after fusion in contact with air, had a conductivity of only 87·25 ; 0·1 per cent. of lead was added to the metal, the two being fused together in a current of carbonic acid. By this treatment the conductivity was raised to 93, and the amount of lead remaining in the metal was too minute to be determined. Corresponding results were obtained with tin. The alloying of pure copper with 1·3 per cent. of tin reduced its conductivity to 50·4 ; but the melting together with 0·1 per cent. of tin, of the sample which had been fused in contact with air, raised its conductivity from 87·25 to 94·55—only traces of tin remaining in the copper.

The addition of small quantities of the readily oxidisable substance phosphorus (which also operates very prejudicially upon the conductivity of copper) has been found to perform the same function as these oxidisable metals.

The detrimental influence which the invariable impurity oxygen, in copper of commerce, exercises upon its electric conductivity, is, therefore, open to successful attack by the judicious addition of certain other impurities to the metal, which, while they may be most beneficially employed as chemical agents, might, if remaining alloyed with the copper, affect its conductivity as detrimentally as the impurity which they are the means of abstracting.

The analysis which Matthiessen made of a series of commercial coppers, the conductivity of which ranged from 14 to 92, and of six specimens of the core of the Gibraltar cable given to him by Dr. Siemens in 1860, the conductivity of which ranged from 67·4 to 90·7, afforded interesting confirmation of the results of his investigations upon the conductivity of pure copper, and contributed

importantly to indicate to the wire manufacturer the sources whence he should obtain, or the conditions as regards purity to be fulfilled in preparing, metal of a quality calculated to fulfil the conditions, in regard to conductivity for a particular *diameter* of conductor, laid down by the telegraph engineer.

The careful preliminary chemical investigation instituted by Matthiessen into the preparation of alloys applicable as means for measuring electrical resistances was also of important service to the telegraphist, by affording valuable aid to the Committee which was appointed by the British Association in 1861 to report upon the standards of electrical resistance, a Committee which included many of our most eminent members, and whose valuable investigations must be well known to all whom I have the honour of addressing.

The considerable advances which have been made of late years in the manufacture of iron and steel, consequent upon the diligent study of the theory of metallurgic processes and the improvement of these in accordance with chemical principles, have not been without influence upon telegraphy, as is demonstrated by the fact that the Government, not long since, raised the standard of quality, with respect to conductivity, of iron wire required for telegraph purposes, and that no difficulty has been experienced in obtaining supplies up to the new standard.

In the production of these the manufacturer is no longer dependent upon the comparatively very costly iron obtained in charcoal fineries, the desired result being attainable by judicious utilisation, by mixture and otherwise, of products obtained by the Bessemer process and others of importance recently elaborated.

While chemical science has unquestionably contributed to facilitate the selection of suitable materials for the *conductors* of cables, and to raise the quality of the available metals in regard to the essentials of efficient conductors for submarine and land cables, it has also been usefully applied in connection with the materials available as *dielectrics* in the manufacture of telegraph cables. It is, moreover, in this direction especially that we should look hopefully for important benefits to be derived in the *future* from the labours of the chemist.

One of the prominent subjects dealt with in considerable detail in the Report of the Submarine Telegraph Committee, to which I have already referred, is the character of the different insulating materials employed in the construction of cables; and the late Professor W. A. Miller instituted, at the desire of the Committee, an interesting chemical investigation into the causes of decay of gutta-percha and india-rubber. Professor Hofmann had already communicated to the Chemical Society, in 1860, the results of his inquiry, made for the Director-General of Telegraphs in India, into the nature and causes of the changes which gutta-percha was well known to undergo by exposure to air, and with special rapidity in tropical climates; he established the fact that they were due to oxidation of the gum, which becomes transformed, to a more or less considerable extent, into a brittle resinous substance. Similar results were obtained some years afterwards by Mr. Spiller in the examination of films of india-rubber which had been applied as a waterproofing material to felt. Dr. Miller examined more in detail into the changes which these two gums undergo, and arrived at the same conclusion as the other chemists, namely, that the alterations which the gums sustained, resulting in the gradual destruction of the characteristics which render them pre-eminently valuable as insulating materials, was entirely due to oxidation through atmospheric influence, and that such oxidation was accelerated by exposure of the material to light.

Dr. Miller also pointed out that an intermittent exposure to moisture, particularly if solar light has access, is rapidly destructive of gutta-percha, while, if kept continually immersed in water, it remains practically unchanged for indefinite periods. He showed that commercial gutta-percha contained already (before special exposure to oxidising influences) a proportion of the product of oxidation, or resinous matter, and he found as much as 15 per cent. of this substance in a sample of "good" commercial gutta-percha, taken from a piece of new cable furnished to him by Mr. Latimer Clark. There was also a very notable amount of water (2.5 per cent.) mechanically diffused through this sample, which appeared to him to have some influence upon its toughness and pliability.

The mechanical processes of preparation of gutta-percha have

doubtless undergone considerable improvements since the date of the Submarine Telegraph Committee's Report, but, judging by the results of some chemical examinations which I have recently had made of samples of new gutta-percha, several of which were received as being of high commercial quality, it does not appear that these have been productive of improvement in regard to the quality of the material, as indicated by its chemical composition. The highest quality of gutta-percha, in sheet, which I could obtain, was found to contain 12·7 per cent. of resinous matter and 5 per cent. of water; other samples, all of them new material, and ranking together in their price, which was but little lower than that of the particular specimen just spoken of, contained the following proportions of resinous matter and water:—

No.	Per-centage of resin.	Per-centage of water.	Ratio of resin to pure gutta-percha.
1	27·5	3	1 : 2·53
2	24·5	12	1 : 2·6
3	20·0	12	1 : 3·4
4	22·0	3	1 : 3·41
5	23·0	5	1 : 3·13

Two other somewhat lower-priced samples gave the following results:—

	Resin.	Water.	Ratio of resin to pure gutta-percha.
<i>a</i>	24·5	12	1 : 2·6
<i>b</i>	22·0	13	1 : 2·96

A pattern sample of sheet, which was of the same price as the above series, but had been at least one year in store, contained 20 per cent. of resin and 4 of water; a sample of gutta-percha rod supplied several years ago, and which has been continually exposed to air and light in my laboratory, contained 24 per cent. of resin and 2 per cent. of water.

It appears from these results, that, although a high-priced sample contained just below 13 per cent. of resin, it contained even more inclosed water than two (and as much as a third) somewhat lower-priced samples, while in several samples offered at about the same price by different well-known makers the resin ranged from 20 to 27.5 per cent., and the water from 3 to 12 per cent. The two samples, one year and several years old, have parallels among the series of new samples as regards both the resin and the water which they contain; there is consequently no evidence of their having suffered deterioration.

The high proportions of mechanically inclosed water existing in some samples of sheet gutta-percha of supposed high quality have certainly excited my surprise, but there can be no question that in the application of gutta-percha coatings to wire much greater pains will be taken to consolidate the material, and express inclosed water, than in the production of the sheet material. But that the amount of water inclosed by the coatings of insulated wires is somewhat considerable, even in recently manufactured articles, is shown by the fact that in two samples of covered wire made by the same manufacturers, one in September the other in November last, the former contained 1.86 per cent., the latter 3.97 per cent. of water (the sample of newly-covered wire examined by Miller contained 2.5 per cent.). A sample of gutta-percha-covered wire which has been kept by me in a tank of water for at least *ten* years, having been only exposed to air for brief periods at long intervals, and having been in the water undisturbed for about eighteen months previous to its examination, contained 3.07 per cent. of water, or less than one of the samples of new wire which had not been kept in water.

There is little doubt that the mechanical processes of mastication, &c., to which gutta-percha is subjected (and upon the thorough application of which the separation of a particular kind of impurity and the production of a mechanically homogeneous material depends), favour its oxidation, so that the proportion of resin in the finished substance, and the consequent admixture of the gum with a product detrimental to certain of its most valuable qualities as a dielectric for telegraphic purposes, may be to no unimportant

extent dependent upon the degree of completeness to which the mechanical treatment for the separation of their impurities has been accomplished. The results of examination of specimens of *old gutta-percha* of high quality would appear to show that, provided the material has been reduced to a comparatively compact condition, of which the proportion of inclosed water may serve as some indication, the oxidation of the gum by exposure to air and light proceeds but slowly.

The effect of mastication in promoting the changes by oxidation of *india-rubber* (doubtless in consequence of a considerable increase in the porosity of the substance, and of the distribution of inclosed air throughout the mass) was also pointed out by Miller, and further experience has established the similarity of the gums in this respect.

The application of the vulcanising process to the *india-rubber* coatings or wires was hailed as a very important advance in the preparation of telegraph wires or cables, but, unfortunately, although the action of the process of vulcanisation has been repeatedly made the study of chemists, it remains but very imperfectly understood, and, as a natural consequence, the various processes of treatment of *india-rubber* with sulphur or sulphur-compounds continues to be highly uncertain in regard to the character and permanence of the results they furnish, these being seriously affected by some slight variations in the conditions attending the preparation and treatment of the *india-rubber*, apparently still beyond the control of the manufacturer. The most important objection, of a chemical nature, to this application of the vulcanising process, which was encountered in the earliest days of its history, namely, the injury sustained by the copper conductor consequent upon the chemical action of the sulphur contained in the dielectric upon the metal, was set aside by the manufacturer availing himself of the chemical fact that tin resists the action of the sulphur under certain conditions which are favourable to the union of that substance with copper, so that the conductor could be efficiently protected by applying the simple process of tinning. But the tendency to an alteration, either in chemical character or mechanical structure, or both, exhibited, though to a very uncertain degree, by vulcanised *india-rubber* even, sometimes, when it is kept submerged in

water, has developed serious elements of uncertainty—well known to my audience—in cables prepared by vulcanising processes. The experience in the durability of cables for military-telegraphic and submarine-mining operations, which I have acquired during the last few years, enables me to give a few interesting and perhaps not unimportant illustrations of the imperfect nature of existing knowledge regarding the chemical and other conditions to be fulfilled in the application of vulcanising processes to the preparation of telegraph cables.

A considerable number of half-mile lengths of vulcanised telegraph cable (covered with tape) was obtained from different makers for military field-telegraph service, and for firing broadsides on board ship. The cable was apparently of excellent quality when delivered, but portions issued for service, and therefore subjected from time to time to the effects of exposure to weather, and in a few instances to occasional immersion in sea-water, were found, within *three years*, and within *eighteen months* of the date of their purchase, to have undergone very serious deterioration; indeed, in some instances they had become absolutely unserviceable, the insulation resistances of the half-mile lengths having in several instances fallen below 3,000 ohms. A careful examination of some of these cables showed that, although here and there they had sustained injury from abrasions or punctures (india-rubber-covered cables being peculiarly liable to the latter kind of injury), their defective condition was generally due to an alteration sustained by the dielectric in parts, whereby the material had become quite porous, so that even the variations in the hygroscopic condition of the atmosphere on board ship, where the wires were fixed between decks, caused decided differences in the results obtained with a particular battery-power. The continuous passage of a current for a short time through portions of such wires, while submerged, restored their efficiency by the sealing of the pores in the insulation by electrolysed gas, as was demonstrated by reversing the current, which established the original leakage. This alteration in the dielectric was not uniformly distributed over a length of cable; the porosity was in some instances found to extend along a few feet only, the adjacent portions being in a very good condition.

An inspection of a large number of these field-telegraph cables, which had remained untouched in store since their delivery, showed that many of these had also suffered deterioration, but that the alteration they had sustained varied very greatly in extent, the insulation resistance of the half-mile lengths having fallen in some instances as low as 6,000 ohms. These cables were stored together, in a dry building, in half-mile coils, inclosed in canvas-wrappings, and therefore protected from light.

Many of the armoured cables, with single and multiple cores (the dielectric being vulcanised throughout), which have been provided for submarine-mining service, and which have been kept immersed in water from the time of their delivery, during the early part of 1872, were found when tested for insulation resistance, about eighteen months after their supply, to have suffered deterioration generally, and in some instances to a very considerable extent. The insulation resistance of the single armoured cables had fallen from 13,000 megohms, and upwards, to from 100 to 450 megohms, but the greatest change was exhibited in some of the multiple (seven) core cables. Most of these contained one or more cores which had fallen in insulation resistance very much more than those inclosed in the same cable, and a re-examination of the cables after the lapse of another year's immersion showed that this comparatively very great deterioration of certain cores continued rapidly. Thus, while in one cable five cores gave insulation resistances ranging from 68 to 1140 megohms, two cores, side by side with them, gave only 9.9 and 1.5 megohms; the deterioration of these cores had moreover progressed rapidly, while that of the others appeared to have ceased, at any rate for a time. Other multiple cables exhibited a similarly remarkable want of uniformity in the condition of the insulation of the cores which they inclosed; the special examination of these indicated that the great fall in insulation resistance of certain cores was most probably due to a local alteration of the dielectric similar to that observed in the field telegraph cables of like manufacture, and furnished additional proof of the uncertainty attending the application of the vulcanising process to the attainment of permanently efficient insulation.

The idea suggested itself that the employment of tar, in con-

junction with the hemp used in the manufacture of these cables, might have operated prejudicially upon the insulating property of the vulcanised india-rubber, but the impregnating material used in all these cables was Swedish pitch, which, so far as I can learn, has never been observed to exert any detrimental action; moreover the very different behaviour of the cores inclosed even in one and the same multiple cable was conclusive evidence against the possibility of the deterioration emanating from that direction.

The dielectric of the cables just referred to consisted, as already stated, of india-rubber vulcanised *throughout*; but experience scarcely less conflicting, and perhaps even more interesting in its nature, has been acquired with cables purchased for submarine-mining service, of which the dielectric was prepared according to Hooper's system. This, as I need scarcely remind my audience, consists in maintaining the inner portion of the india-rubber, by which the conductor is surrounded, in an unvulcanised condition (with the view of guarding against the possibility of sulphur having access to the copper), through the agency of a so-called *separating* layer, containing a preparation of a metal which has the power of arresting the passage of sulphur beyond it, during, and subsequent to, the application of the vulcanising process to the external portion of the dielectric. The experience acquired with a field-telegraph cable, made according to this system, was most favourable; it was taken into use in 1867, and the efficiency of its insulation has remained practically unimpaired, except where it had sustained mechanical injuries. The inner, unvulcanised, portion of the india-rubber of this cable still exhibits no sign of change at any part. The same indication of permanence has been exhibited, so far, by a number of armoured cables, supplied for submarine mining service, the dielectric of which was manufactured according to Hooper's system, and which have been stored *in air*. The insulation-resistance has certainly fallen considerably, in most instances, in these cables, but the unvulcanised portion of the dielectric has exhibited no signs of alteration, even at the extremities to which air has, of course, had access. But the cables of quite similar make, which were kept stored *in water*, and a number of which were also stored *dry*, side by side with those just referred

to, have exhibited a different behaviour. The inner or unvulcanised portion of the india-rubber of the ends of all the cables which were stored in water immediately upon delivery, had, within a year of their receipt, become more or less viscous and exuded from the extremities, exhibiting, in fact, the change already spoken of, which has been considered to be due solely to oxidation. This change has been found to be confined in *these* cables to the portions (only a few feet in length) which have been always kept out of water for testing purposes, the altered portions of the india-rubber being found to terminate sharply at the points where the immersion of the cables commenced. This appeared conclusive as to the change being the result of oxidation; at the same time it appeared curious that oxygen should penetrate to the interior of the armoured cable from the extremity, even to a distance of several feet.

The same exudation of the viscous product of change of the unvulcanised india-rubber having been observed at the extremities of a number of the armoured cables, containing Hooper's core, which were stored *in air*, a special examination was instituted of two of these, and it was found that the change in question was not limited to the extremities, but extended at any rate to a great distance along the cables (which were coiled on drums). Three lengths of fifty yards each were cut off from one of these cables, and the inner extremities of all of these exhibited the unvulcanised rubber in the same viscous state; at the extremity of another 200 yards of this cable the same change existed, though it was not quite so complete as at the other parts where the cable was cut. It is obviously impossible that atmospheric oxygen could have penetrated from the extremities of these cables to this great distance; indeed, the viscous nature of the product of change of the india-rubber would appear altogether to preclude its penetration even to very short distances from those directions. If, therefore, this alteration of the india-rubber is only brought about by oxidation, the oxygen must evidently find access to the interior of the dielectric *through the substance* of the cable; and that such a penetration is not only possible but certain is demonstrated by some of the results obtained by the eminent chemist Graham, in *his remarkable researches* on "the absorption and dialytic separa-

tion of gases by colloid septa." Graham found that solid india-rubber (punched out of a block) absorbed oxygen to an extent which showed this gas to be twice as soluble in rubber as in water at the ordinary temperature; the comparatively greater porosity of vulcanised india-rubber would additionally favour the absorption of oxygen, and it is evident that by this absorbent power oxygen must be gradually conveyed to the interior of the india-rubber coating of an insulated wire. The oxidation of the unvulcanised india-rubber being once established, the tendency to the absorption of oxygen by the external vulcanised india-rubber, and to its passage through the latter, must be promoted by the increased tendency to chemical change of, and the continual assimilation of oxygen by, the inner portion, which will operate in some measure like the application of a vacuum, by which Graham caused air very rich in oxygen to filter through a stout vulcanised india-rubber tube. The alteration of the unvulcanised portion of the dielectric in a cable containing Hooper's core, which is kept exposed to air, is therefore easy of explanation, and if such a cable be exposed to air, even for no very lengthened period, *before* its submersion, the change of the india-rubber may have already proceeded to a considerable extent. But, *how* is it that cables, of which the dielectric has been prepared according to one and the same system, applied, presumably, with as much uniformity as possible, and which have been stored in air, side by side, under precisely the same conditions, behave so differently; the unvulcanised portion of the india-rubber exhibiting not the slightest symptom of change, even at the extremities, in some cases, while in others it is more or less converted into the viscous product throughout the cable?

Messrs. Hooper furnish an explanation, which, from their careful study of the matter, merits full consideration. They depart somewhat from the principle laid down by Mr. Hooper as the basis of his process, namely, the *absolute* protection of the inner portion of the dielectric from access of sulphur, and consider that the impregnation of it by a minute proportion of sulphur, when the vulcanising process is applied, is essential to its protection from change, so that the alteration in some instances of the interior of the dielectric

would, according to this, be ascribable to an accidental failure in the necessary transmission to it of this minute proportion of sulphur. How far this explanation has been verified I cannot say, but at any rate this appears to be a problem which, as in the case of the capricious behaviour, in regard to deterioration, of *completely* vulcanised dielectrics, the application of chemical science should be expected to solve.

It should be stated that the conversion of the india-rubber into the viscous product does not appear, so far as any experimental and other inquiries extend, to be detrimental to the insulation of cables in which it has recently occurred, but it remains to be ascertained by experience whether the transmission of sulphur to the conductor, which Mr. Hooper made his fundamental object to guard against, will not be favoured by the conversion of the interposed pure india-rubber into the semi-fluid product, which may perhaps in time also exert a solvent or softening action upon the outer vulcanised coating, and thus act destructively upon the insulation. Even if the insulating power is not reduced below working requirements, the transformation of the solid material immediately surrounding the conductor into a semi-fluid substance cannot but detrimentally affect the structural strength of the cable.

I feel I should apologise for the tedious length of my observations on insulating materials, for I know they were not needed to impress you with the importance of the application of chemical research to a more complete study of the causes of the defects in the dielectrics at present in use, and to the production of insulating preparations, suitable for cable-covering, which shall possess the chemical as well as physical characters essential to permanence under all climatic and other influences to which land and submarine cables may be subject. The efforts which have been made from time to time to produce new insulators, or to improve the existing ones, may be said to have served, until lately, chiefly to clear the ground for future experiment; but there is one direction in which, after repeated unsuccessful efforts by different experimenters (among whom I must include myself), important success appears to have been achieved.

One of the most absolutely permanent materials, of organic origin,

though occurring in the mineral kingdom, is the solid product of the distillation of peat and of certain descriptions of coal or bituminous minerals; which also exists in many varieties of petroleum or mineral oils, and is known as *paraffin*, or as *fossil-wax*, *Hatchitin* and *Ozokerit*, in its native forms. This substance, which, during the last thirty years, has passed from the obscure position of a chemical curiosity to the foremost rank among important chemical products, thanks to the practical development of the results of pure chemical research, is possessed of high insulating power, and has consequently received some useful applications in connection with telegraphy; among others, as a ready means of producing good joints; but it is deficient in certain characteristics indispensable in a dielectric for covering wires, and attempts to apply it as such in various ways have led to no satisfactory result. It was noticed several years ago by myself that india-rubber and gutta-percha could be readily dissolved in melted paraffin, and preparations were thus obtained which appeared promising not only as cheap waterproofing materials but also as insulators, a promise which, with regard to the latter application, was not verified. Mr. Mackintosh applied the masticating process to the incorporation of the gums with paraffin, but it does not appear that his efforts thus to obtain serviceable insulating preparations stood the test of actual practice. A few years afterwards, when the native paraffin known as ozokerit had acquired importance in candle-manufacture, Dr. Matthiessen experimented with that material, and, more especially, with a black residue of high melting point, furnished by the partial distillation of ozokerit. By heating them together with gutta-percha and india-rubber he obtained preparations of high insulating power, and considerably superior in point of hardness to those produced by Mr. Mackintosh and myself; unfortunately, however, they speedily became brittle and useless for telegraphic purposes. But in 1875 Mr. F. Field, F.R.S., an eminent chemist, working in conjunction with Mr. Talling, a well-known mineralogist, succeeded in producing mixtures of the black ozokerit-product with india-rubber which appeared quite free from the defects exhibited by Dr. Matthiessen's preparations. This they accomplished either through the agency of a solvent, or, preferably, by masticating the substances together

at the lowest possible temperature requisite to reduce them to a plastic condition. The mixtures of india-rubber with very large proportions (even 90 per cent.) of the ozokerit, when obtained in this way, are possessed to a remarkable extent of the physical characteristic of india-rubber itself, though they are, of course, much softer and more plastic. They are not rendered brittle by long-continued exposure to cold, and appear to be improved by time in regard to hardness combined with toughness. The results of tests, as regards insulation and inductive capacity, to which wire-coatings of this preparation have been submitted, compare very favourably with those given by india-rubber and gutta-percha, and there appear good grounds for entertaining the belief that these preparations will prove very valuable for telegraphic purposes, more especially as india-rubber is very likely to be effectually protected from change by its intimate incorporation with the thoroughly stable substance, paraffin.

I have been led into such discursive discussion of the connection of chemical science with two subjects of great interest to the telegraph engineer, that I must content myself with simply referring to one or two other directions in which chemical knowledge cannot fail to benefit those engaged in the profession. I need scarcely point out that the improvement and the management of batteries, subjects of primary importance to the telegraph engineer, cannot be properly grappled with in the absence of sound chemical knowledge, even though much mechanical detail is involved in them. The members of this Society have had recently so excellent an opportunity of becoming fully impressed with the value of the application of chemical science in these directions, by a perusal of Mr. Sivewright's valuable paper "On Batteries and their employment in Telegraphy," and of the other papers and the instructive discussion which it elicited, that it will suffice for me simply to recall the importance of this subject to their recollection. Other matters of interest and importance upon which communications have been made to the Society, resulting in instructive discussions (*e.g.* the decay and preservation of telegraph-poles, the preservation of fibrous materials used in the construction of submarine cables, *the production of joints*, the protection of cables against deposition

of vegetable or animal growth), have also afforded illustration of the benefits which the telegraph engineer may derive from the fruits of applied chemistry.

Lastly, I will venture still to detain you by a trifling illustration of the unexpected manner in which problems may occur, in the course of the practical electrician's labours, to the solution of which it is indispensable that chemical knowledge should be brought to bear.

In a paper contributed to the Society by one of its more prominent members, Lieutenant-Colonel Stotherd, R.E., on electric fuzes, that officer pointed out that certain defects in point of permanence, and certain difficulties connected with the electrical testing, of the "phosphide" high-tension fuze known by my name, had led me to construct another form of high-tension fuze specially for submarine mining service. In this, the conducting and igniting composition or bridge which connects the poles consists of a very intimate mixture of graphite and mercuric-fulminate, two substances concerning whose freedom from liability to oxidation by atmospheric influence, and otherwise permanent characters, no doubt could be entertained. The poles of this fuze like those of the older one] consisted of two fine copper wires, arranged parallel, and embedded at a distance of 0.05 inch apart in an insulating column, which, in the new fuze, consists of a mixture of Portland cement with sufficient sulphur to allow of its being melted and cast in a mould, producing a very rigid support, upon which the priming composition can be consolidated over the slightly projecting terminals of the copper wires or poles by the application of considerable pressure, the electrical resistance of the fuze being regulated by the degree of compression of the composition. This cast column or insulating support of cement was adopted in place of the gutta-percha used in the old fuze, because the want of rigidity in the latter material did not permit of the attainment of uniform and permanent compression of the priming composition. This so-called "submarine fuze" having furnished very satisfactory results, a number were supplied to different military stations for submarine mining service, but, after a considerable time had elapsed, many of them were found to have fallen very greatly in

resistance ; thus, the average resistance of the fuzes being 15,000 Ohms, many were found to have only a resistance of 300 or 400 Ohms, and one or two had fallen even below 50 Ohms. The careful dissection and examination of these fuzes afforded at first no clue whatever to the cause of this change. The graphite-fulminate mixture appeared unaltered in compactness and was unchanged in composition ; and, on being removed from the altered fuzes and applied as priming material in new fuzes, the resistances of these was the same as if new composition had been employed. Mr. E. O. Brown, a member of this Society who has done good work in applied electricity, was deputed by me to unravel this mystery, and soon fathomed it. An examination of the interior of the small pillars of cement, which appeared from the exterior perfectly solid throughout, revealed the existence in many of them of very minute hair-line cracks, or fissures, extending sometimes right across the space between the inclosed small copper wires, and evidently caused by unequal contraction of the wires and the cement when the latter had been cast round the former. These minute fissures would of themselves not have affected the electrical character of the fuzes, but the surfaces of many of them were observed to be dark-coloured, and this colouration proved to be due to sulphide of copper. The penetration of air, and with it the ever-concomitant moisture, to the interior of these little columns, established, in course of time, chemical action between the sulphur in the cement, the copper surfaces, and the atmospheric oxygen ; the resulting sulphate of copper was slowly conveyed by the moisture and the capillary action of the minute cracks along these on either side, becoming afterwards reduced by the sulphur in the cement to sulphide, with which the fissures became coated until it formed one or more complete bridges between the copper-poles. Thus the high-resistance bridge, or the fuze proper, was in course of time completely cut out of circuit by the formation of one or more very perfect though minute Statham fuzes, of comparatively high conducting power, in the head of the fuze itself. Chemical knowledge, having been instrumental in discovering this unsuspected source of failure, at once provided the remedy ; fine wires of platinum, upon which the sulphur, aided by air and

moisture, has no action, were substituted for those of copper, and the permanence of the fuze was secured.

The intimate connection of chemistry with applied electricity might be exemplified by many other illustrations taken from the experience of those who have devoted themselves to the development of the science and practice of submarine mining, whose labours are, in many respects, akin to those of the telegraph engineer, and who (so far as England is concerned) have become affiliated with the members of that profession through the medium of this Society.

The undue length which my address has reached forbids my entering upon any discussion of a subject which, however interesting to myself and to some members of the Society, only borders on the sphere of action of the telegraph engineer, although there can, I think, be no question that the elaborators of torpedo-service in England have already, by some of the results of their studies and of their very varied though limited experience, repaid in a measure the invaluable aid derived by them from the knowledge and more extended experience of the telegraph engineer.

The interest which I naturally take in that branch of applied electricity which is destined to play a most important part in any future war, and to the elaboration of which—as an indispensable auxiliary to our national defences—I have, during the last twelve years, devoted my best energies, in cordial co-operation with the Royal Navy and the Royal Engineers, tempted me much to select it as the theme of my address this evening. I venture to hope that in resisting this temptation in favour of the cause which I have pleaded, namely, the intimate connection of chemical science with the profession of the telegraph engineer, and the importance of its cultivation by those who devote themselves to the advancement of that profession, I have, at any rate, evinced my earnest desire to perform some little service in testimony of my appreciation of the high honour which has been conferred upon me by this its representative Society.

Mr. W. H. PREECE: It is my special pleasure and duty to-night to propose that a vote of thanks be accorded to Professor Abel for the able, interesting, and clear address he has just delivered to us,

and also that that address shall be printed and distributed amongst the members of this Society. In the commencement of his remarks the President questioned the prudence and wisdom of the managers of the Society in selecting him to represent us as our president; but if his qualifications as a practical chemist, as a scientific electrician, and as an experimental philosopher were not already well known to you, it was only sufficient for you to have heard his address to-night to know that we have at our head one of the ablest men of the day. (Hear, hear). He spoke of his address as being a discursive discussion, but I think we must all acknowledge that it was a highly practical, scientific, and philosophical paper. If it had one defect it is not that which he so modestly calls its undue length, but its shortness. We could, I am sure, have borne for another half-hour, with ease and comfort, such excellent advice as that which fell from his lips. He spoke of a most important subject to electricians of the present day, that is, the behaviour of dielectrics; and I am sure he has succeeded in supplying all those who are engaged in practical telegraphy with thoughts which must tend to the discovery of the means of overcoming those defects and peculiarities which have to a certain extent up to this moment retarded the introduction of underground wires in our telegraph system. The storms and excessive rains of the present winter have called attention very vividly to the necessity of endeavouring to replace our exposed lines by the safer and more secure mode of construction—viz., underground; and I am sure many of us who are permitted to engage in these matters will receive great help from the practical remarks we have heard to-night from Professor Abel. I was in hopes we should have heard a little more about torpedo warfare, but he has led us to venture to hope that we may yet have a paper, if not from his own hands, at least prepared under his guidance, which will enable the whole subject of torpedo warfare to be discussed in this room. If England is to maintain her position in the van of naval powers it is by placing herself in advance of everybody in improving torpedo warfare; and it is by the application of talents such as those of Professor Abel—by such skill and experimental power as he has developed, that we shall *succeed*, as in the case of guns and in the case of ships, &c., in

maintaining ourselves in the front rank in the matter of torpedoes as well as in everything else.

Major BATEMAN CHAMPAIN: I have been asked to second the vote of thanks to Professor Abel, which has just been proposed by Mr. Preece. In doing so I will not detain you one minute. I wish merely to echo the remarks of my predecessor, and to say, I think we are willing to accept everything we have heard this evening from our new President, except that with which he commenced his address. We shall all agree with him that his predecessors have been men of eminent capacity, but I feel sure you will agree with me that our standard of excellence will not be lowered by our having elected Professor Abel as our President. I beg, therefore, to second the proposition that we give him a vote of thanks for his able address, and that it be printed and entered in our records.

The motion was carried by acclamation.

The PRESIDENT: I have to express to you, gentlemen, my satisfaction at the favourable manner in which you have received the remarks I have brought before you. I wish I could hope to realise all that the proposer and seconder of the vote of thanks have said as likely to accrue during my term of presidency. I can only say, I trust we shall have many interesting communications and discussions which will demonstrate what I have ventured to direct your attention to this evening, viz., the intimate connection between applied science and telegraph engineering. Mr. Preece has made a statement which I confess has taken me a little by surprise. I was not aware that I had in any way foreshadowed a paper on submarine mining, either in my address or in any incautious remark I may have made during the brief period of my holding this chair. All I can say is, should the subject come before us, I am sure—though only a small section of the members may be directly interested in it—many matters of interest to telegraph engineers generally will be found to be embraced in it, and many points which may be discussed here with great advantage to those who are occupied with this particular branch of applied electricity. Gentlemen, I thank you most cordially.

The following Associates were transferred to the class of Members :—

Mr. Andrew Bell.
 Mr. John Gott.
 Mr. Walter Judd.
 Mr. William Mayes.
 Mr. H. C. Saunders.

The following candidates were balloted for and duly elected :—

FOREIGN MEMBERS :

Edward E. Blavier.
 Charles Bontemps.
 Fedeli Carderelli.
 Joseph Lagarde.
 Count du Moncel.
 Jules Raymond.

MEMBERS :

Robert Punshon.
 Lieut. Rogers, R.N.
 T. Skinner.
 Julius Terp.
 W. Wiese.

ASSOCIATES :

Edward Almack.
 Samuel Bidder.
 James Brown.
 George Clapperton.
 Charles Field.
 John Fraser.
 W. J. Fraser.
 Henry Goodman.
 T. Gothorpe.
 T. J. Wilson.

The meeting then adjourned.

The Fifty-third Ordinary General Meeting was held on Wednesday, the 14th day of February, 1877, Professor ABEL, F.R.S., President, in the Chair.

The PRESIDENT: I have to announce that Dr. Werner Siemens has been appointed Local Honorary Secretary of this Society for Germany, and also that Major Bolton has presented to the Society a portrait of Mr. Latimer Clark, painted by Miss Thompson. It is a most successful portrait, as those members who attended the *Conversazione* will remember, as it was exhibited there; and I am quite sure the members of the Society will confirm the action taken by the Council in a resolution which they have passed, viz. That a cordial vote of thanks be given to Major Bolton for this handsome donation to the Society.

The vote of thanks was carried by acclamation.

The PRESIDENT again rose and said: I think Mr. Preece will pursue a course which will be agreeable to the members. Instead of simply reading the paper, which has been printed for the use of the members, he will give us a summary of his paper; and, in addition to the diagrams which we see before us, he will give us some experimental illustrations.

ON SHUNTS, AND THEIR APPLICATION TO ELECTROMETRIC AND TELEGRAPHIC PURPOSES.

By WILLIAM HENRY PREECE, M.I.C.E., Vice-President.

A.—*Object of Paper.*

Shunts have become such an essential feature of practical telegraphy, and have been so little considered in telegraphic literature, that I purpose in the following paper to narrate and explain, as far as my experience will allow me, their nature, employment, and utility. I do not anticipate suggesting anything that is new, but I hope to bring together in a connected form much that is now

scattered and only partially known, but which is of value to the profession generally. Owing to the disagreement that exists amongst electricians as to the various technical terms in use, I think it right, first of all, to explain the meaning of such terms as I shall use, so that there shall be no mistake as between me and my hearers. It is a misfortune in the present condition of the science of electricity that such a necessity should arise, but while it is scarcely possible to find two books, or even two telegraph engineers, to agree in applying the same terms to the same electrical functions or properties, I wish to establish at once a clear understanding with those I address as to the meaning of the technical words I use.

B.—*Terms used.*

1. *Potential* is a term applied to that condition of matter which determines the motion of electricity from one point to another. What potential is, or how it is measured, does not fall within the scope of this paper. It is here used simply to express that function of electricity which determines its flow, in the same sense that *temperature* determines the flow of heat, and *pressure* that of gases and fluids.

2. Wherever we have two points at different potentials separated from each other by a conductor or conductors we have the simple conditions required for the presence of a *current of electricity*.

3. Whatever produces this difference of potential is called a *source of electricity*, and the difference of potential itself is called *electromotive force*.

4. The ease or difficulty with which the conductor favours or obstructs the flow of electricity is called its *resistance*, and Ohm has established the simple law that the magnitude or *strength* of every current varies directly as the electromotive force producing it, and inversely as the resistance obstructing it. This is expressed by the well-known formula,

$$C = \frac{E}{R} \text{ or } E = C R.$$

5. *Conductivity* is simply the reciprocal of resistance.

6. *The Current* is a term applied to the whole flow of electricity from the point of higher potential to that of lower potential in the source, whatever that source may be, and the position of these two points gives the *direction* of the current.

7. The direction of the current with respect to any given point is indicated by the terms *positive* and *negative*—the current which flows *from* the copper pole of an ordinary battery being positive at that place.

8. Currents differ from each other in strength, direction, and *duration* only.

9. Currents which follow from, or are brought into existence by the influence of, other currents are called *induced currents*. The inducing current is called the *primary*, and the induced current the *secondary*.

10. *The Circuit* is the entire path or paths by which the current flows. The circuit may consist of one simple metallic wire; or it may be formed by such a wire and the earth; the current may flow through several wires with or without the earth by accident or design; or it may leak partially or wholly through several supports to and through the earth.

11. That portion of the current which continues to flow through the special path provided for it is called the *main current*, while the path itself is called the *main circuit*. The branches which abstract as it were minor currents from the main current are called *derived circuits*, and the currents in them *derived currents*.

12. A *Shunt* is a technical term applied to what is thus more scientifically known as a derived circuit, but it is strictly applied to a derived circuit when that circuit is designedly adapted to apparatus for the practical purpose either of measurement or of working.

13. When wires, forming a portion of a circuit, are joined up so that the main current is split or divided amongst several branches they are said to be joined up in *multiple arc*, and when these branches are reduced to *two* the combination is said to be a *duplicate arc*, of which one branch may form the main circuit and the other branch the shunt. It may and often does arise that

each branch is equally a portion of the main circuit, and then they are merely called the *branches of the circuit*.

C.—*Law of Shunts.*

1. We will first of all examine the relations that exist between the resistances and currents of the branches of a multiple arc and of the main circuit.

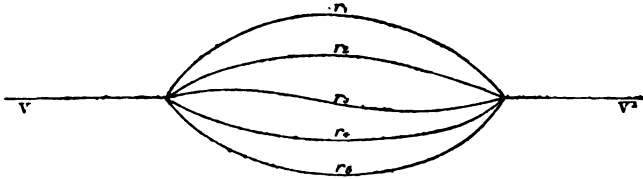

Fig. 1.

Let there be several derived circuits meeting at the points V and V¹ (fig. 1), forming a multiple arc.

Let the resistances of these branches be $r_1 r_2 r_3 \dots r_x$ respectively. Let V be the potential of one point and V¹ that of the other.

Let the derived currents in each branch be $c_1 c_2 c_3 \dots c_x$.

Let the current be C and the combined resistance of the multiple arc R.

Then, since $V - V^1$ or the electromotive force (B 3) is the same for all the branches, by Ohm's law,

$$c_1 r_1 = c_2 r_2 = c_3 r_3 = \dots = c_x r_x = C R \dots (1),$$

whence
$$c_1 = C \frac{R}{r_1}, c_2 = C \frac{R}{r_2}, \dots c_x = C \frac{R}{r_x},$$

but
$$C = c_1 + c_2 + c_3 + \dots + c_x$$

for the current is neither increased nor diminished in the multiple arc.

Therefore, substituting for $c_1 c_2$, &c. their values from above,

$$C = C \frac{R}{r_1} + C \frac{R}{r_2} + C \frac{R}{r_3} + \dots + C \frac{R}{r_x},$$

and dividing by C R

$$\frac{1}{R} = \frac{1}{r_1} + \frac{1}{r_2} + \frac{1}{r_3} + \dots + \frac{1}{r_x} \dots (2);$$

or, since the conductivity of a circuit is the reciprocal of its resist-

ance (B 5); the conductivity of a multiple arc is the sum of the conductivities of its various branches.

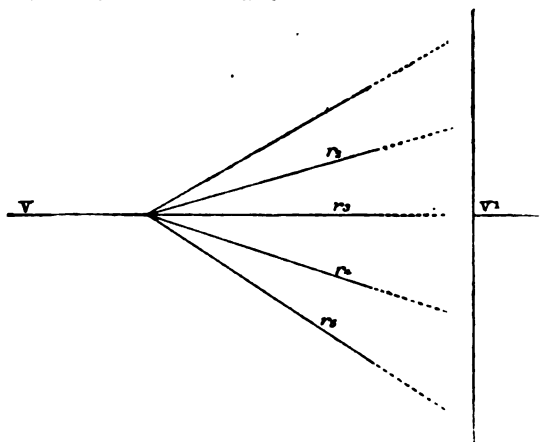

Fig. 2.

It is evident that fig. 2 is merely a case of fig. 1, where each branch terminates in the earth.

2. Prob. 1.—To find the combined resistance of a duplicate arc.

Since from (2)

$$\frac{1}{R} = \frac{1}{r_1} + \frac{1}{r_2},$$

$$\therefore R = \frac{r_1 r_2}{r_1 + r_2} \dots \dots \dots (3).$$

3. Prob. 2.—To find the relative strengths of the currents in the different branches of a duplicate arc.

Since from (1)

$$c_1 r_1 = c_2 r_2$$

$$\frac{c_1}{c_2} = \frac{r_2}{r_1} \dots \dots \dots (4),$$

or the derived currents of the two branches of a multiple arc are to each other *inversely* as their resistances.

4. Prob. 3.—To find the relative resistance of the branches of a duplicate arc to give any required ratio between the derived currents and the main current.

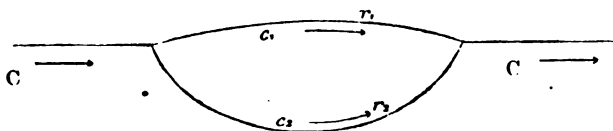

Fig. 3.

Since in fig. 3 $C = c_1 + c_2$ and $\frac{c_1}{c_2} = \frac{r_2}{r_1}$,

then by proportion $\frac{c_1}{c_1 + c_2} = \frac{r_2}{r_1 + r_2}$,

and by substitution $\frac{c_1}{C} = \frac{r_2}{r_1 + r_2}$,

whence $c_1 = C \frac{r_2}{r_1 + r_2}$ } (5).
 similarly $c_2 = C \frac{r_1}{r_1 + r_2}$ }

Let the current in the main circuit be the n^{th} part of the whole current, or

$$c_1 = \frac{C}{n},$$

then, substituting this value in (5),

$$\frac{1}{n} = \frac{r_2}{r_1 + r_2},$$

and $\therefore r_2 = \frac{r_1}{n - 1}$ (6).

The derived currents in each branch are—

$$c_1 = \frac{C}{n},$$

$$c_2 = C \left(\frac{n - 1}{n} \right).$$

and $\therefore \frac{c_1}{c_2} = \frac{1}{n - 1}$

Thus, to reduce the current in r_1 to any fraction $\left(\frac{1}{n}\right)^{\text{th}}$ of the current C, it is only necessary to make the resistance of the branch r_2 , $\left(\frac{1}{n - 1}\right)^{\text{th}}$ that of r_1 .

5. But this assumes that the current (C) remains constant after the application of the branch r_2 . It is, however, evident that if we reduce the resistance r_1 to $\frac{r_1 r_2}{r_1 + r_2}$ the main current will be

increased, for in the first instance

$$C = \frac{E}{R + r_1},$$

and in the second instance

$$C_1 = \frac{E}{R + \frac{r_1 r_2}{r_1 + r_2}}.$$

To maintain C constant or to make $C_1 = C$, we must insert in the main circuit a certain resistance x , so that

$$x + R + \frac{r_1 r_2}{r_1 + r_2} = R + r_1,$$

whence

$$x = \frac{r_1^2}{r_1 + r_2},$$

or substituting its value for r_2 in (5) then $x = r_1 \left(\frac{n-1}{n} \right)$. . . (7).

Hence, if it be desired to reduce the current in r_1 to any fraction of the whole current we can do so by making the resistance of r_2 $\left(\frac{1}{n-1} \right)^{th}$ of that of r_1 provided that we insert in the main circuit a

resistance $x = r_1 \left(\frac{n-1}{n} \right)$.

It is evident that this correction may be neglected when r_1 is very small compared with R .

D.—Use of Shunts for Measuring Purposes.

1. Let us now consider the practical uses in telegraphy to which shunts have been applied, and first as regards their *electrometric purposes*.

2. Wheatstone in his classical paper of 1843,* which formed the subject of the Bakerian lecture, and which was published in the Philosophical Transactions of that year, proposed the use of a derived circuit equal in resistance to the galvanometer to ascertain what

* "An Account of several New Instruments and Processes for determining the Constants of a Voltaic circuit."—*Phil. Trans.* Part II. 1843.

degree of the galvanometric scale indicated *half* the strength of the current corresponding to any given degree.

He also pointed out how the same galvanometer, however delicate, may be employed to measure currents of different strengths, without introducing any inconvenient resistance in the main circuit, by means of derived circuits, provided the compensation resistance given by equation (7) be introduced in the main circuit to maintain the main current of the same strength.

3. Petrina of Linz * had in the previous year (1842) proposed a shunt of mercury, into which the ends of the galvanometer wires were inserted at various distances from each other, to calibrate his instrument.

Melloni † also adopted a somewhat similar plan in calibrating his galvanometer for his celebrated thermo-electric and radiant heat researches. He showed how the insertion of a shunt of about one-fourth the resistance of the galvanometer enabled him to indicate equal increments of current strength by the ordinary graduation of his galvanometer. It is well-known that up to about 15° any ordinary galvanometer represents by its angular deviation fairly accurately the proportionate increased strength of current, but that beyond this deflection the proportion ceases. The sine and tangent galvanometers enable us to arrive at the increments of current by using those functions of the angles of deflection, but an unaided ordinary galvanometer is useless for that purpose, unless supplemented by some such device as that used by Melloni.

Since from equation (5)

$$c_1 = C \frac{r_2}{r_1 + r_2},$$

it follows that if we make r_1 and r_2 constant, and simply vary the currents, the reduced current (c_1) will always bear the same proportion to the prime current (C) whatever the strength of the latter may be. Thus, since each degree of the scale up to 15° indicates equal increments of current strength, it is only necessary to apply a shunt

* Phil. Trans. Part II. 1843. Wheatstone's Paper.

† Tyndal's "Heat a Mode of Motion," fourth edition, p. 330.

to currents that deflect the needle above 15° to show how the increments of degrees above 15° also indicate equal increments of current strength.

5. It was not, however, until Sir William Thomson introduced his celebrated mirror-galvanometer in 1858 that shunts became of practical importance to telegraphists. It was he also who introduced the very expressive and useful term "shunt." By applying to his galvanometer three shunts, $\frac{1}{9}$, $\frac{1}{99}$, and $\frac{1}{999}$ of the resistance of the coils, so that its indications might be multiplied 10 times, 100 times, and 1000 times, he brought this exquisitely sensitive instrument within the reach of ordinary working currents, and made it one of the most valuable, if not the most valuable, apparatus ever furnished to the telegraph engineer.

The *rationale* of the instrument is given in the previous equations, and shown in fig. 4.

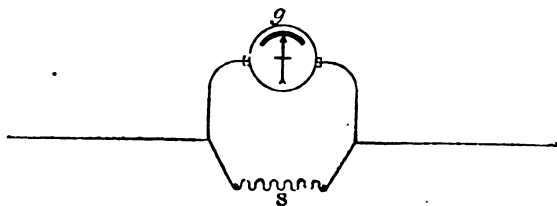

Fig. 4.

Equation (3) gives the joint resistance (G) of a galvanometer (g) and its shunt (s),

or
$$G = \frac{g s}{g + s};$$

and equation (6) gives the resistance of the shunt to provide any given multiplying power (n) required,

or
$$s = \frac{g}{n - 1}.$$

Thus the multiplying power (n) of any shunt is

$$n = \frac{g + s}{s} = \frac{g}{s} + 1.$$

It must, however, be noted that these equations are subject to the corrections given in (c. 5.) and to the condition that the shunts do

not introduce any errors from induction, which will be referred to later on.

It is also worthy of note that, when measurements of the strengths of different currents are made by passing those currents direct through a galvanometer, an adjustable shunt enables the *same deflection* to be obtained in each case, and thus all error due to the deflections of the needle not being proportioned to the strengths of the currents which produce them are avoided.

Mr. Latimer Clark* has pointed out an error in the measurement of currents of short duration when using galvanometers with shunts, due to the electro-magnetic induction of the swinging needle upon the coils. The motion of the needle tends to produce in the coil within which it is suspended a current in the opposite direction to that which moves it—(*vide F et sequitur*). Thus the reading is always below its true value. The error is reduced to a minimum by using very high resistance in circuit, or by using one of the so-called “nul” methods.

6. Mr. Latimer Clark, in 1859, applied a shunt of small resistance to an ordinary galvanometer or “detector,” wound with fine wire, to measure the so-called “quantity” of a battery. The term “quantity” is still frequently used by telegraph engineers to express the relative strengths of currents given by batteries when on short circuit. It is evident that the so-called “quantity,” in the case of batteries, simply depends upon the electromotive force and internal resistance of the cells, and the only difference between a “quantity” and an “ordinary” battery is that one possesses less internal resistance than the other. Nevertheless, the term is exceedingly useful when applied to currents of induction and to charges and discharges from cables and condensers, for without altering the resistance of the circuit, or the intensity of the electromotive force, it is possible by varying the capacity to pass a greater quantity of electricity through the circuit in a given time, and therefore to increase the strength of the current. In this sense one current is said to have greater quantity than another. The equation $C = \frac{Q}{t}$, sometimes called Faraday’s law, expresses the relation that exists

* Journal of S.T.E. January, 1873, vol. ii. page 16.

between current, quantity (Q), and time (t), and it shows that the strengths of currents can be measured by the quantity of electricity which flows in a given time. Galvanometers wound with thick wire so as to offer an inappreciable resistance to the current, and called "quantity" detectors, were used to measure the so-called quantity of batteries, but Mr. Latimer Clark effected precisely the same object by inserting a small shunt between the terminals of an ordinary detector, and thus dispensed with the necessity for carrying two galvanometers on the part of those engaged in the maintenance of telegraphs.

7. The author, in 1859, applied a shunt to one wire of a differential galvanometer so as to multiply the readings of an ordinary box of resistance coils.

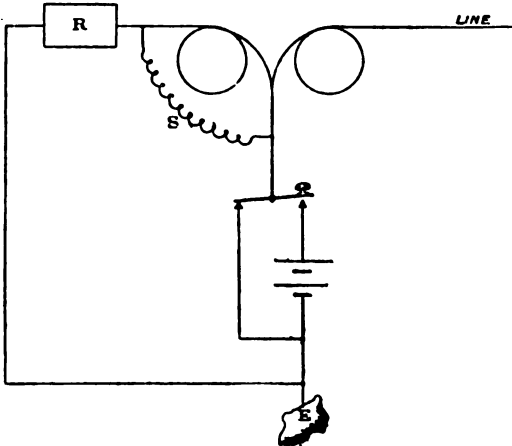

Fig. 5.

By making the shunt (s) fig. 5, $\frac{g}{n-1}$, g being the resistance of one wire, the value of the rheostat R would be multiplied n times, or by reversing the rheostat and the line reduced $\left(\frac{1}{n}\right)^{th}$ times. Thus an ordinary box of $10,000\omega$ with a $\frac{1}{10}$ shunt ranges from $\cdot 1\omega$ to $100,000\omega$. This instrument was called a "multiplying differential galvanometer." *

8. Mr. C. F. Varley † in 1861 applied $\frac{1}{10}$, $\frac{1}{100}$, and $\frac{1}{1000}$ shunts

* Minutes of Institution of Civil Engineers, vol. xx. 1860-61.

† C. F. Varley, Patent No. 3078, 1861.

to one side of a differential galvanometer for a similar purpose, and Mr. Latimer Clark,* in 1868, introduced a double-shunted differential galvanometer, in which $\frac{1}{100}$ shunts were applied to each wire of the instrument, so that either half so shunted could be thrown in at pleasure.

9. The use of such instruments was, however, rendered practically unnecessary by the improvement and general adoption of Wheatstone's Bridge by the Messrs. Siemens, which effected the same object in a more complete way.†

It is needless to recapitulate here the innumerable purposes to which shunted galvanometers are applied in practical telegraphy. No delicate quantitative tests, either for insulation, resistance, or capacity, are taken without their aid. Nor are any of the accurate tests for the resistance and distance of faults in submarine cables, so fully detailed in text-books and hand-books, relied upon unless taken by their agency.

E.—Early use of Shunts for Working Purposes.

1. We will now consider the application of shunts to the practical working of telegraphic circuits.

In the early days of telegraphy in England the form of printing-instrument which was used was that of Bain's Recorder, where the marks were made upon chemically-prepared paper by the electrolytic action of the received currents. *n* (fig. 6) was a needle of fine iron-wire, resting upon the paper-ribbon P, which was moistened with a solution of potassium ferro-cyanide, and moved by clockwork below and in contact with it. The currents passing through the paper decomposed the solution and left behind them clear dots and dashes in Prussian blue (ferric ferro-cyanide).

Of the principal wires so worked were two between London and Liverpool, called the "Trent wires," which were used as Bain's circuits during the day and as a double-needle circuit during the night. In those days also circuits were very much affected

* Electrical Measurements, by Latimer Clark, London, Spon, 1868.

† Outline of the Principles and Practice involved in dealing with the Electrical conditions of Submarine Electric Telegraphs. By Werner and C. W. Siemens, *B. A. Assoc.*, 1860.

by "weather" contacts, the currents on one circuit leaking through the insulators and their supports into the other circuit,

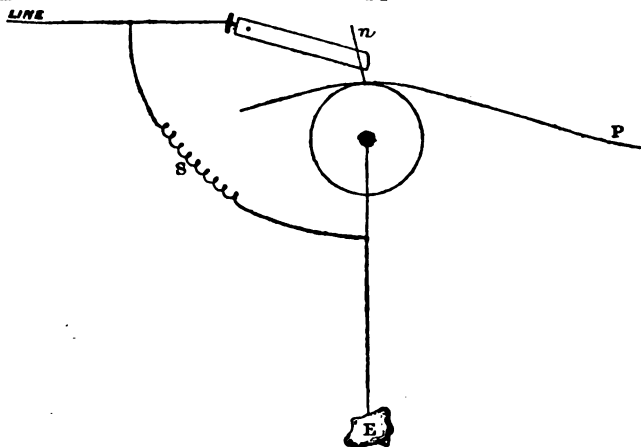

Fig. 6.

and making such marks upon the paper as to interfere with and frequently to stop their working. Mr. John Fuller, in 1856—who was then in engineering charge of the Liverpool station—finding that these "contact" currents were almost invariably weaker than the received "line" currents, conceived the idea of inserting a shunt S (fig. 6) between the line and the earth-wires, so as to reduce their strength below the point of interference, leaving the line currents strong enough to record signals.

The shunt was a set of coils, constructed of fine iron wire, insulated with silk, each coil being made of different lengths and arranged so as to be adjustable to suit the varying strength of the contact currents due to changes in the weather. The result was successful. The marks came out clear and good, and the working of the circuit was materially improved. The introduction, however, of polarised relays and double-current working, and of earth-wires upon the poles, together with better insulation, entirely removed these effects of contact. The Bain's also succumbed to the less troublesome and cleaner, though far coarser, Morse, so that these shunts went out of use and are now well-nigh forgotten.

2. But they probably owed their salutary influence as much to another cause as to the mere shunting of the interfering currents

—as was then imagined—and this was to the effect produced by the secondary or “extra” currents, generated in the coiled shunts by the so-called self-induction of the line-currents.

F.—*Electro-Magnetic Induction.*

1. Any portion of space subject to magnetism, and so influenced as to exert magnetic power on magnetic bodies brought into it, is called a *magnetic field*. Faraday* has shown how the intensity and direction of the force in this field can be indicated by conceiving the existence of lines of magnetic force in that field whose direction at any point coincides with the direction of the force at that point, and whose number through unit-area is proportional to the magnitude of the force.

2. It is well known that whenever a current of electricity passes through a wire it converts the neighbourhood of that wire into a magnetic field, whose lines of force are circles, in planes at right angles to the wire, having the wire for centre. Conversely, whenever a magnetic field crosses or is passed through a wire, or a wire crosses or is passed through a magnetic field, the conditions for a current are determined—a difference of potential is produced at the extremities of the wire—and if the circuit be complete a current flows.

3. In the first case the intensity of the magnetic field is proportional to the strength of the current producing it, and in the second case the strength of the current is proportional to the intensity of the field producing it.

4. Again, in the first case the direction of the lines of force in the field depends on the direction of the current, and in the second case the relative position of the higher and lower points of potential depends not only on the direction of polarity of the lines of force, but on their direction of motion. Thus, when a current is suddenly formed in a wire, the lines of force about it may be said to be projected outwards, and to move in one direction, and when the current suddenly ceases they are drawn in as it were, and move in the opposite direction. Hence, a magnetic field is passed through a wire placed near another wire in opposite directions whenever a current begins and whenever it ceases, and thus are produced the initial

* *Experimental Researches*,—Series xxviii. 1851.

and final secondary currents in induction coils. The duration of the secondary currents is dependent upon the duration of the motion of the field. As long as the influence producing the field is increasing or decreasing, so long may the field be said to be in motion, and so long are the conditions that determine the induced currents existent. Thus the duration of the induced currents varies with the period of increment or decrement of the strength of the primary current.

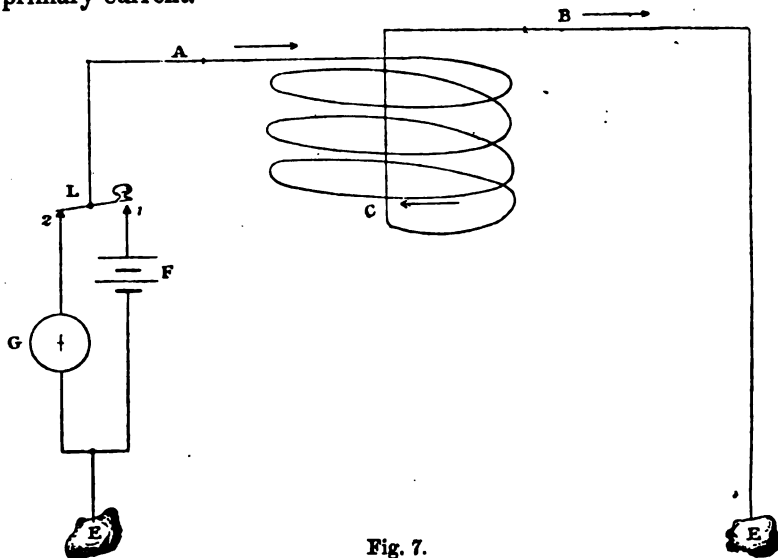

Fig. 7.

5. Now, let us take the case of the coil C (fig. 7), which may be two or three hundred yards of fine silk-covered wire wound upon a boxwood reel, such as is usually employed for electro-magnets in telegraphic apparatus. Let a current by means of the key L be sent through this coil in the direction shown by the arrows. Each turn of this coil produces a magnetic field about it, and, as each magnetic field passes through every other coil above and below it, a difference of potential is determined in each coil in the same direction, which, therefore, accumulating in series, produce a resultant difference of potential between A and B. The magnitude of this difference will evidently depend upon the intensity of each field and on their number, and therefore will vary with the strength of the current producing the field with the dimensions of the core and *with the number* of turns in the coil.

6. The relative position of the potentials will depend upon the direction of the current through the coil, for, if the direction of the main current through the coil be reversed, then the direction of the lines of force in the field also will be reversed.

7. When the current first flows the lines of force, as already mentioned, may be conceived to be projected outwards, and when it ceases they are drawn inwards. Hence this difference of direction of motion produces a difference in the sign of the potential at A, when contact is made and when it is broken. Now (fig. 7), when contact is made at L, and a positive current flows in the direction from A to B, as shown by the arrows in C, it is found that the potential of the point A is increased above, and that of B reduced below, that due to the main current. When contact is broken, the reverse effect takes place—the potential of A is lowered and that of B is increased with respect to the potentials due to the main current. It is the same as though the coil were replaced momentarily by an electromotive force *opposing* the main current at its commencement, and *acting with it* at its cessation. We may conceive A for the instant to be the copper and B the zinc pole of an interpolated battery when contact is made, and A the zinc and B the copper pole when contact is broken. The result is, that the strength of the main current is reduced at its commencement and continued at its cessation.

13. The variation in the flow of currents is graphically shown by a curve $a c b c_1 a_1$ (fig. 8), where the abscissæ ab and ba_1 represent the duration of the currents, and the ordinates $c' c$ and $c'' c_1$ their strength. This curve would be made by the spot of light of a mirror-galvanometer at the end of the Atlantic cable when actuated by a positive and then a negative current, if it were photographed on a moving sheet of paper, and it is actually made in practice by the ink-line in Thomson's Recorder.

14. If positive currents reach their maximum strength instantaneously and lose it as rapidly, such as those which make dashes on short telegraph lines, they would be represented by $+c$ or $-c$, but if they arrived at the end of a long submarine cable, attaining their maximum slowly and losing it as slowly, they would be represented by $a c b$ and $b c_1 a_1$. In the same way the effects of self-induction at the commencement and cessation of main currents

would be shown by the curves bb_1 on *short circuits*, which, however, are exaggerated for the sake of illustration. The induced currents on short circuits are evidently momentary, for the primary currents assume their maxima and lose their strengths instantaneously.

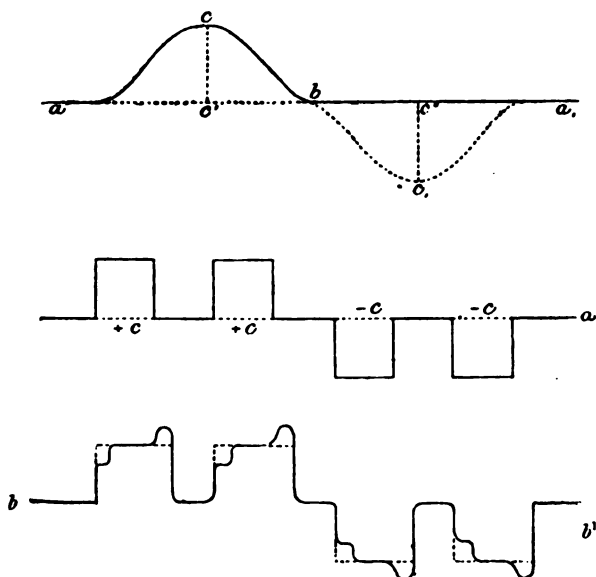

Fig. 8.

neously; but on submarine cables, or on long land-lines, their duration must vary with the periods of the increment and decrement of the primary currents (fig. 4).

15. These effects are very clearly observable on coils of gutta-percha wire, especially when they are wound on iron reels. Upon coiled cables they produce what is known as "false" discharge. They are very considerably increased by filling the interior of any coil with an iron core, in other words, by converting the coil C (fig. 7) into an electro-magnet. Not only is the strength of the magnetic field thus greatly increased, but the important element of *time* is also introduced. It is well known that iron takes time to acquire magnetism and time to lose it.* Moreover, the time which iron takes to acquire and lose magnetism depends essentially on its form and on the work it has to do. The speed of

* Faraday's "Experimental Researches," Series xx. § 2332.

signalling on many instruments, and the number of strokes upon electric bells in a given time, are reduced by this action of time.

16. Ruhmkorff, whose induction coils have acquired such universal reputation, owes his success principally to the system he introduced by which his iron core instantly acquires and loses its magnetism. It was to determine the influence of form on magneto-electric induction in the coils of telegraphic apparatus that the following experimental investigation was made.

F.—*Experimental Investigation.*

On short circuits and upon simple coils the effects of induction are so instantaneous that they can be detected only by physical shocks, but the change in the character and form of the iron soon brings the final current within the range and measurement of the galvanometer. The initial effect cannot be traced by an ordinary galvanometer, for it is mixed up with the main current, but the final effect can be eliminated from the main current and measured. If, for instance, in fig. 7 the key L make a back contact at 2, which is in connection with the earth through a galvanometer G, then, every time this contact is made after a current is sent, the final current due to self-induction—the “extra” current—will pass through G, whose strength will vary with the amount of induction present. Inasmuch, however, as the contacts at 1 and 2 are made by hand, their duration becomes variable and uncertain, and the results

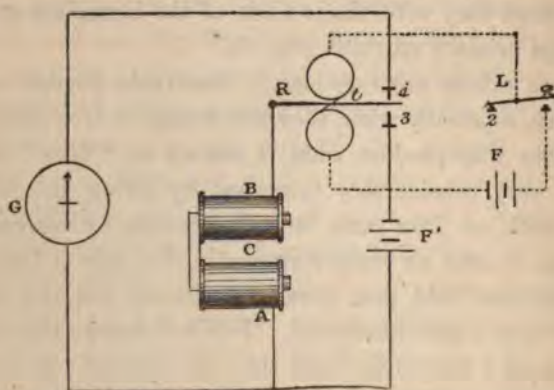

Fig. 9.

conflicting. To make the conditions and contacts invariable, a *Siemens's relay R* (fig. 9) was inserted in the circuit of F, which

normally maintained a current from F' through the coil by means of 3 and the tongue t , and which put the galvanometer G in circuit by means of 4. Every time the key L was depressed the tongue t flew from 3 to 4, establishing a circuit through G for the formation of the extra current. Thus the current due to the final difference of potential between A and B , at the cessation of the main current, was observed on G . The galvanometer G was one of Thomson's reflecting galvanometers. The key L was an ordinary Morse single-current key. The battery F' used was an ordinary Daniell's of 20 cells. The battery F was then of the same form as F' , but of 10 cells. The coils experimented upon were those of the electro-magnet of an ordinary direct ink-writer. In every case an average of about 20 observations was taken, the results being reduced by shunts to comparable numbers. The strength of the extra current from a single coil with an iron core being taken as the *unit*, all other results were reduced in terms of this unit.

I. The first series of experiments was made with a single coil, the iron pieces used being those belonging to the electro-magnet of which the coil formed part. I have indicated upon the diagram itself the position of the pieces and the number of the experiment. The results are wonderful. The observed strength of the extra current in (7) is 361 *times* that of (1).

Fig. 10A. 1 represents the unit coil which replaced AB in fig. 9,

Fig. 10A.

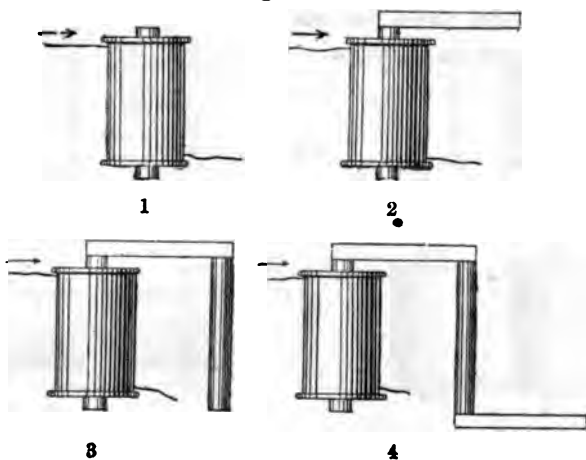

and gave an extra current, which I have taken as unit for comparison.

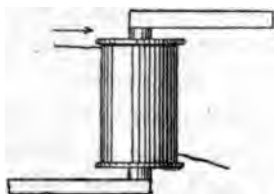

5

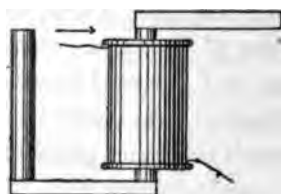

6

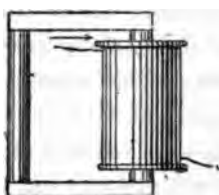

7

2 gave a current = 13.	5 gave a current = 63.
3 ditto = 26.	6 ditto = 102.
4 ditto = 33.	7 ditto = 361.

II. The second series was made with the two coils, and pieces of iron were put on as shown.

Fig. 10B.

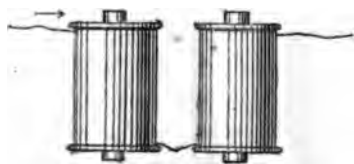

8

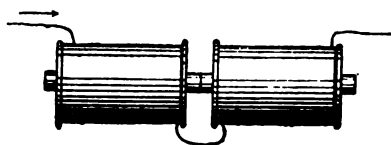

9

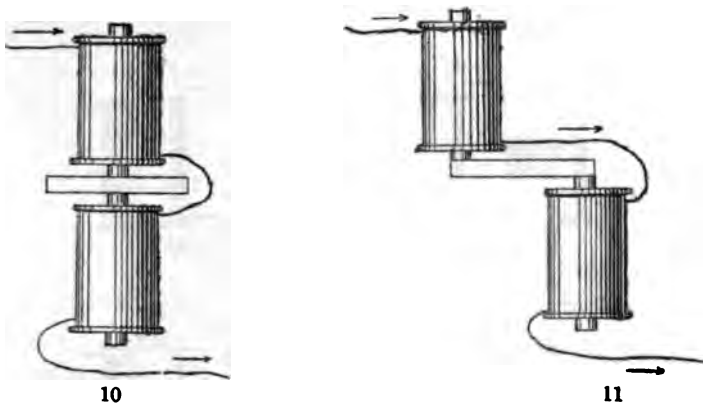
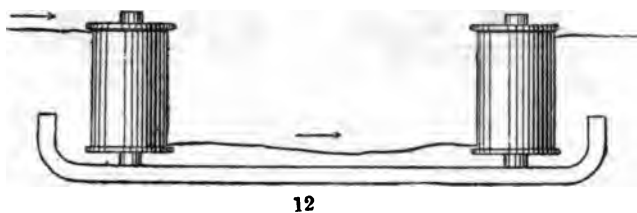

Fig. 10c.



8	gave an extra current	=	17.
9	ditto ditto	=	184.
10	ditto ditto	=	195.
11	ditto ditto	=	228.
12	ditto ditto	=	304.

Fig. 10D.

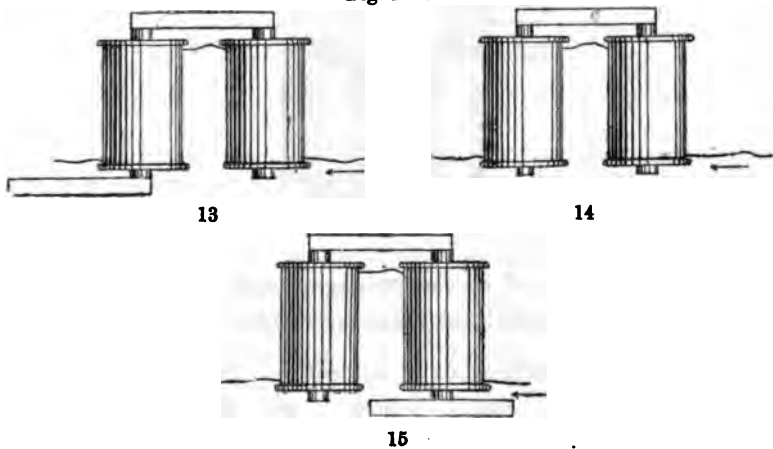

Fig. 10E.

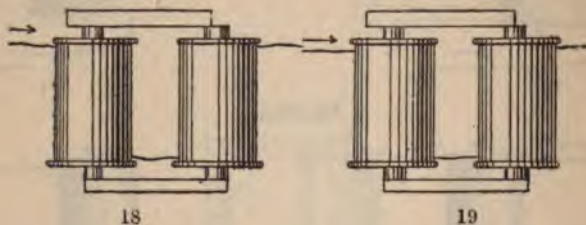
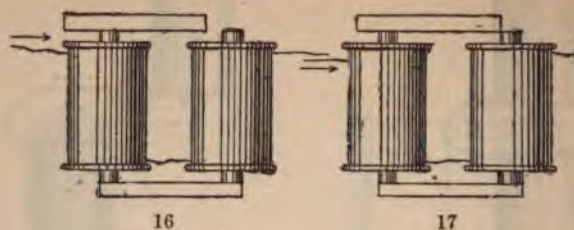
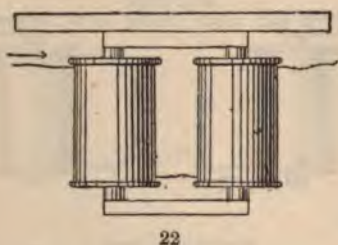
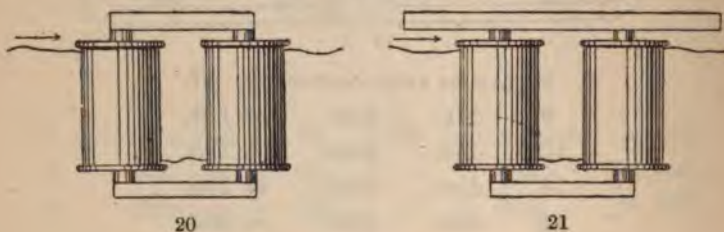

Fig. 10F.



The ordinary form of an electro-magnet with the soft iron cross-piece was next tried, with the following results:—

13	gave an extra current =	347.
14	ditto ditto =	496.
15	ditto ditto =	557.

16	ditto	ditto	= 735.
17	ditto	ditto	= 1,060.
18	ditto	ditto	= 2,118.
19	ditto	ditto	= 2,238.
20	ditto	ditto	= 2,238.
21	ditto	ditto	= 2,238.
22	ditto	ditto	= 2,238.

In experiments 15, 16, 17, 18, 19, and 20 the armature was gradually shifted or slid on to its final position, where it reached a maximum current 2,238 *times* that of the unit current! Experiments 20, 21, and 22 show that no additional effect is produced by increasing the mass of iron in contact with the poles.

III. The maximum effect of the coils joined up in "series" being a current 2,238, the result of joining up the coils in "quantity" (fig. 11) as opposed to series was tried. The result was that the effect was reduced to 502. This is what might be expected, for the electromotive force is now that of only one coil, and the main current in each coil is reduced one-half, consequently the effect observed in quantity should be only one-fourth of the effect in series.

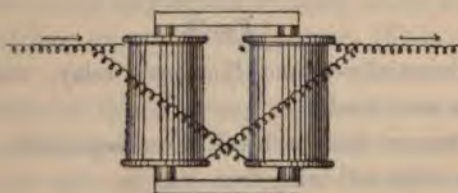

Fig. 11.

IV. Experiments 15 to 21, showing that the sliding on and off of the armature offered a convenient means to increase and decrease the strength of the extra currents at pleasure. The effect of withdrawing and inserting the iron cores was next tried as shown in fig. 12. The results are tabulated—

Length of core in	$\frac{9}{8}$	$\frac{7}{8}$	$\frac{6}{8}$	$\frac{5}{8}$	$\frac{4}{8}$	$\frac{3}{8}$	$\frac{2}{8}$	$\frac{1}{8}$	$\frac{0}{8}$
Extra current }	347	135	67	27	12	4	·86	·14	0

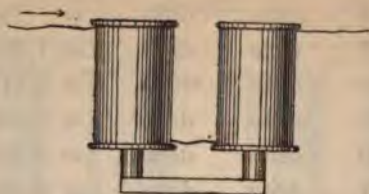

Fig. 12.

V. As the pole pieces $p p^1$ of a Siemens's relay are moveable, the effect of shifting them was next tried.

Distance of poles apart.	$\frac{6}{1\frac{1}{2}}$	$\frac{5}{1\frac{1}{2}}$	$\frac{4}{1\frac{1}{2}}$	$\frac{3}{1\frac{1}{2}}$	$\frac{2}{1\frac{1}{2}}$	Very nearly touching.	Touching.
Extra current }	1688	1733	1823	1958	2273	3295	3680

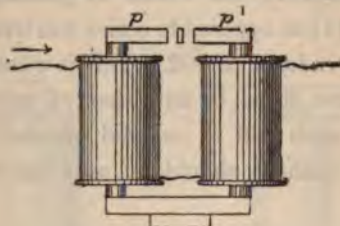

Fig. 13.

VI. A differentially-wound Siemens's relay, used for duplex working, was next tried :

1. The current from each coil taken separately, the other coil being free, was 360
2. When the one coil was short-circuited the current from the other was 623
3. When the coils were joined up in quantity the current was 196
4. When they were joined up in series the current was 853
5. When they were joined up in opposition, the current in one coil being in the reverse direction to that in the other, the current was Nil.

Poles about one-half inch apart.

VII. Different forms of relay arranged for ordinary working were next taken, and their relative self-induction measured. The results were for—

Siemens'	1688
Stroh's ordinary	1621
„ polarized	1500
Theiler's No. 1	279
„ No. 2*	26

G.—*Inferences from Experiments.*

1. We thus see what a marvellous influence the form of the electro-magnet has upon the extra current. The nearer the core of the magnet approaches in form the unit coil the less will be the induction, and hence the superiority in this respect of Theiler's relay. The more it approaches a closed curve of iron the greater the effect, and hence the failure of Siemens's relay—otherwise so perfect—for rapid transmission.

2. We have also here a source of electricity, the currents of which, though short in duration, can be varied in their strength at pleasure, either by varying the resistance of the circuit through which they flow, or by varying the intensity of the field producing them, (1) by sliding on or off the armature, (2) by moving in or out the cores.

3. The duration of these currents is evidently dependent on the rate at which the magnetism of the core dies out, and this in turn is affected by the extra current, so that in a closed curve we have a series of reactions or reverberations, as it were, between the magnetism of the core and the extra currents.

4. How much of the effect observed on the galvanometer is due to the momentary character of the currents and their prolongation through slow demagnetization, and how much to an absolute increase in the intensity of the magnetic field, and the consequent increase in the electro-motive force, remain for further inquiry. It is well known that with the same electro-motive force the deflection of a galvanometer will vary with the duration of contact for very

* The cross-piece of the electro-magnet was removed in No. 2, reducing it to the form shown at 8, fig. 10B.

short intervals, but this source of error has been diminished as much as possible by using the same deflection and varying only the shunt (§ D 5).

5. We may reason from the foregoing that the smaller the mass of iron forming the core, and the less the length of wire encircling the electro-magnet, the less will be the induction. Hence, to remove the effects of electro-magnetic inertia as much as possible from relays, we are now reducing the resistance and size of the electro-magnet as much as possible—a course opposed to that which has been hitherto the practice. We know that to obtain the maximum magnetic attraction of the current the resistance of the relay should approach that of the line, but rapid telegraphy has taught us practically that such a course leads to retardation, and these experiments show the cause. Low resistance, however, and small magnets, involve much trouble in adjustment, hence a compromise has to be effected between experience and theory. The present resistance of relays on fast-speed circuits in England is about 300^{ω} .

6. The experiments (VI.) on differential relays explain why it is that experience has shown that this system of working duplex is preferable to the bridge method. The disturbances from extra currents are less in the former than in the latter.

7. Experiment III. shows how the effects of induction can be reduced to a minimum on existing apparatus. It will be shown further, on (K 7), how advantage of this method is taken to increase the rate of working.

H.—*The Effects of the Magneto-Electric Induction.*

1. The effects of magneto-electric induction, which are thus so well shown by experiment, are distributed in actual working through the circuit and apparatus, and their results upon ordinary circuits worked by electro-magnets is to produce what has already been referred to as “electro-magnetic inertia”—a sluggish action of the apparatus, producing retardation of signals and a reduction of the speed of working.

2. Their influence is entirely removed from simple coils, such as those used in rheostats, or for shunts, by double winding—as shown in experiment VI. 5—two wires being wound together, and so joined

that the current traverses one-half in one direction and the other half in the other direction—thus each half neutralizing the inductive effect of the other half.

3. The extra currents generated in the coils of a Morse recorder or a sounder, when worked by a relay, have a deteriorating influence upon the points of contact completing the local circuit in the relay. They appear as sparks, and cause the contact-points to become oxidized, sometimes even to be fused, and always to be dirtied, so as to introduce increased resistance. They are removed by inserting a shunt across the ends of the coils of the Morse electro-magnet (fig. 15), whose resistance is about 40 times that of the coils. This was devised by Dering in 1854, applied by Dujardin in 1864 to his type-printer, and introduced by Mr. Culley in translating or repeating relays.

4. A simple coil arranged as a shunt is called a *simple shunt*. If it have an iron core, or if it be an electro-magnet, it is called an *electro-magnetic shunt*.

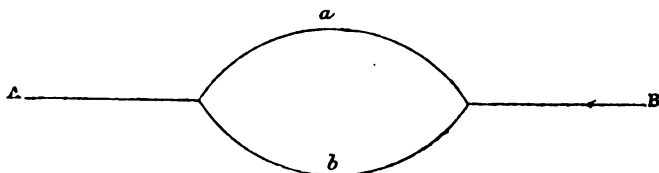

Fig. 14.

5. Let us first of all consider the case of a simple shunt, in which self-induction is neutralized. If there be no electro-magnet in *a* (fig. 14) the effect is simply that of a multiple arc, reducing the resistance of the circuit and introducing no disturbing element; but if there be an electro-magnet, such as a relay, in *a* (fig. 15), then must the influence of the "extra current" be felt in four ways—first, by the reduction in the strength of the first appearance of the main current; secondly, by the increase in the final strength and apparent continuance of the main current through B; thirdly, by the formation of a current in the path S; and fourthly, by a current through A. If the ends A and B were disconnected at the same instant that the main current ceased, the whole extra

current would flow around the figure $V S V' a$ only, but if the line were to be put to earth at A and B these currents would flow through each branch of the circuit.

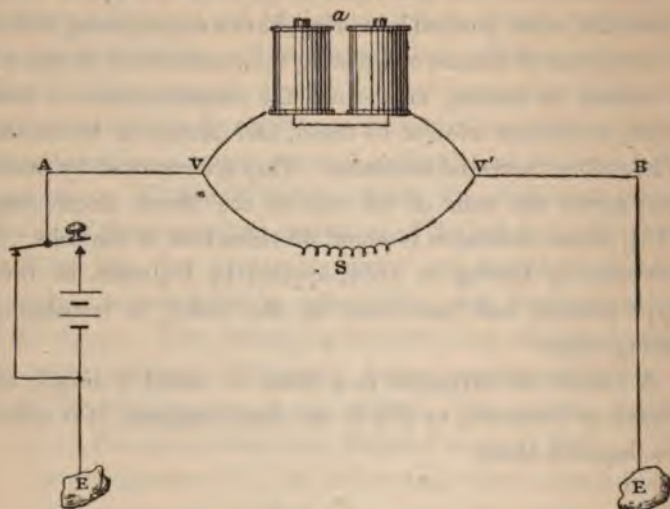

Fig. 15.

6. Let us examine the extra currents in the different branches of the multiple arc. This is best done by conceiving the electro-magnet replaced at the instant when the main current ceases by an electromotive force E (fig. 16). The extra currents produced thereby are shown by the arrows.

I. In the simple line circuit it is evident that the extra current traverses the whole circuit and expends its whole force upon the apparatus, prolonging its action.

II. In the case of the simple shunt the extra current has the additional path s to traverse, and, though the strength of the main current passing through the electro-magnet is reduced, that of the extra current through the apparatus is considerably increased, because it has a shorter circuit, and therefore less resistance to overcome.

III. In the case of the magnetic shunt, when everything in each branch is similar, then the extra current in the one branch opposes that in the other branch shown by the dotted arrows, with a strength

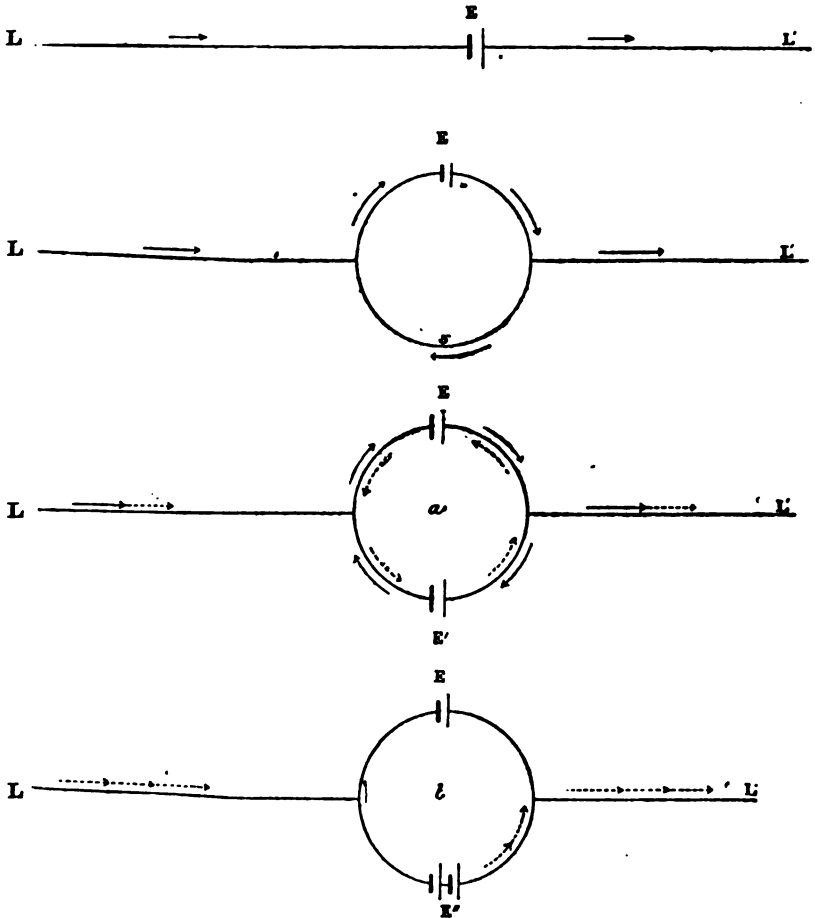

Fig. 16.

dependent upon the resistance of the line LL' . If this resistance be very small, then the extra current in one branch is unaffected by that in the other, for they flow in independent circuits; when this resistance is *infinite*, then each extra current completely neutralises the other. As the resistance of LL' varies from nothing to infinity, so the influence of the shunt approaches neutralization. In the line LL' itself the extra currents from each branch combine and vary from a strength equal to the sum of the two to nothing, according as the resistance varies from nothing to infinity.

IV. If the field of the magnetic shunt be more powerful than

that of the relay then the extra current from the shunt can overpower that of the relay and produce a current in the relay in the reverse direction to the main current, or it can exactly neutralize it, as shown in the figure, where the neutralised currents are omitted.

7. It is evident that by varying the form and dimensions of the electro-magnet in the shunt, by sliding on its armature, or by withdrawing its core, it is easy to adjust its extra current so as to neutralise exactly or to overpower the extra current in the main circuit whatever be the resistance of LL' .

8. Thus we see that—while in the first case the whole of the extra current is expended in producing electro-magnetic inertia in the apparatus, in the second case the extra current is much increased together with its effects of prolongation, and in the third and fourth cases, that, while the extra currents in the line are increased, those passing through the apparatus are considerably reduced and may as in the last case be completely neutralized—the action of the extra currents in the line L is to neutralise the effects of electrostatic induction, as we shall see further on.

I.—*Later use of Shunts for working purposes.*

1. It is well known that the principal mode of working Morse circuits in England is the double-current system, where the action of a current reverse to that making the marks replaces the antagonistic spring in relays, making them self-adjusting, and assisting in the clearing of wires of the charge due to static induction. In repeating or translating this system Mr. C. F. Varley, who introduced it in England, found it necessary to devise an automatic reversing switch or “zinc sender” as it was called. He used two relays, the one for the marking currents working the Morse, the other for the spacing or reverse currents. It was necessary that the armature of the electro-magnet of the zinc sender should be maintained in contact with its poles during the time a message was being sent and during that time only. To do this Mr. Varley inserted as a shunt a series of induction plates, composed of lead or carbon charged with diluted sulphuric acid, in fact a secondary

battery. The local current polarised these plates and caused them to set up, when the local current ceased, a current in the same direction, which by prolonging the action of the electro-magnet held down the armature.

Induction plates, however, proved to be so variable in action that various plans were tried to improve upon their action. Mr. Higgins (Assoc. S.T.E.) in 1866 discovered the prolonging action of the shunt (H. 5), and found that it effected the purpose with a success that left nothing to be desired. The induction plates were simply replaced by a shunt whose resistance was equal to that of the electro-magnet (fig. 15).

2. It is easy to show that the maximum effect is produced when the resistance of the shunt is equal to that of the electro-magnet.

Let C be the whole current, c_1 be the current flowing through the magnet r , and x the shunt. Then equation (5) gives us

$$c_1 = C \frac{x}{x + r}.$$

Let C^1 be the extra current produced on the cessation of the main current. The strength of this current will depend directly upon the strength of the current (c_1) through the coils, inversely on the resistance of the circuit through which the extra current flows ($x + r$), and directly upon a constant (k) whose value depends upon the form and size of the magnet. Thus—

$$C^1 = \frac{c_1 k}{x + r} = C k \frac{x}{(x + r)^2},$$

the differential co-efficient of which is—

$$\frac{d C^1}{d x} = \frac{1}{(x + r)^3} \{ (x + r)^2 C k - C k x (2x + 2r) \}.$$

Now at a maximum this = 0.

Therefore—

$$\begin{aligned} (x + r)^2 &= 2x (x + r), \\ x + r &= 2x, \\ \therefore r &= x. \end{aligned}$$

This assumes the external resistance so great that the value of x does not alter the strength of the main current C . A more general solution is given in the Appendix.

11. Mr. Schwendler introduced in 1871 in India a similar method to put the sending end of long circuits momentarily to earth so as to prevent the return currents from passing through and de-adjusting the receiving relays. The sending current was passed through a relay of small resistance, which was provided with a shunt of similar resistance, so that the contact of its tongue was prolonged long enough to carry off the discharge.

12. In 1868 it was found that the London and Cork Morse circuit suffered so much from leakage through the South of Ireland, where the atmosphere is exceedingly moist, that the received currents at Cork were at times too weak to be relied upon. Mr. Louth conceived the idea of placing shunts at Wexford and Waterford, which were upon the same circuit, so as to spare or pass on as it were some of London's current to Cork (fig. 17). This was found not only to effect the desired result, but that even those stations which were apparently robbed of their current read equally well. This plan has since been applied to other circuits, and it is now in use on the Athlone and Westport Morse circuit, which has seven intermediate instruments upon it. The speed of working these circuits by hand is not such as to be affected by the prolonging effect of the shunt.

13. Mr. Robert Sabine (M.S.T.E.) has also recently introduced shunts in a similar way upon a bell-circuit in the House of Commons. Bells were joined up in circuit and worked by an induction coil. They would not ring properly until shunts were introduced, as shown in fig. 18. They now ring perfectly.

14. The circuits in India are almost invariably worked on the single-current system, with positive currents only. They are as a rule very long, and the stations are few and far apart. At some small stations signallers come or break in circuit at certain fixed times, but at most stations, where only one signaller is kept, two Siemens's relays are joined up in multiple arc (fig. 19), so that whichever side of the circuit calls his attention is obtained.

15. Sir William Thomson has applied shunts to his beautiful Siphon Recorder for two purposes, first, to regulate the size of the received signals spurted upon the paper ribbon, and secondly, to enable the recorder at the sending-station to register the signals

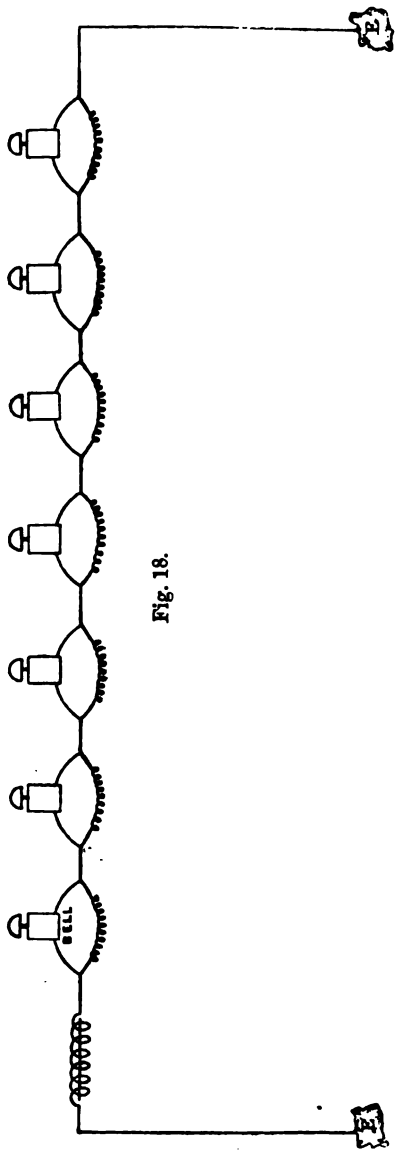
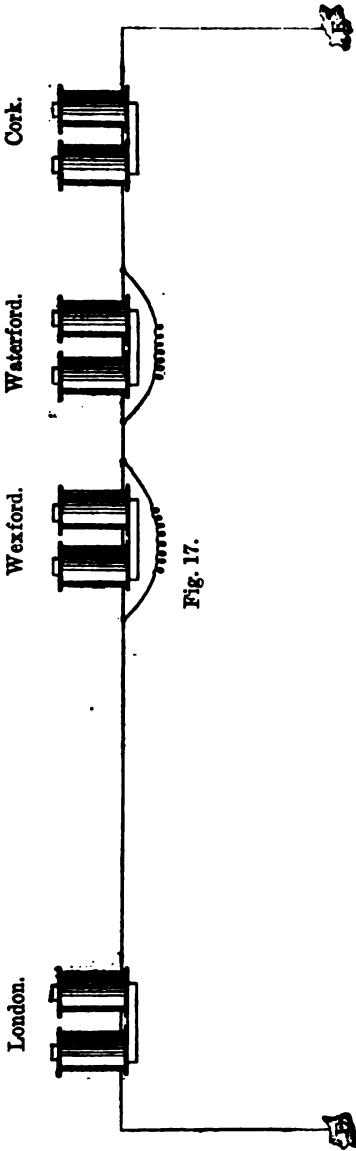

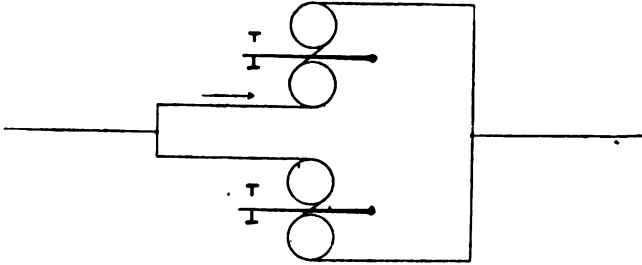

Fig. 19.

that are being sent. Fig. 21 shows how these two operations are done.*

16. In Hughes's beautiful type-printing instrument (fig. 20)

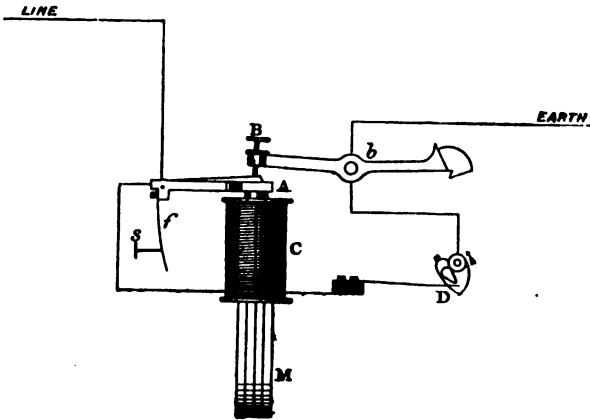

Fig. 20.

the electro-magnet is formed of two coils, with hollow soft iron cores (C), each fixed on a pole of the permanent magnet M. The armature A is retained against the pole-pieces of the electro-magnet by the magnetism induced in the cores by the permanent magnet M, but the moment this magnetism is reduced by the passage of a current the spring *f*, adjusted by the screw *s*, forces away the armature. The moment the armature A strikes the screw B the coils are short-circuited, the current ceases to pass through them, but goes to earth direct. Thus a current of definite duration is sufficient to

* Vide p. 205, vol. v.

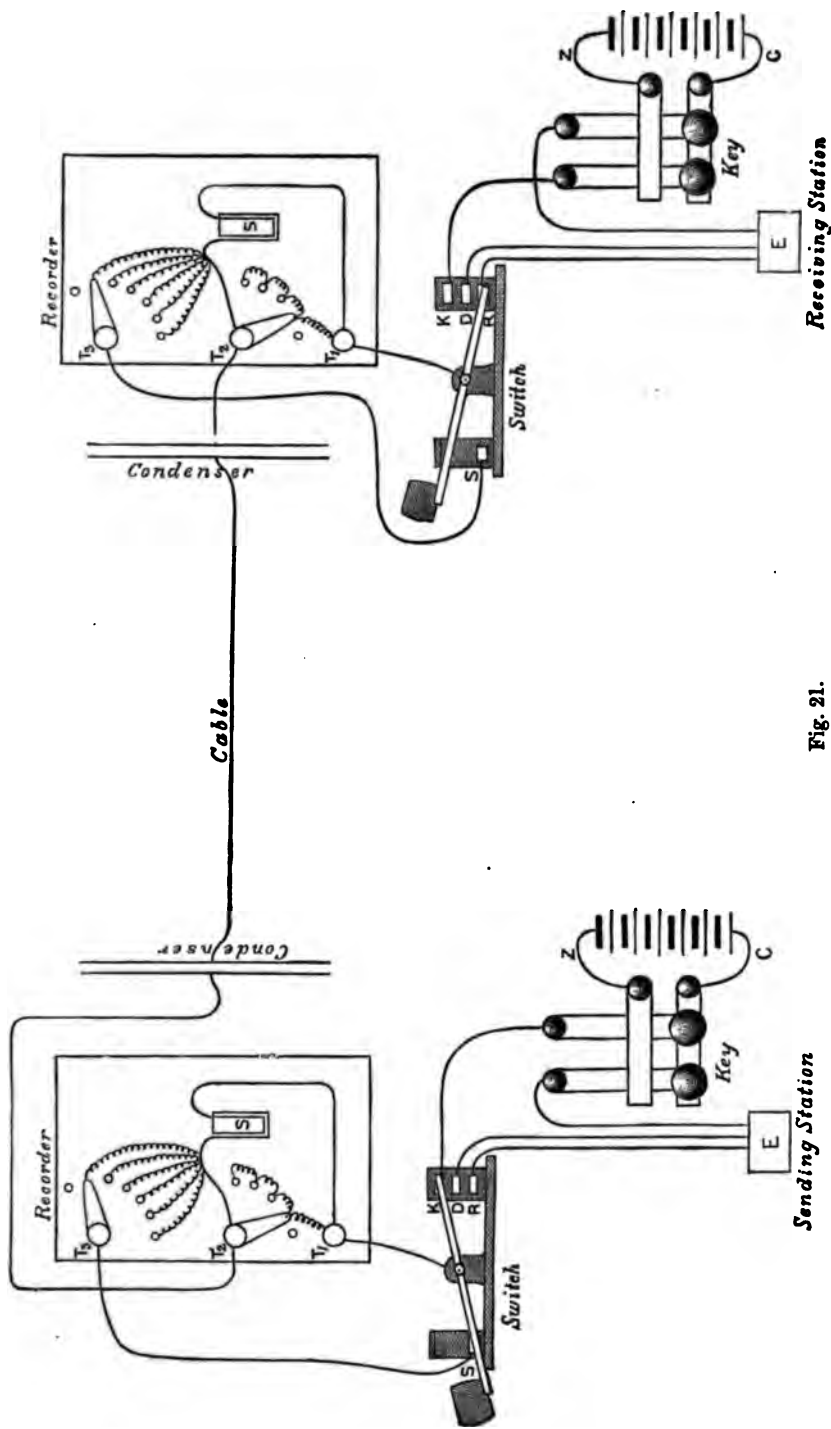

Fig. 21.

actuate the coils, and they are freed from any external disturbing influence. The armature is restored to its normal position by the mechanical action of the wheelwork. The mechanical removal of the armature and its replacement so influence the magnetic field about the coils that induced currents, in addition to the extra current, are produced by each operation, the first current being opposed to, and the second current being in the same direction as, the main current. This last current might have a disturbing influence, but its effect is nullified by the mechanical breaking of the circuit at D before the replacing of the armature, and making the circuit again immediately the armature is replaced.

J.—The Effects of Static Induction.

1. The appearance of the currents as they are received at the distant end of a short telegraph circuit has been graphically represented by curves $+c - c$ in fig. 8, as though no disturbing element existed, and as though the current in its commencement and in its cessation were sharp and decisive; but it is well known that upon all actual lines of telegraphy, whether overground or submarine, electrostatic induction modifies the flow of electricity so as to change the form of the current into something like that shown as $a c b_1 b c_1 a_1$ in the same figure, the particular form of curve depending upon the capacity of the circuit. We may represent the effects of static induction upon a long overground line on dots and on dashes (fig. 22). The result of this is to make the signals drag as it were, to cause the apparatus to work sluggishly, and to reduce materially the rate of working. 1 shows the form of dots and dashes on a short circuit, or as sent at the sending end of a long circuit, 2 shows their graphical representation as in fig. 8, 3 shows the appearance of these dots, and 4 gives their graphical representation if recorded upon chemically-prepared paper at the end of a long circuit. It is evident also from what has been said (E. 14, p. 16) that the retardation and prolongation of the line currents means a similar alteration in the duration of the extra currents.

2. Now, what was the effect upon these currents by the self-induction of a coil inserted as a shunt, as done in Liverpool? (§ E 1.)

Simply to restore, or to tend to restore, the line-currents to their proper form, as shown by the dotted curve in 5 (fig. 22), which is enlarged for the sake of more clearly showing the effect of an electro-magnetic shunt. The front slope is filled up as it were by the initial effect of the shunt, and the back slope is cut off by its final effect. The signals thus would tend to acquire their proper form and

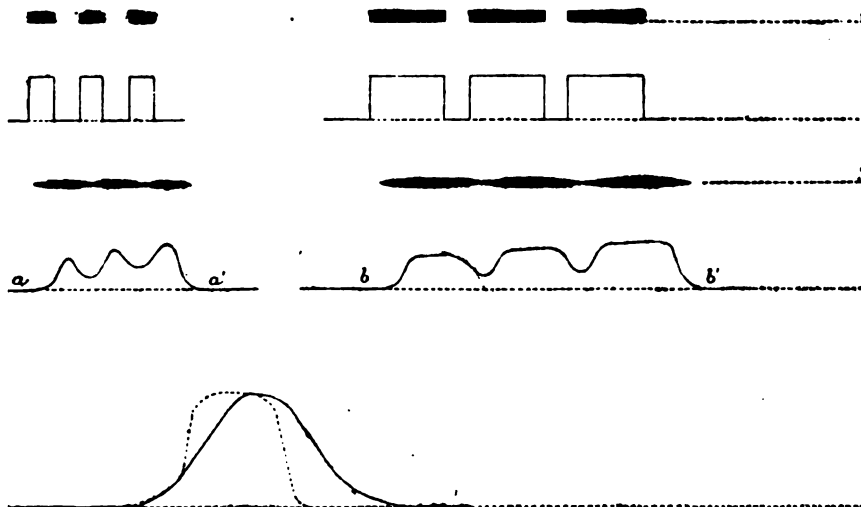

Fig. 22.

to become clearer. Moreover it is evident that they can be sent more rapidly after each other, for the line is more quickly cleared.

It is however but right to say that this inductive effect was not suspected at the time, and that the shunts were introduced solely to reduce the strength of the contact currents on the paper.

K.—*Use of Magnetic Shunts to compensate the effects of Static Induction.*

1. In 1862 Mr. C. F. Varley* introduced his mode of working submarine cables, which has been the basis of all the great improvements introduced subsequently by Sir William Thomson, Professor Fleeming Jenkin, and others. Among other plans he proposed that illustrated in fig. 23. G is a mirror-galvanometer or other instrument, C a condenser, and M a magnetic shunt or

* C. F. Varley, Patent No. 3453. 1862.

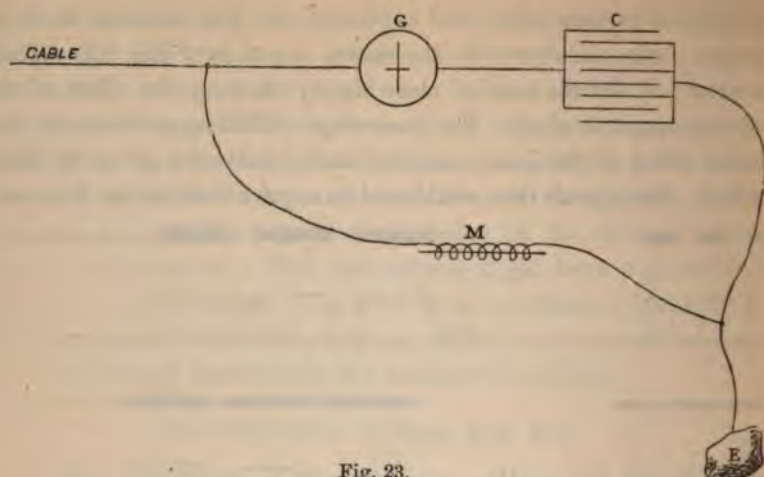

Fig. 23.

“a resistance coil (best if wound on large iron core).” Mr. Varley stated that the speed of transmission would not be increased without this shunt, but I am not aware that it has ever been used. The condenser has remained in general use for cable-working.

2. The drawing out or prolongation of the current due to static induction has the tendency upon relays—if currents are sent too rapidly—to make the armatures stick, and therefore to run the signals together. This effect is reduced to a minimum on non-polarised relays by adjusting the antagonistic spring so high as just to prevent the signals from being “light.” Mr. J. B. Stearns, in 1872, applied on the Sydney and St. Pierre section of the New York, Newfoundland, and London Telegraph Company, 228 miles in length, a simple shunt to the relay, which was closed by the sounder only, thus (fig. 24).

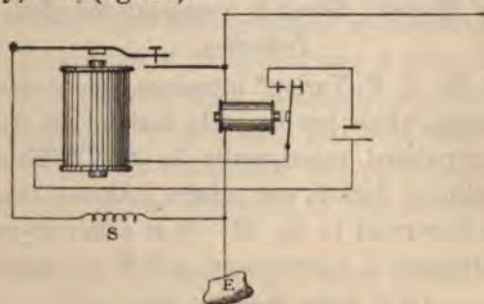

Fig. 24.

The shunt (S) had a resistance equal to that of the coil of the relay, so that when it was brought into circuit by the attraction of the armature of the sounder it reduced to one-half the strength of the line-current passing through the relay coils. It cut off as it were the current at half-stroke. Hence, by reducing the current through the relay, it made the relay more ready to open by the pull of the antagonistic spring when the current ceased, the spring itself was able to be adjusted somewhat slacker, and thus was ready to work quicker, and respond to an earlier appearance of the current. Sticking was therefore reduced, and light signals prevented.

It is evident also that the retarding effect of the final "extra" current in the relay was reduced one-half, for the strength of the current in the coils of the relay was reduced one-half. The effect of this shunt was to double the speed of working of that section of cable, and the method was speedily applied to all the sections of that line. It is now in use at Valentia, on the Anglo-American Company's circuits from London.

4. In 1872 Mr. Stearns introduced duplex working in America, and, studying the effects of static induction upon open lines and compensating for them, he made duplex telegraphy what it is—one of the greatest advances of telegraphy of the present day. His most successful mode of accomplishing this was by the use of condensers in the compensation circuit, but he also employed induction coils and electro-magnetic shunts, so as to make the extra currents neutralize the effects of static induction. Mr. G. K. Winter in India and Mr. D'Infreville in America have also successfully introduced magnetic coils to neutralise the effects of static induction on open lines when working duplex.

5. If R (fig. 25) be an ordinary polarised relay, and S be an electro-magnetic shunt, then (§ H 8) the extra current induced in S can be adjusted to overpower that in R, and be made to move the tongue t in the reverse direction to that due to the main current.

In this way not only can the tongue be made to move more quickly but it can be restored to its normal position against the insulated stop the instant the current ceases. Thus the action of

the relay is not only quickened but it can be made much more delicate, for the tongue can be adjusted to its most sensitive position, as is the case in double-current working. It becomes practically self-adjusting, for the instant it has done its work it is driven back again to its normal position. Moreover, the extra currents flowing to *L* oppose the prolongation due to static induction and expedite the working of the circuit itself. The amount of current required to neutralize the prolongation due to static charge is

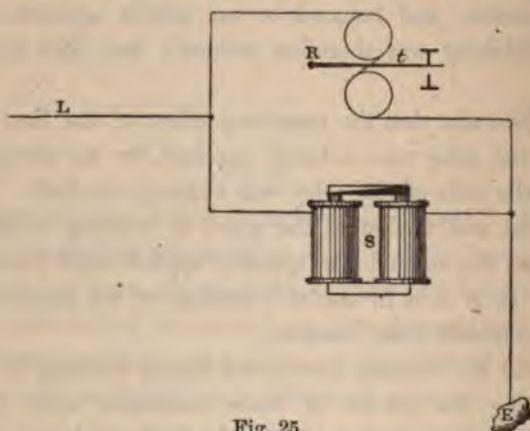

Fig. 25.

easily regulated by the methods described in (§ G 2). This mode of working has been largely introduced in India with great success, where a wedge-shaped armature sliding on or off the poles is used to vary the strength of the extra currents.

6. A system of automatic telegraphy* has been recently introduced in America, which is an improvement upon Bain's punched paper and chemical recorder system that was introduced into this country in the year 1845.

B (fig. 26) is the transmitting, A the receiving, apparatus. P is the punched paper, which directs the sending currents by means of the style *b*. S is an electro-magnetic shunt which sends reverse currents to the line, whose strengths are adjusted by the rheostat R, to neutralise the return currents and clear the line.

* This system is called Edison's, but it is claimed by Mr. Little and others. It would appear, however, that Mr. Edison applied the electro-magnetic shunt to the Bain's recorder, while Mr. Little introduced the condenser to effect a similar object.

C is the receiving apparatus, consisting of a style *c*, resting on chemically-prepared paper *p*, connected up with an adjustable electro-magnetic shunt S^1 , whose extra currents can be varied by a slide *D* so as to meet the varying conditions of the line. By this means marks are so clipped that all tailing-off is prevented and the rate of working is wonderfully increased. Sir William Thomson saw 1,015 words sent in 57 seconds.

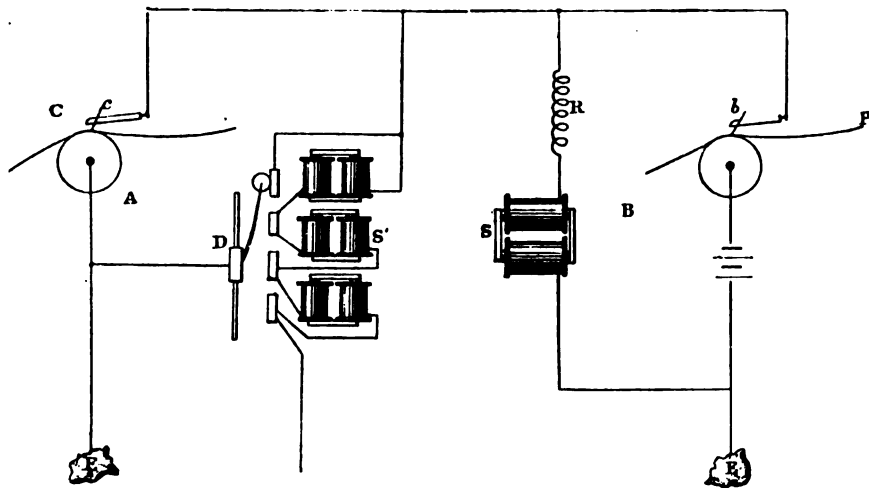

Fig. 26.

The effects of a magnetic shunt have been described in J 2. Blaserna* has shown that the curves formed by extra currents are similar in form to those caused by electrostatic induction, and that their effect as regards time is similar. Hence, as they may be opposite in direction, it is evident that they can be made to neutralise each other.

7. In 1871 it was found that on short circuits it was better to work the Hughes' instrument with the coils joined up in quantity than joined up in series, for by that means not only was the resistance greatly reduced but the induced currents produced by the movements of the armature were rendered comparatively feeble.

The mode and effect of joining up an electro-magnet in

* "Delle Correnti d'Induzione e delle Extra Correnti." Professor Blaserna, Palermo, 1870.

“quantity,” and the behaviour of the currents in such a system, has been shown in experiment III., fig. 11, and in H 6, fig. 16, III.

In such a case each coil practically becomes a shunt to the other, and the resultant extra current in each is small.

This mode of connecting up has been adopted with great success in fast-speed apparatus by Mr. Culley, and the rate of working has been increased thereby from 10 to 20 per cent. This salutary effect is due not only to the almost entire removal of electro-magnetic inertia from the relay, but to the throwing upon the line the extra currents so as to neutralise the effects of static induction.

The extra currents at L, fig. 16, III. are in the reverse direction to the discharge or return currents due to electrostatic induction, and therefore neutralize them and hasten the clearing of the line-wire.

This mode of connecting up magnets is advantageous wherever quick action is desirable, and it was its marked success in an electro-magnetic machine that attracted Mr. Culley's attention. It has been applied with great advantage to the single-stroke bells used for signalling on railways, and doubtless, as its advantage becomes known, it will be generally adopted *

Conclusion.

The introduction and study of the effects of electro-magnetic shunts, and of the influence of electro-magnetic inertia, upon fast-speed apparatus, are thus producing quite a revolution in the construction and mode of connecting-up apparatus, and there is every reason to believe that we are only upon the threshold of improvements which will still further expedite the rate of working upon long lines.

Many of the effects which have been hitherto attributed to residual magnetism are doubtless due to electro-magnetic inertia, and many effects assigned to electrostatic induction are doubtless due to the same cause. An overground wire with a number of electro-magnets in circuit is as much subject to retardation as a

* Interesting papers by Mr. Lacoine, on the same subject, will be found at pp. 215 and 218. He has independently, and very ably, worked out the question.

cable. The discovery of a cause is the first step towards the removal of an effect, and now that we know how to distinguish between the effects of electrostatic induction, electro-magnetic inertia, and residual magnetism, and to comprehend their causes, we may hope to remove, or at any rate materially to diminish, their retarding influence on the speed of signalling.

APPENDIX I.

The ratio of Shunt to Electro-magnet to obtain the maximum effect.

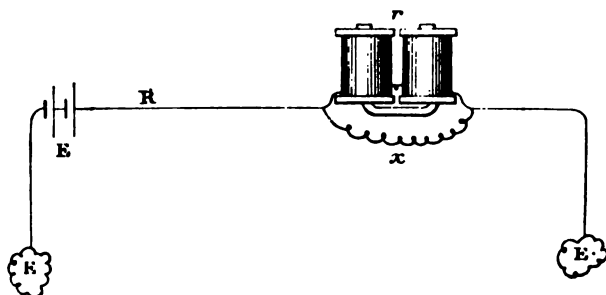

Let C = current flowing out of battery, then

$$C = \frac{E}{R + \frac{rx}{r+x}} = \frac{E(r+x)}{Rr + Rx + rx},$$

and current C_1 flowing through magnet will be

$$C_1 = \frac{E(r+x)}{Rr + Rx + rx} \times \frac{x}{r+x} = \frac{Ex}{Rr + Rx + rx}.$$

Let C_2 be the magneto current produced on the disconnection of the battery. The strength of this current will depend upon the resistance of the circuit through which the magneto current flows, and also upon a constant whose value depends upon the make of the magnet, that is,

$$C_2 = C_1 \frac{k}{x+r} = \frac{Ekx}{(Rr + Rx + rx)(x+r)}.$$

Now at a maximum,

$$\frac{d C_2}{d x} = \frac{1}{[(Rr + Rx + rx)(x+r)]^2} (Ek(Rr + Rx + rx)(x+r)$$

$$- Ekx(2Rr + 2Rx + 2rx + r^2) = 0;$$

hence

$$2Rrx + Rx^2 + rx^2 + Rr^2 + r^2x = 2Rrx + 2Rx^2 + 2rx^2 + r^2x;$$

therefore

$$Rx^2 + rx^2 = Rr^2;$$

and

$$x = \sqrt{\frac{Rr^2}{R+r}} = r \sqrt{\frac{R}{R+r}} = r \sqrt{\frac{1}{1+\frac{r}{R}}}.$$

If R is very large compared with r then we get

$$x = r \sqrt{\frac{1}{1+0}} = r.$$

$$\text{If } r = R \quad x = r \sqrt{\frac{1}{2}}.$$

APPENDIX II.

The relative Extra Current external to the Electro-magnet when the coils are joined up in series and in quantity.

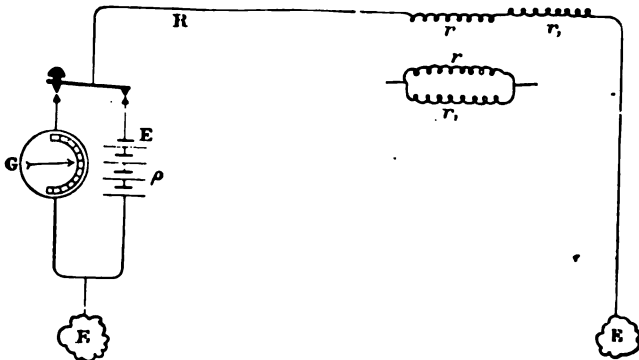

Let $r \rho$ be the resistances of the two coils of the electro-magnet, E an electro-motive force of resistance, and G a galvanometer of resistance G .

First, let the two coils of the electro-magnet be joined up in series. The current flowing out of the battery and through the coils will be

$$C = \frac{E}{\rho + R + 2r}$$

This current in flowing through the coils will induce magnetism in them of an intensity proportional to the length of wire in them, and to a constant k dependent upon the make of the magnet. Now the induced current which will be developed in the coils on the cessation of the charging current will be directly proportional to the intensity of this magnetism. The current developed in *each* coil will be therefore

$$C k r = \frac{E k r}{\rho + R + 2r},$$

and in the two coils

$$\frac{2E k r}{\rho + R + 2r}.$$

When the key is depressed the magneto current is discharged through the galvanometer and its strength will be proportional to the resistance in the circuit, thus :

$$C_1 = \frac{\frac{2E k r}{\rho + R + 2r}}{G + R + 2r} = \frac{2E k r}{(\rho + R + 2r)(G + R + 2r)}.$$

If now the coils be joined up in sets, that is for quantity, then the two coils act as two batteries joined up for quantity, that is, the current discharged through the circuit will be that of one coil only, thus :

Current out of battery is,

$$\frac{E}{\rho + R + \frac{r}{2}} = \frac{2E}{2\rho + 2R + r},$$

and current through each coil,

$$\frac{E}{2\rho + 2R + r},$$

and current from each coil,

$$\frac{E k r}{2\rho + 2R + r},$$

then the current through galvanometer will be,

$$C_2 = \frac{E k r}{G + R + \frac{r}{2}} = \frac{2E k r}{(2\rho + 2R + r)(2G + 2R + r)},$$

$$C_1 : C_2 :: \frac{2E k r}{(\rho + R + 2r)(G + R + 2r)} : \frac{2E k r}{(2\rho + 2R + r)(2G + 2R + r)},$$

or,

$$C_1 : C_2 :: (2\rho + 2R + r)(2G + 2R + r) : (\rho + R + 2r)(G + R + 2r).$$

If r is very small compared with the other resistances then

$$C_1 : C_2 :: 4 : 1;$$

but in this case the magnetic attraction, when the magnets are joined up in sets, is only half what it would be if they were joined up in series. To obtain the same magnetic attraction in the former case the battery power would have to be doubled, and then the ratio of the discharges would be as

$$2 : 1.$$

In an experimental result made to prove the correctness of the theory, the numerical values of the quantities were as follows:

$$r = 250, R = 0, \rho = 820, G = 690.$$

Inserting these values we get—

$$\begin{aligned} C_1 : C_2 &:: (2 \times 820 + 250) (2 \times 690 + 250) : (820 + 500) (690 + 500) \\ &:: 3080700 : 1570800 \\ &:: 30.8 : 15.7 \\ &:: 34 : 17.3. \end{aligned}$$

These exactly corresponded to the deflections obtained on a galvanometer.

[The paper was illustrated by practical experiments, carried out by the author, with the aid of Mr. Latimer Clark's School Galvanometer and the lime light.]

The PRESIDENT: You have anticipated what I was about to propose to you, viz., that we should thank Mr. Preece most heartily for the valuable communication he has brought before us. One does not know which to admire most, his perfect mastery of his subject, for which perhaps we were prepared, or the lucidity of his

exposition of that subject. He has given us an exceedingly clear explanation of the effects of induced currents, and of the various ways in which shunts may be employed to counteract the retarding effects of those currents, and has shown, besides, the way in which shunts may be applied to a variety of important purposes. We had hoped this evening to have commenced a valuable discussion on this subject, but inasmuch as Mr. Preece has occupied in so interesting and profitable a manner the whole of the time allotted to our meeting we are under the necessity of postponing the discussion till the next meeting, which will be held on the 28th inst. It may not occupy the whole evening, and, if not, Mr. Treuenfeld has promised us a paper on "Fire Telegraphs." I have now to ask you to accord your thanks to Mr. Preece for his most valuable paper.

The vote of thanks having been heartily and unanimously accorded,

The following Candidates were balloted for and duly elected:—

FOREIGN MEMBERS :

George T. Helland.
 Frederick von der Pforden.
 Edward Rau.
 Frederick John Reutzch.

MEMBERS :

Richard Anderson.
 Hubert Blanchford.
 Lieut.-Col. William Crossman.
 W. T. Newitt.

ASSOCIATES :

Robert W. Aldis.
 Lieut. A. H. Bagnold.
 S. S. Bailey.
 Walter Betts.
 Corporal Arthur Botham.
 C. M. P. S. Colmache.
 John Hamilton Crilly.
 Charles Cuttries.

William Dieselhorst.
W. Dickinson.
Major A. G. Durnford.
Samuel A. Earle.
Thomas Forster.
M. J. Games.
Alfred Graham.
Henry Seraclens von Graney.
G. A. Green.
T. T. Hockley.
Thomas Isley.
W. J. James.
James Rooney McDonald.
Lieut.-Col. McGregor.
R. J. Needham.
C. Newitt.
Charles John Page.
F. Perry.
Walter C. Ross.
Lewis John Rosse.
R. L. Saunderson.
James Scotland.
James Emery Talbot.
Frederick Squires.
C. Trippe.
John Keogh Webster.
Henry Robert Paine Ward.
E. Weedon.
Lieut. Mortimer D. Whitmore.
A. G. Williams.
W. Woodcock.

STUDENTS :

George L. Davies.
Robert Lewis.

The meeting then adjourned.

The Fifty-fourth Ordinary General Meeting was held on Wednesday, the 28th day of February, 1877, Professor FOSTER, Vice-President, in the Chair.

The CHAIRMAN : I have to announce that in consequence of the important character of Mr. Treuenfeld's paper, the main subject for this evening, and the interest likely to be taken in it, the Council have decided, in the interest of the Society, to postpone the discussion of Mr. Preece's paper till a future meeting, of which timely notice will be given to the Members.

FIRE TELEGRAPHS.

BY R. VON FISCHER-TREUENFELD, F.R.G.S.

Before entering on the subject of this paper I feel the necessity of asking your indulgence, because what I wish to draw your attention to is of a purely practical character and cannot be said to possess anything for which either originality or novelty can be claimed on my part. I hope, however, that what I have to say may be found new to many of the members of this Society, and may in some way help to clear the way for further improvements in Fire Telegraphs.

It has often been a matter of speculation with me why certain inventions seem to be so much more favourably received by one country or department than they are by another.

Looking at the working of different administrations we hardly ever find two endeavouring to reach the same end by exactly the same means. It would at first sight appear rational that the means by which truth is to be attained should always be the same; this is, however, not so, and this fact is strongly illustrated with reference to the subject now before us; Fire Telegraphs having been adopted by some towns as an indispensable means of preventing destructive fires, while other towns, with exactly the same end in view, have not adopted them.

In England Automatic Fire Telegraphs are still a thing of the future. I trust the circumstance of their not having yet been adopted here will not for a moment be considered as an argument against them. I, for my part, firmly believe that they have here before

them as wide a field and as successful a life as that which they now enjoy on the Continent and in the United States.

The primary object of Automatic Fire Telegraphs is to reduce to a minimum the time between the discovery of a fire and the appearance of the brigade on the spot. It may safely be said that in general the chances of a fire becoming "serious" increase at least with the square of the time which elapses between the outbreak of the fire and the arrival of the brigade. Could the latter be on the spot immediately after the outbreak, the possibility of a "serious fire" could hardly exist. On the other hand, by a delay in the arrival of the brigade, the rapid increase of heat, and consequent formation of combustible gases, cause the fire, at first comparatively insignificant, soon to assume serious proportions.

A thoroughly well-trained brigade, with perfect equipment and abundant water-supply at hand, may in many cases make up by their efficiency for what has been lost by delay in their arrival; but even with all these favourable circumstances a successful result is imperilled. We are somehow led to see an analogy between their action and that of a medical man, who gives his patient a good opportunity of becoming seriously unwell, previous to paying any attention to him, so that in case of the patient's recovery he may boast of his skill in curing.

A fire brigade, however well equipped and organised, cannot reach the best results unless assisted by a telegraph which possesses the means of reducing delay to a minimum.

This is a maxim to which all experienced firemen subscribe. On this point I quote the opinions of the two following gentlemen from many of a similar nature which have reached me with reference to this part of the question. Mr. Schumann, chief of the Bremen brigade, says, "Fires, like enemies, are more easily attacked and beaten in their advanced lines than in mass." And again, Mr. George A. Reilly, Superintendent of the Belfast Fire Brigade, very justly says, "As we have no fire-telegraph stations, and the fire alarms are brought by police or civilians using hackney cars, I need hardly remark that all fires in business concerns are sure to be serious if not checked at an early stage. Fires in our factories and linen warehouses, if not subdued within the first half-hour, *are sure to be serious.*"

Mr. Robert Walker, Police Superintendent of the second district of the London Metropolis, in his annual report for the year 1875, urges on the Commissioner an extension of the telegraph system over the suburbs of London along the great lines of road, and says: "I would respectfully urge that it is as important to householders in the outskirts for the police to have means at their command for the speedy circulation of information in respect of crime, fire, or the like, as to those in the more favoured inner districts where telegraphic connection is close" "The telegraph instrument cannot be too fully appreciated for the purposes of police, and its value is really not known until it is at hand"

The principle on which good Fire Telegraphs are based is that of establishing in sufficient numbers, and in easily accessible places, suitable apparatus by which the outbreak of a fire may be communicated by any person to the nearest fire-engine and police stations, or to a central station from where immediate orders are issued.

Various methods may be adopted in order to obtain this result, but that which experience shows to be the most satisfactory, and which has best stood the test of time thus far, is the automatic system in use at many towns where a system of Fire Telegraphs has been established.

By means of the automatic apparatus a certain sign may be telegraphed to the central stations indicating the street and district from which the alarm of fire was sent.

It is evident that by sufficient distribution of this automatic apparatus over a town the time required for the dispatch of the brigade must be considerably shortened, thus allowing the fire to be attacked when in its infancy, and when the smoke and other obstacles likely to impede the action of the brigade are less serious. That this must be so not only stands to reason but has been proved to be the case, as may be shown by comparison of a few statistical results.

Let us first see how London, possessing no system of automatic fire-telegraphs, stands with regard to the number of slight and serious fires.

The Select Committee appointed by the House of Commons to inquire into the means of protecting life and property in the

Metropolis from fire, met in April 1876, when Captain Shaw, Chief of the Metropolitan Fire Brigade, gave the following data:—

Year.	Small Fires.	Great Fires.	Total.	Per-centage of Great Fires.
1866	1,012	323	1,335	24·2
1867	1,152	245	1,397	17·6
1868	1,433	235	1,668	14·1
1869	1,373	199	1,572	12·6
1870	1,670	276	1,946	14·2
1871	1,635	207	1,842	11·2
1872	1,374	170	1,544	11·
1873	1,382	166	1,548	10·7
1874	1,419	154	1,573	9·8
1875	1,366	153	1,519	10·

This table, although presenting the highly satisfactory result that our Metropolitan Fire Brigade has succeeded in reducing the number of "serious fires" within the last ten years by more than fifty per cent. in spite of the large increase of population, nevertheless betrays the alarming fact that ten per cent. of our Metropolitan fires still are serious ones. This proportion is by far too high, and I will show you by comparison with other towns provided with the automatic system of Fire Telegraphs, but otherwise not so efficiently served, that this high per-centage of serious fires can and ought to be reduced.

In his report, Captain Shaw, Chief of the Metropolitan Brigade, suggested various improvements, one of which was to considerably increase the force. He proposed to have 931 firemen, 330 fire-engines, 200 fire-escapes, and 169 fire-stations, in place of those now at his disposal.

Bearing in mind the high results attained by the employment of the automatic system of Fire Telegraphy, I venture to believe that Captain Shaw's hands could be strengthened in providing for our safety against fire by the help of a system of Fire Telegraphs with

Annunciators, even more than by any increase of the force that might be proposed. There is, besides, the additional argument on the score of economy. London is served by a brigade with a well-earned reputation for ability and bravery, and the water-supply is most efficient.* I have therefore purposely chosen it for comparison, so that my arguments may apply more strongly to other towns less efficiently served.

Let us next compare the per-centage of serious fires in the town of Berlin, where the Automatic Fire Telegraph system is in operation. This town has not by any means been picked out as a favourable specimen, but is taken at random, and will be followed further on by others, with an equally satisfactory result.

Berlin, which is certainly not supplied so well, either with engines or water as London, gives the following statistics:—

Years.	Slight Fires.	Great Fires.	Total.	Per-centage of Great Fires.
1873	873	28	901	3.11
1874	906	26	932	2.79
1875	983	26	1,009	2.57

From this table you will see that the “great fires” are only 2.82 per cent. In this list, by a “great” fire is understood a fire for the extinction of which more than two engines or reels were required.

I will now lay before you the chief outlines of the Automatic Fire Telegraph system, and, as there are in each town slight modifications of the general plan, I shall explain the systems as actually adopted in some of the towns, selecting such as may be considered types of the system.

* From the Metropolitan Water Companies' Report of September 1876, sec. 12:—The number of miles of streets which contain mains constantly charged, and upon which hydrants for fire purposes could at once be fixed, gives a total length of 667½ miles. The total number of hydrants erected is at present 4,211.

HAMBURG FIRE TELEGRAPH.

From the plan before you you will see that Hamburg possesses two Central Stations F and P; F is the Central Fire Brigade Station, and P the Central Police Station. Both stations are connected to seven district lines, which run radially from these centres to the suburbs, each line being connected with a number of

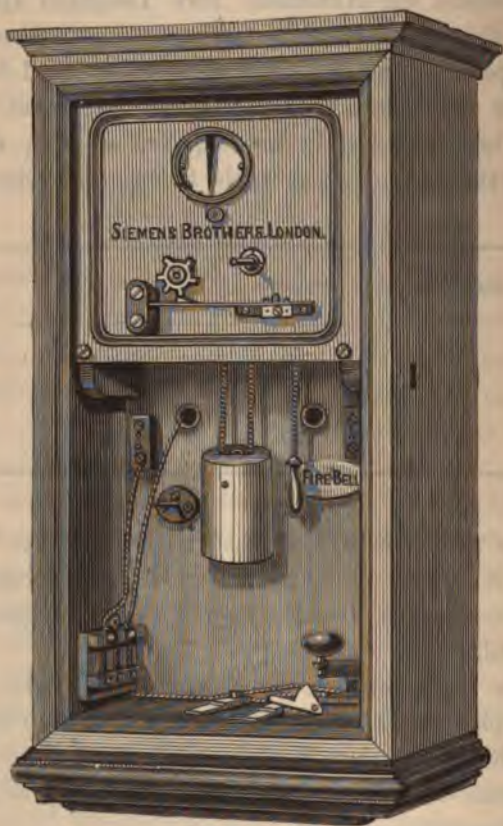

Fig. 1.

fire brigade and police stations, as well as automatic Fire Annunciators.

The chief object of these seven lines, with their annunciators, and fire brigade and police stations, is to send immediate notice to

ICE TELEGRAPHS.

- *Central Station.*
- *Fire Speaking Station.*
- *Fire Annunciator.*
- ⊕ *Police Speaking Station.*
- *Underground Cable.*
- - - *Overground Line.*

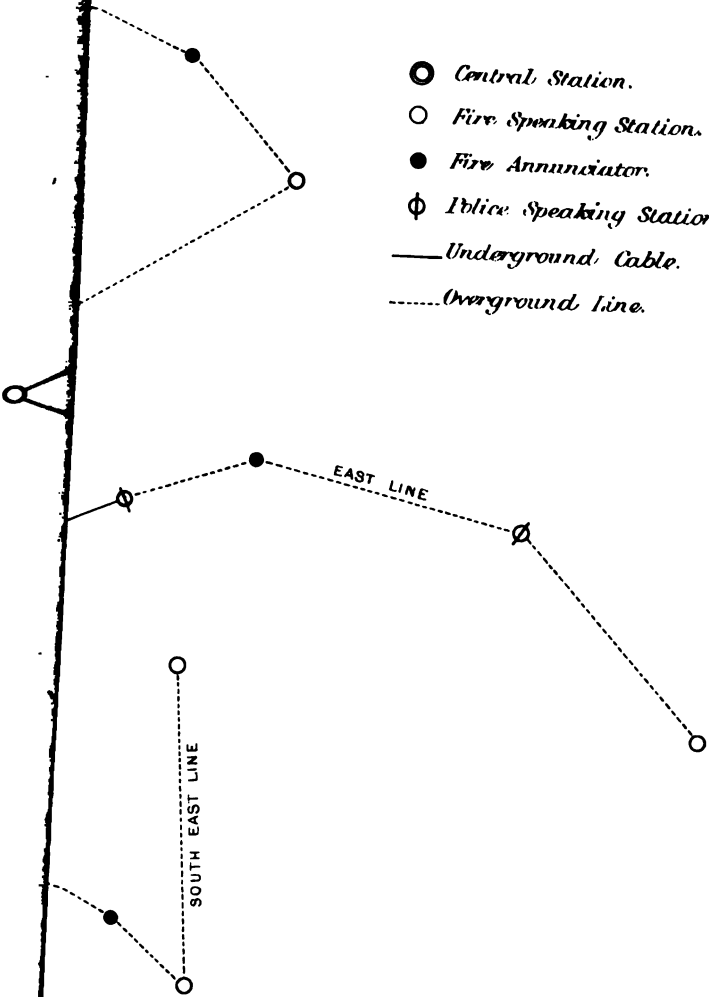

the brigade stations from the locality wherein the fire is first discovered. Besides this, telegraphic communication can be maintained between the different stations (as well as from the annunciators to the central stations), so that the required assistance may be properly disposed of. In this system it will be observed that all fires are first announced to the central station, and that all arrangements for the suppression of every fire are made from this central station, which thus regulates and controls the entire system.

The Automatic Fire Annunciator is a very simple mechanical contrivance, introduced into the telegraph line, through which circulates a permanent current from a battery established at the central station. The Annunciator, when brought into action, breaks the circuit and thus sends a certain signal to the central station. The breaking of the circuit is caused by the rotation of a contact-wheel, the periphery of which is so shaped that the contact-breaking corresponds to a certain Morse signal, and each signal to a certain district or street of the town. I have brought here with me two of these Annunciators, and have them connected with two Morse, one representing a central station and the other an intermediate receiving station. You will perceive that the working of the system is simple, reliable, and intelligible to anyone. The Annunciator is protected by a glass front, and is placed at street corners, in guard or railway stations, or in pillars situated in a prominent position, and where there is little likelihood of its being wilfully damaged. On the discovery of a fire all that has to be done is to run to the nearest Annunciator-box, open or break the protecting glass, and pull the handle. The contact-wheel then rotates, and the letter corresponding to the Annunciator is transmitted several times in succession to the central fire brigade station, whence orders are telegraphed to the various engine and police stations.

From the diagram you may see the entire system with the position of its various stations. In a town of the dimensions of Hamburg it would not be sufficient to rely solely on having the stations connected only with Annunciators. It is needful to have a number of speaking stations at suitable distances from each other, with Annunciators between each: this is actually the case

in the town which I have selected. There are, besides the two central stations, 47 Morse stations and 53 automatic Annunciators, that is to say, 102 places from which the outbreak of a fire can be announced by telegraph.

Both Annunciators and Morse are connected to the same line, the former being situated at prominent places as previously mentioned, the latter at fire brigade and police stations.

The apparatus employed in the stations at Hamburg are Morse Inkwriters, with the usual complement of details. These are placed on a table, and so arranged with spring contacts that any

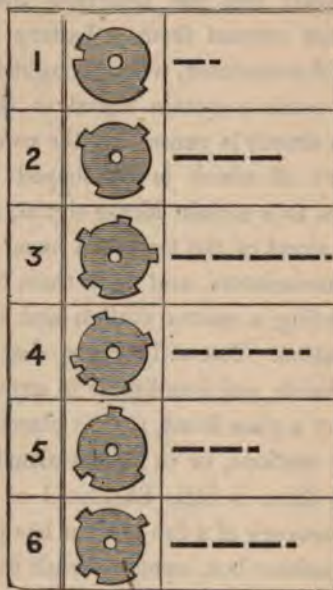

Fig. 2.

instrument may, without the use of tools, be removed from or fixed to the table without interfering with the line circuit.

Each central station has seven complete self-starting Morse Recorders, one for each telegraph-division line.

The Morse Recorder is undoubtedly much more suitable for fire telegraph stations than the alphabetical dial instruments. The latter, besides keeping no record of the signals, are much more liable to get out of order when several are connected up in the

same circuit. In addition to this, precious time may be wasted when every moment is of value in setting matters right when the synchronism between the different instruments has been disturbed. Experience has shown that the oft-quoted argument against the Morse, that it is so much more difficult to acquire a knowledge of its working than in the case of the alphabetical instrument, is without foundation.

From the batteries, consisting of 350 Meidinger elements, 50 for each district line, a permanent current flows through the lines, all signals being made by breaking the circuit. This system has the great advantage of indicating at once when any break in the connections or lines takes place, thus offering the best possible guarantee against failure in telegraphic communication in the cases of sudden and unforeseen emergencies.

HAMBURG FIRE TELEGRAPH.

Radial District Lines.	Telegraph Lines.		Stations with Morse Recorders.	Automatic Fire Annunciators.
	Underground cable.	Overground wire.		
1. Southern line	21,950 feet	...	6	7
2. South-western line ...	25,100 ,,	...	11	4
3. North-western line ...	26,450 ,,	15,400 feet	10	5
4. North line	12,600 ,,	28,400 ,,	7	8
5. North-eastern line ...	16,800 ,,	31,700 ,,	10	10
6. Eastern line	20,800 ,,	22,300 ,,	8	10
7. South-eastern	20,150 ,,	12,200 ,,	8	9 .
Total	143,850 ,,	110,000 ,,	60*	53

The seven radial district lines all unite at the central fire brigade station to which all fire alarms are first sent, and from

* The actual number of speaking stations is 50; in the above table the two central stations appear seven times, once on each of the seven district lines. Both under and overground wires have lately been augmented, and there are now 151,631 feet cable and 126,641 feet overhead line.

which the requisite orders are immediately issued to the stations in the vicinity of the fire. By the different stations being thus connected together every facility is afforded to each station to give its help to the others as circumstances may require.

The telegraph lines are preferably underground, as greater security against interruptions is thereby afforded. In the centre of towns underground cables should be exclusively employed; overground wires, if employed at all, should be erected only in the suburbs, where from natural causes there is less probability of an outbreak of fire and of line interruptions; but even in these parts it is of the utmost importance to have the lines of the very best material in order to shut out even the bare chance of failure.

These principles have been fully carried out in the Hamburg Fire Telegraphs, where there are employed 151,631 feet of underground cable and 126,641 feet of overground line—the latter in the suburbs of the town only. The cable is a very strong one, being a three-strand copper conductor, insulated with gutta-percha, covered with hemp and sheathed with 13 galvanised iron wires. Between the two central stations (a distance of 6,300 feet) runs a seven-cored gutta-percha cable covered with hemp and 19 galvanised iron wires.

All cables are laid at a depth of from four to five feet, and at specially dangerous points the cable is further protected by iron pipes.

The overground wires are of the best galvanised iron, 4 millimètres in diameter (B. W. G. No. 8), erected chiefly on tubular wrought-iron poles, with cast-iron sockets and wrought-iron buckle-plates, 25 feet long, and placed apart at distances between 200 and 250 feet. The insulators are the porcelain bell-type, with cast-iron hoods as a protection from wilful damage.

The working of the system is as follows: All stations except the central have their Morse instruments cut out and only a loud sounding alarum in circuit. A signal sent by any of the Annunciators or Morse stations is recorded at the central station on a self-starting Morse, attached to that line. The central station after receiving this signal sends by means of a magneto-inductor the fire alarm to all the stations of the district, or, if need be, to all

the stations of the seven districts simultaneously, by means of a commutator fixed for this purpose. The operator at each Morse station, by a slight pressure of his foot on a lever, brings his instrument into circuit, and by this means each station is ready to receive orders from the central station, to which the exact position of the fire has been previously made known. The arrangement is such that when the operator takes up his position at the table the instrument is brought into circuit by means of the lever contact-maker. As soon as he departs from this position the instrument is cut out of circuit. In this way there is no chance of delay or failure from forgetfulness on the part of the operator.

The alarm signal is instantly followed by definite orders to the fire brigade and police stations nearest the fire. These, having been already roused by the alarm signal received from the central station, are thus in a position to start the moment instructions are received.

The entire system has been erected at a cost of only £8,028, and is maintained at a yearly expenditure of £80.

Having thus shown the arrangements and working of the radial system as in operation at Hamburg, I will now draw your attention to the circular system of Fire Telegraphs, taking that in use at Amsterdam as an example.

A diagram showing the various lines is subjoined.

Except in the suburbs, all the lines are cables, with a three-strand copper conductor, insulated with gutta-percha, covered with tarred jute and sheathed with 12 galvanised iron wires. The dotted lines in the plan represent the over-ground lines, which were adopted in the suburbs in preference to cables, owing to the continued extension of the streets.

The town is divided into three main circles (not including the suburban circle), the offices in each of which are in communication with the central station; they are represented in the diagram by thick lines. Only fire brigade and police stations are in these main circles, and they are so connected that the police stations are situated in one-half and the fire brigade stations in the other half of the circles. By this arrangement the two may be disconnected from each other, and enabled to communicate independently with

their own central office. To effect this there is a permanent earth-connection at the junction of the fire brigade and police stations, and by establishing another earth at the central station the fire brigade and police stations are separated from each other at will, and in independent communication with the central station.

To each of the three main circuits a number of divisional circuits is attached, having their centres in one of the fire-brigade stations.

These divisional circles contain, as a rule, only automatic fire-annunciators, although, as will be gathered from the diagram, this rule is not altogether absolute.

The entire arrangement is given in the following table, from which it may be seen that there are 50 Morse apparatus and 135 Annunciators in use:—

AMSTERDAM FIRE TELEGRAPHS.

Main Circle.	Divisional Circles.	Morse Apparatus.	Automatic Fire Annunciator.	Remarks.
Eastern section	5 circles	15	40	There are, besides the central fire brigade station and the central police station, nine fire brigade and six police stations
Southern section	3 circles	15	31	There are also a few short lines connecting the houses of the two commandants with the central fire brigade station, the houses of the chiefs of police with a police station, the burgomaster with a fire brigade station, all worked by magneto-dial instruments. There is, besides, a short line to a gong placed close to the fire-boats.
Western section	4 circles	15	38	
Suburban circle	1 circle	5	26	
Total	13	50	135	

Besides these, a few magneto-dial instruments in connection with the houses of a few high officials are joined up on special lines.

CE TELEGRAPHS.

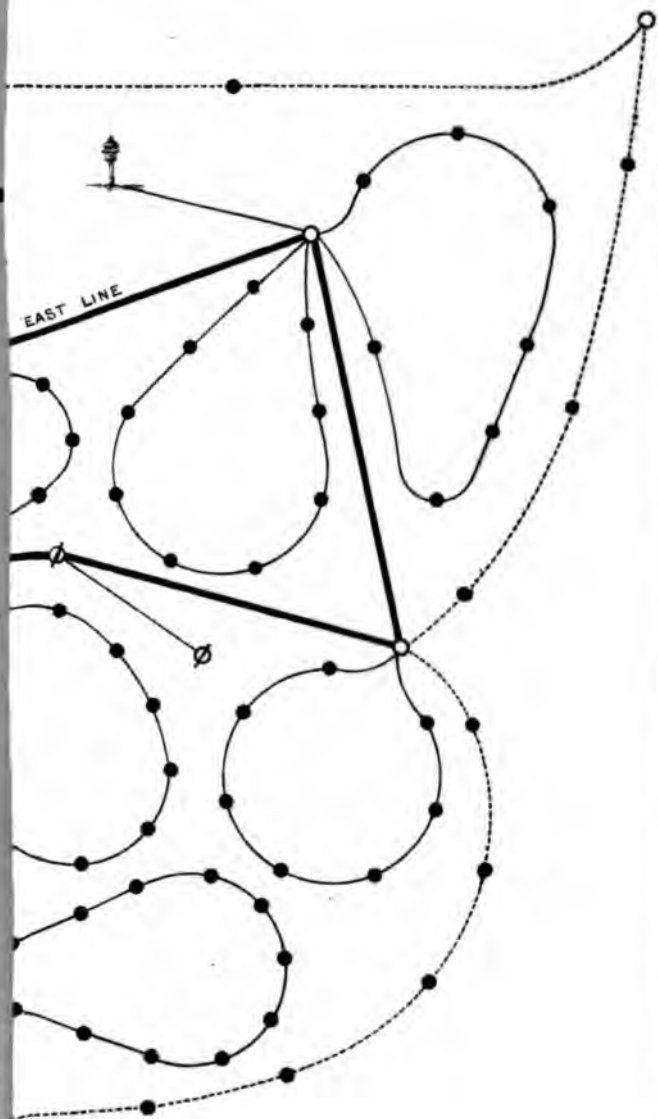



In all there are 159 places from which Fire-alarms may be given by telegraph.

All the lines are worked on the closed-circuit system, the batteries, of the Meidinger form, being at the central station.

The automatic Annunciators have, besides the clockwork required for the movement of the contact-wheel, a Morse key (fig. 1), a galvanoscope, and a lightning-protector. By means of the key messages can be sent to the station of the division if required.

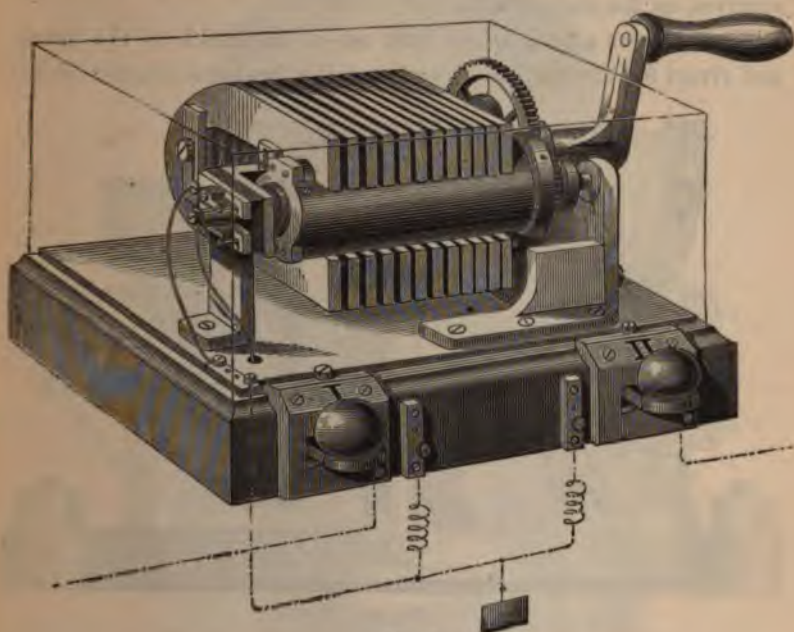

Fig. 3.

The Morse apparatus in the stations is fixed in the same way as in the Hamburg system.

In the central station is a magneto inductor, by which the alarms of all stations may be rung, and by an agreed combination of bell-signals either all or any single station may be called by the central station.

The working of the system is similar to that in use at Hamburg. All stations, except the central, have their Morse's "out" and their inductor bells "in." As soon as the central station receives a

fire signal the alarm-call is given by the magneto-inductor, and each station puts its Morse in circuit in the manner already described, to receive orders from the central station. The latter is provided with a special commutator by which any of the stations may be individually called by bell, or all sections simultaneously called together, and a message despatched to all at the same time.

The magneto-inductor is shown in fig. 3. This inductor sends a series of alternating currents, giving the fire alarm, which is received on the station bells.

Fig. 5 shows a gong which is in use on the banks of the canals and rivers for the purpose of warning the fire-boats moored in the

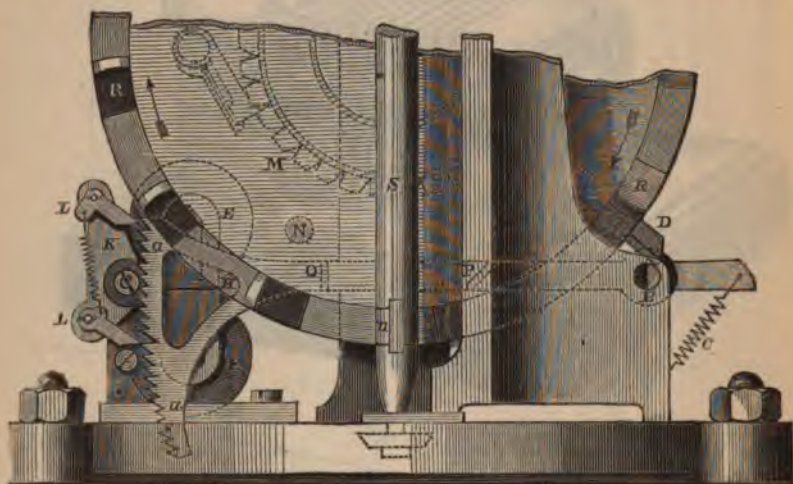

Fig. 4.

channel; and fig. 4 shows the detailed electrical arrangement which arrests and frees the spindle acting upon the hammer of the gong.

I will now briefly describe a third type of fire-telegraphs similar to the first in being radial, but differing in having branches from the sectional lines. It is the system adopted in Frankfort-on-the-Main, and carried out by its engineer, Mr. C. Vogel, a member of our Society, to a perfection which deserves no small praise.

From the plan you will see that there are eight main and 32 branch circuits; the former are indicated by continuous lines, and connect stations fitted with either annunciators or speaking apparatus;

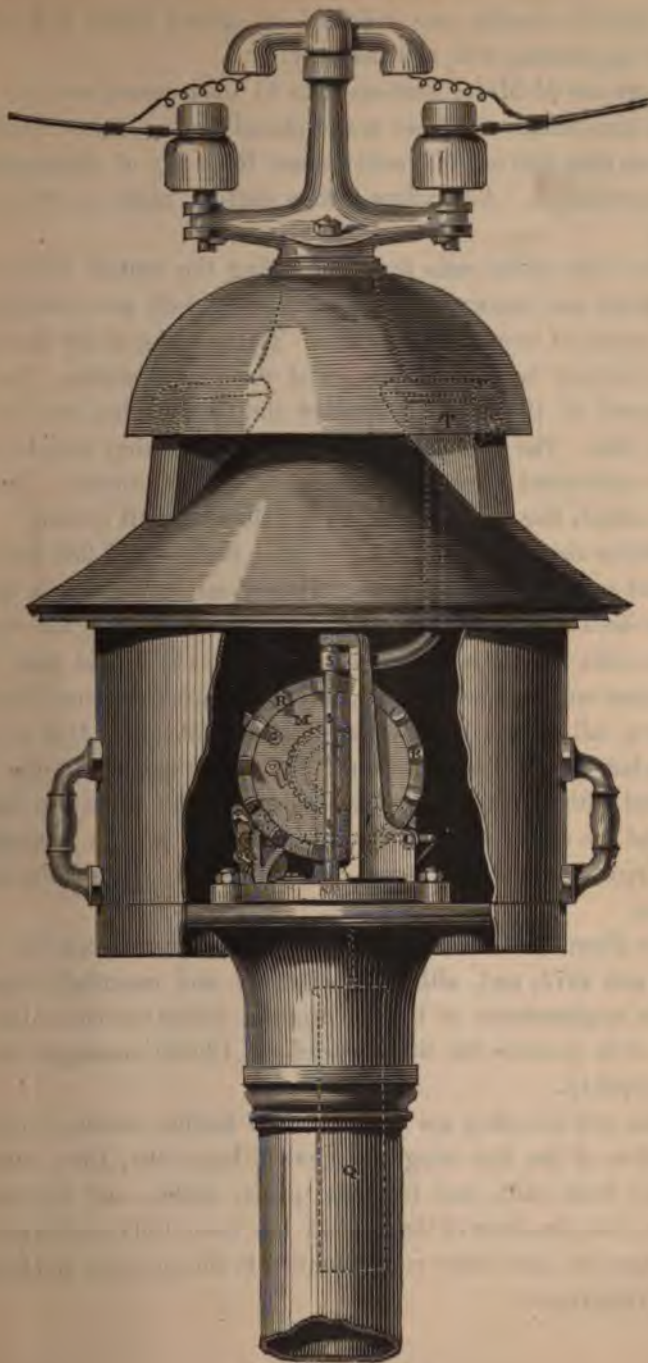

Fig. 5.

the branch circuits are indicated by dotted lines, and contain receiving stations with alarms only.

There are 25 Morse stations with 31 instruments and 50 automatic annunciators. These are so placed that no house in the town is more than 500 or 600 yards distant from any of these points of communication. All stations have a staff on night as well as day duty.

The whole of the main lines connecting the central station with the Morse and annunciators, in all 95,234 feet, are underground, and consist of iron-sheathed cables. The batteries of the Meidinger type—of very low resistance—are at the central station; they are composed of 196 elements divided into 8 batteries, one for each main line. The elements are so arranged that they may be added to, or subtracted from, without interrupting the circuit. The lines are worked, like the previous, on the closed circuit system.

Besides the underground radial lines there are 55,930 feet over-ground secondary branch lines. These lines are fitted with electric house-bells only, which are connected with the fire-brigade stations. These bells are placed in the houses of the chiefs and men of the volunteer and regular brigades, and at the police stations; they also serve to call extra help in cases of serious danger. One of these secondary branch lines in circuit No. 4, marked *a b* in the plan, is fitted with a magneto-electric indicator at *a*; when the latter is worked the annunciator at *b* is set in motion, and by interrupting the circuit transmits the signal in the usual way towards the central station.

The Frankfort Fire Telegraph was erected between the years 1873 and 1875, and, although originally and essentially intended for the requirements of the fire brigade, it also served in the first year of its erection for the despatch of 12,000 messages for the municipality.

Time will not allow me to enter into further details of the construction of the fire telegraph; but I hope that, from what has already been said, and from the plans, tables, and instruments shown, the character of the system has been fully understood. I will therefore next draw your attention to the rules for working the Fire Telegraphs.

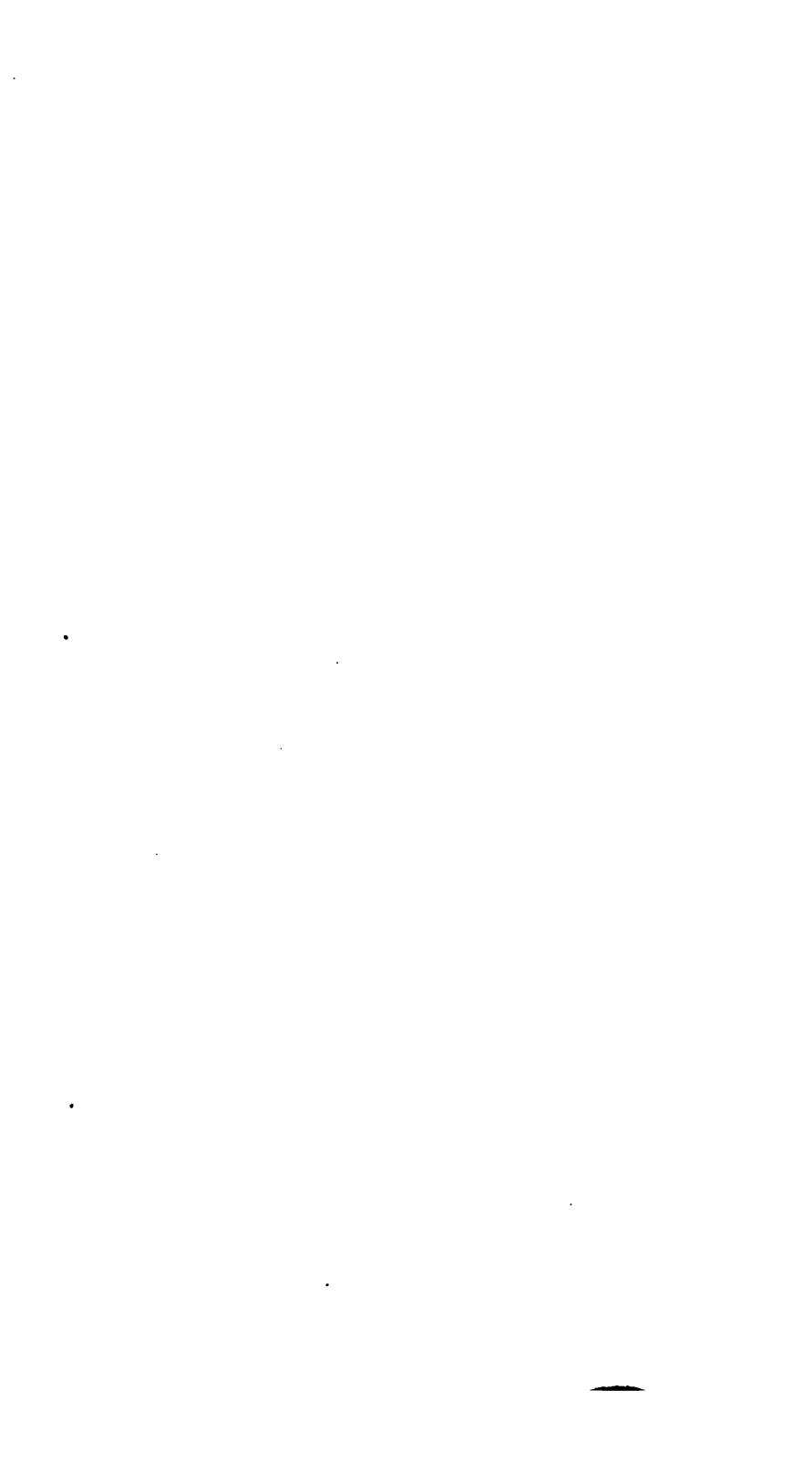

PLAN OF FRANKF

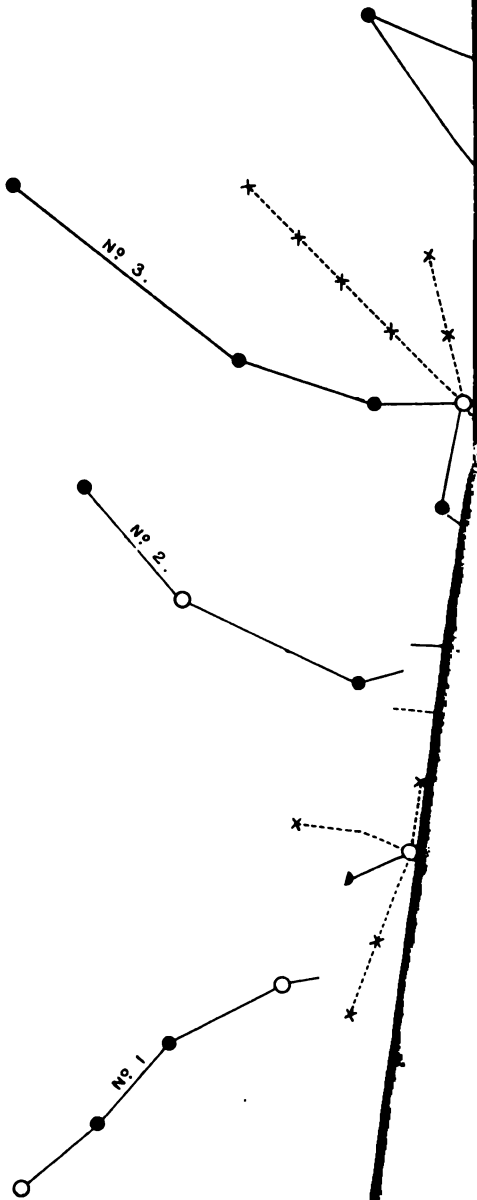

FRANKFORT-ON-THE-MAIN FIRE TELEGRAPHS.

Lines.	Length in feet.	Speaking Stations (Morse).	Automatic Annunciators.	Secondary Annunciators.	Bell Stations.	Remarks.
MAIN LINE No. 1.	16,988	10	16			<p>All bell stations are worked by alternating currents with magneto-inductors.</p> <p>The eight main lines are joined at central station into four pairs, each pair with one Morse as intermediate at the central station.</p> <p>There are 25 Morse stations and 50 annunciators, in all 75 points from which a fire can be announced. The annunciator when set in motion sends its signal 12 times to the Morse central station apparatus.</p>
" 2.	11,503					
" 3.	13,792	7	13			
" 4.	11,713					
" 5.	11,464	2	8			
" 6.	4,313					
" 7.	8,098	4	12			
" 8.	17,413					
BRANCH LINES:						
1 from Central Station to Chief of the Brigade	1,184	2	—	—	2	
8 to Chief Constables	15,035	—	—	—	22	
2 to Chief Standing Brigade	3,854	—	—	—	3	
20 to Chief Volunteer Brigade	33,784	—	—	—	33	
1 for Secondary Annunciator	2,073	—	—	1	—	
	151,164	25	49	1	60	

As previously shown, all Morse apparatus at the speaking stations, except the central, are out of circuit, while the alarm bells are in. The operator presses a lever underneath the apparatus with his foot, thereby cutting the bells "out" and putting the Morse "in." A galvanoscope is always "in."

It is strictly forbidden to bring the Morse into circuit unless called by the bell-signal, or when the station has to send a message.

The Morse apparatus at the central station are always "in;" they are self-starting, and provided with bells for indicating the commencement of a message.

All calls from annunciators and stations arrive at the central station. The latter calls the stations in that section of the line by means of a magneto inductor. To each station corresponds a certain bell-signal, viz., a combination of short and long bell calls, by which means the central station is enabled to call any given station. The bells are in all cases of what is known as the "chattering" type.

Direct correspondence between stations on the same line is admissible, but between stations on different sectional lines messages must be transmitted through the central station.

Messages for the stations of the same line are given at the central station with an ordinary Morse key. Simultaneous messages for the stations of two or all the lines are given with a universal key.

Urgent messages, such as a fire alarm, are alone allowed to break in on any correspondence. When they do break in the corresponding stations give way at once. There is no mistaking the annunciator-signal, both on account of the regularity with which it is sent and the number of times that it is repeated—no less than twelve times.

To avoid confusion which might take place when an annunciator breaks in on two stations corresponding, both stations keep their Morses in circuit, so that when signals become confused the stations cease speaking and the annunciator alarm is received. The interrupted correspondence can be renewed only on permission from the central station.

When an alarm is received from an annunciator, the receiving central station acknowledges by sending currents so as to deflect the galvanoscope attached to each annunciator three times, and the annunciator is worked until this acknowledgment is received.

So much with regard to the working of the Automatic Fire Telegraph system, which since its first introduction into Berlin in 1849 has become little short of a necessity to all largely-populated towns.

The North Americans, with their well-known ready perception and adoption of all things of public utility, have long recognised the importance of Fire Telegraphs, and now use them on a very extensive scale.

The city of Boston, in 1851, was the first to make the experiment, and from that day, says an American report, "Electricity has kept watch over the lives and property of millions in the principal cities of the United States and British provinces."

The *modus operandi* of the American Fire Telegraphs is similar to those above described, with perhaps one difference. In some towns an automatic arrangement is in operation at a central point. When an annunciator calls, the signal passes through that central place and is received by the entire fire department direct from the annunciator itself. By the use of this arrangement there is no possible delay in the transmission of alarms, the whole of the fire department being reached instantly by the party giving an alarm, without any intervention whatever.

It has been calculated that with the regular central station system in operation 40 to 60 seconds elapse between the time of putting the annunciator in operation and the time when the fire department receives definite alarm. Using the automatic arrangement at a central point there is an average gain of 30 to 45 seconds; however, this latter system misses the advantage of having all orders and dispositions coming from a central office, which remains the head-quarters during the entire operations of extinguishing the fire.

The advantages resulting from a system of Automatic Fire Telegraphy have proved of as great importance in America as in Europe, both with regard to the decrease of serious fires and

insurance salvage. This is fully borne out by an article on "The San Francisco Fire Department," which appeared in "The Times" of 17th August of last year, in which the following passage occurs:—

"More attention is given in America to the improvements and the perfecting of means and appliances necessary for dealing with fires than has yet been generally paid to the subject in England. In a city built of such readily inflammable materials, and visited daily by such high winds as San Francisco is during the rainless summer season, it is of the first importance that a fire should be quenched in its birth. Everything depends on the use made of the first ten minutes after the fire begins, so within a short distance of every block of houses is a telegraphic fire-alarm box, painted red, and affixed to the side of some building or a lamp-post. . . . Many fires have thus been put out by one man of the fire patrol within five minutes of the telegraphing of the alarm by the ordinary district telegraph, which has a connection with their engine-house."

The best evidence, however, of the great value of the Fire Telegraph to Americans is to be found in the fact that it is now in actual operation in 79 cities of the United States and Canada, and in process of construction in several others, while in no single instance has its use ever been abandoned or even temporarily given up.

In the following tables (pages 22 to 33) as full particulars as I have been able to gather of the systems of Fire Telegraphs in some of the principal towns in England, Germany, America, Belgium, and Holland, are given, and added to these are the respective percentages of serious fires.

From these tables I will endeavour to draw some general conclusions; at the same time I am well aware that a comparison of the "serious fires" in the various towns and countries can hardly be made with fairness unless we take into account many other circumstances which have a direct bearing on not only the number of fires but also the percentage of serious ones, and unless we have agreed to a fixed standard unit of what may be called a "serious fire."

In comparing the above tables we must take into consideration that the "absolute security" against fires depends upon *five* main factors; viz., 1st. The construction of buildings and the materials employed. 2nd. The water supply, pressure, and number of hydrants. 3rd. The efficiency of the brigade. 4th. The equipment of the brigade and means for a quick transport of men and apparatus. 5th. The means of giving the alarm, whether by telegraphs, acoustic signals, rockets, &c.

Only towns where these five factors are brought to the highest perfection can approach an "absolute security" against fires; otherwise there can only be a "relative security," which varies in proportion to the greater or less perfection of these factors. In this paper we have only to deal with the fifth item, viz., to show the influence which a well-organised, quickly-acting, and reliable telegraphic fire-alarm exercises towards attaining the desired security against fires. We certainly have to bear in mind that it is not the telegraphic alarm alone which checks the high per-centage of serious fires, but that there are four other factors, of perhaps equal value, and this explains no doubt, to a very great extent, the irregularity in the results of serious fires, as shown in the tables which I have compiled. From these we see that some towns with imperfect telegraphic arrangements give a lower per-centage of serious fires than other towns in which an almost perfect system of Fire Telegraphs exists. This is however only exceptionally the case, and we shall always find that efficiency of the brigade, abundance of water supply, solidity in the construction of buildings, or a judicious choice of fire-proof materials, are the reasons for these apparently contradictory results.

For "absolute security" the highest perfection of these five conditions is required, and therefore these tables can only be considered as demonstrating the results of one of the conditions; they go to prove that where Fire Telegraphs are in operation much better results are obtained than where they are not in operation.

There is yet to be considered the other difficulty in the way of a true comparison of the results in the per-centages of serious fires, viz., the want of a standard unit to determine a "serious fire." My classification is, as far as possible, based upon the definition

TABLE I.
GENERAL ARRANGEMENT AND STATISTICS OF FIRE TELEGRAPHS.

Town.	Population.	Telegraph Lines.			Speaking Stations.		Bell Alarm Stations.	Annunciator.	Fires.			Data received from	Remarks.	
		Circuits.	Feet underground.	Feet over-ground.	Morse.	Dial.			Year.	Num-ber.	Serious.			Per cent serious.
Frankfort-on-the-Main .	103,136	8 main 32 branch	95,234	55,930	25	...	60	50	9th May, 1875, to 31st October, 1876	140	7	5.00	Telegraph engineer of brigade, J. Vogel, and chief of brigade, Assmann	Massive buildings; there are 1,274 hydrants, with 4-atmosphere pressure. The fire telegraph was opened on the 9th of May, 1875.
Amsterdam .	290,000	4 main, 13 branch	233,040	65,600	17	7	1	135	1875 to July, 1876	932	26	2.79	Chief of brigade, P. Steenkamp	The fire telegraph was opened on the 15th August, 1874. In 1875 the number of messages forwarded reached 57,000, and in 1876 till the 15th December, 74,210.
Berlin .	980,000	12	738,000	45,920	17	90	...	110	1873 to 1st January, 1876	2,842	80	2.82	Chief of brigade, Captain Witte	The speaking stations are worked by officers belonging to the Police and by fire brigade men. 1,992 hydrants.
Stettin .	81,072	2	17,056	37,064	5*	...	2	21	1865 to 1st January, 1876	663	28	4.17	Chief of brigade, Bock	The telegraph has been in operation since the 1st of January, 1865; it is worked with contact-making currents and not with the permanent current system as mostly in use for fire telegraphs. * Two complete, three with key, galvanoscope, and bell only.

All lines in town are underground, only suburban lines are overhead. The comparatively high per-centage of serious fires is due to the exceedingly narrow-built and over-populated streets, the town being closed in by fortifications.

There are 2 central stations: 1st central brigade station with 7 self-starting Morse and one universal key; 2nd central police station with 7 self-starting Morse.

Both circles are connected at one point by an automatic commutator (similar to the American automatic central system), and the call from any annunciator is therefore transmitted simultaneously and directly to all the bell alarm stations, thus giving to each of the fire brigade stations and barracks a succession of 6 audible signals, denoting the street from which the call is sent.

1,144 hydrants.

City	Population	Wires	Radial	Circuits	Length	Area	Population	Length	Area	Chief of brigade					
Magdeburg	85,000	3	6	radial	49,670	48,512	12	...	1	51	1874 to 1st January, 1876	186	13	6-99	Chief of brigade, Dietrich
Hamburg	339,400	7	radial	151,631	126,641	50	52	52	1873 to 1st January, 1876	2,029	36	1-77	Chief of brigade, Kipping
Aix-la-Chapelle	80,000	2	circuits	...	78,720	2	27	50	...	50	1872 to 1st January, 1876	158	5	3-16	Chief of brigade, Emil Lochner
Breslau	240,000	3	...	150,221	8	5	...	65	...	65	1873 to 1st January, 1876	508	29	5-71	Chief of brigade, Mende

Average 4-05

TABLE II.
GENERAL ARRANGEMENT AND STATISTICS OF FIRE TELEGRAPHS.

Town.	Population.	Telegraph Lines.			Speaking Stations.		Bell Alarm Stations.	Automatic Annunciators.	Fires.			Data received from	Remarks.	
		Circuits.	Feet underground.	Feet over-ground.	Morse.	Dial.			Year.	Number.	Serious.			Per cent serious.
Bremen	110,000	4	...	51,873	...	12	19	...	1872 to 1st January, 1876	1580	29	1.90	Chief of brigade, Schumann	The low per-centage of serious fires in Bremen is due, besides to the fire telegraph, to the massive construction of the buildings, to the great perfection and efficiency of the brigade, and to the high intelligence of the Commandant.
Elberfeld	81,000	6	...	38,048	...	*10	6	29	October 1874, to 1st January 1876	18	2	11.11	Chief of brigade, Dietze	* The ten dial instruments are for indicating the locality of the fire and are placed in the houses of officials; they are not used for speaking purposes.
Brunswick	69,000	5	...	65,600	...	18	10	...	1873 to August 1876	369	4	1.09	Chief of brigade, F. W. Reuter	There is also a look-out tower 236 feet high.
Cologne	135,500	4 speaking, 5 annunciators	59,696	4	...	43	1873 to 1st January 1876	265	20	7.58	Chief of brigade, Brüllow	Cologne has a very efficient brigade and abundant water supply; there is a hydrant every 65 yards distant.

FIRE TELEGRAPHS.

Mannheim	28,746	5	...	51,004	*2	27	1873 to 1st January, 1876	52	7	13-46	Chief of brigade, Froben	One battery of 20 Meidinger elements for all five lines working with permanent current. Central station has one relay for each line circuit, with local battery of six elements, one alarm bell, and one self-starting Morse to receive the fire signals. * Central station and house of chief of the brigade have each one Morse for speaking, and are not ordinary speaking stations of the fire telegraph system.
Düsseldorf	80,600	4	33,882	2,821	...	4	2	15	1874 to 1st January, 1876.	107	5	4-67	Chief burgomaster, Becker.	The annunciator signals are received at the central station by a self-starting Morse, worked with permanent current.
Leipzig	126,000	4	54,540	17,197	...	32	1873 to 1st January, 1876	482	30	6-22	Chief of the brigade, Meister.	Massive buildings, and highly efficient brigade; there are three look-out towers in telegraphic connection with central station.
München	193,450	6	...	111,520	4	11	10	6	†	†	†	†	Town surveyor, Zenetti.	In eleven houses belonging to town officials, chiefs of the brigade, are electric house-bells. † The fire telegraph not yet being long enough in operation the per-centage of fires cannot be given, but as far as can be seen the per-centage of serious fires has decreased.

FIRE TELEGRAPHS.

[28th Feb.

TABLE II.—continued.

Town.	Popula- tion.	Telegraph Lines.			Speaking Stations.		Bell Alarm Stations.	Automatic Annunciators.	Fires.			Data received from	Remarks.	
		Circuits.	Feet un- derground.	Feet over- ground.	Morse.	Dial.			Year.	Num- ber.	Serious.			Per cent serious.
Manchester	400,000	*	*	*	...	19	Average per annum.	300	30	10.00	Super- intendent, Alf. Sizer.	The telegraph system is under the control of the police.
Leeds	300,000	*	*	*	...	11	Average per annum.	170	8	4.70	Chief Con- stable, H. Henderson.	Fire brigade and fire telegraphs are managed by the police force. Leeds, compared with other towns in the kingdom, is singularly free from "se- rious" fires.
Liverpool	500,000	*	..	* 84,480	...	17	1865 to 1st January, 1876	2,328	No classifica- tion kept in central of- fice.		Head Con- stable and fire director, Major T. T. Greig, C.B.	The fire brigade is composed of members of the police force. Telegraph lines from central Police office to all police and fire stations; all telegraph instruments under police con- trol, furnished and kept in order by the postal authori- ties.
Popbils	245,722	2 radial	...	6,096	...	4	1875	250	14	5.60	Robert Ingram, chief of fire brigade.	There are in all six dial instru- ments; four of them, together with 2,559 feet overhouse line, belong to the fire brigade; the remaining two instruments, and 3,537 feet overhouse line, belong to the Post Office tele- graph department.

Duisburg	92,000	16 radial	2,302	944,640	...	11	...	6	1873 to 1st January, 1876	342	13	3-80	Chief of brigade, Mr. Bade.	Radial system established in 1869. Massive buildings, highly efficient brigade, and water supply at very high pressure.
Sheffield	250,000	*	*	47,620	...	5	1871 to 1st January, 1876	292	118	40-41	Superintendent of fire brigade, J. Pound.	Instruments and lines belong to the Post Office. Engines are seldom used; the fires are chiefly extinguished by the pressure from the mains.
Augsburg	57,210	11 radial	...	50,742	...	†	2	21	1870 to 1st January, 1876	53	15	28-30	Chief of brigade, Leybold.	Central station is at the chief police office. † The dial apparatus are not the usual magneto-electric dial apparatus, but worked by clockwork released by battery currents. Central station has a battery of twelve zinc carbon elements, the other stations have batteries of five elements.
Elbing	34,000	1 circuit 1 radial	...	36,080	...	14	6	...	1875 to 12th Sept. 1876	21	3	14-29	Chief of brigade, Klein.	
Glasgow	600,000	†	†	211,200	...	12	10	§	1875	352	14	4-00	James Brysen, chief of fire brigade.	The whole of the police and fire brigade stations are connected, all terminating in the central fire station and central police station. § In a large number of warehouses and factories fire detectors are fitted up, which ring a bell placed outside of the building when the temperature is increased by fire occurring inside.

† Property of the Post Office authorities.

* Rented by the police from the Post Office authorities.

TABLE II.—continued.

Town.	Population.	Telegraph Line.			Speaking Stations.		Bell Alarm Stations.	Automatic Annunciators.	Fires.			Data received from	Remarks.	
		Circuits.	Feet underground.	Feet overground.	Morse.	Dial.			Year.	Number.	Serious.			Per cent serious.
Brussels*	188,609	Radial	...	16,400	22	1873 to 1st January, 1876	327	51	15.59	Chief of police Lenant, and Edward Ran civil engineer.	There is no proper fire telegraph in Brussels. Municipality messages, fire messages, &c., can be sent by the ordinary town telegraph, which is not connected with fire brigade stations.
Edinburgh	200,000	†	†	†	...	7	15th May, 1871, to 15th May, 1876	635	100	15.75	Fire master Samuel B. Wilkins.	Six district stations are in direct communication with the central or chief police office, and all adjoining police stations. The telegraphic instruments are under the control of the police and used for any other business connected with the police.
Königsberg	120,000	6	...	196,800	...	5	48	5	1873 to 1st January, 1876	180	43	23.88	Chief of brigade, von Berhardt.	The brigade has a military organisation since 1873. There are three speaking circuits and three signal circuits with one Morse at central station; the five bell alarms are placed in barracks.

Hanover	108,000	Radial	...	88,700	1873 to 1st January, 1876	162	12	7-41	General inspector of brigade, Berg.	All lines, except one, join at the central station. The one bell alarm is at the house of the chief. Each dial station has an induction bell.
Newcastle-upon-Tyne	180,000	Radial	...	20,997	6	1871 to 1st January, 1876	287	77	26-88	Edward Selby, secretary and chief clerk of brigade	One of the six stations is at the private residence of the director of brigade. All stations have, besides the dial apparatus, a bell for alarm.
Birmingham	396,076	Radial	...	7,040	5	1875	71	16	22-63	G. Tivioletall, superintendent of fire brigade	Fire brigade is in connection with the police force, and under control of the town council. The central fire station is close to the central police station.
Mull	130,000	Radial	†	†	2	1871 to 1st January, 1876	85	Majority over 50-00		Chief constable, Th. Cook	There is only one line from chief constable's office to the waterworks in order to increase the pressure in case of fire. The police force act as fire brigade.
Bradford	145,830	Radial	...	About 52,800	5	1870 to 1st January, 1876	250	150	60-00	Superintendent of fire brigade, Joseph Hudson	The telegraph stations are not at the fire brigade stations but at the district police stations, and are connected with the central police station.
Nottingham	125,000	3 Radial	...	Lines over- ground	22	1873 to 1st January, 1876	140	3	2-14	Chief constable Nollin	The three lines join at central police station, where the battery for the alarm bell stands.

* No fire telegraph, only town telegraph.

† All lines overground, and property of Post Office authorities.

TABLE II.—continued.

Town.	Population.	Telegraph Lines.			Speaking Stations.		Bell Alarm Stations.	Automator.	Fires.			Data received from	Remarks.	
		Circuits.	Feet underground.	Feet over-ground.	Morse.	Dial.			Year.	Number.	Serious.			Per cent serious.
London	2,805,000	Radial	155,640	578,010	...	53	1871 to 1st January, 1876	8,026	850	10.5	Partly from Captain Shaw, chief of brigade and partly from Post Office telegraph department	The 53 dial stations have 100 instruments; 84 of these are Siemens' and 16 Wheatstone's. There is in London, besides the Metropolitan fire brigade telegraph, but not connected one with the other, the Metropolitan police telegraph with 93 dial instruments and 269 miles 510 yards of telegraph line, 12 miles and 1,160 yards of which are underground.
Sunderland	120,000	3 Radial	...	9,810	...	4	1872 to 1st January, 1876	123	46	37.4	J. Staensly, chief constable, chief of brigade	From the central police station, which is the chief fire station, run three lines to three fire stations.
Salford	124,801	6 Radial	...	60,720	...	8	Yearly average	65	5	7.7	Robert Hall, superintendent of fire brigade	The head police station is connected with two divisional and three sub-police stations; there is also a private wire in connection with two large mills.
Nürnberg	92,000	Radial	...	18,368	2	7	2	...	1872 to 1st January, 1876	50	16	32.0	Chief of brigade, Franz Wolfermann	Nürnberg is just improving her fire telegraph system, establishing 25,584 feet over-ground line, four Morse stations, five dial stations, two bell-alarm stations, and a large number of automatic fire annunciators.

Liegnitz	30,400	Radial	...	16,400	...	1	3	7	The fire telegraph was only established in the year 1876, and statistical data therefore could not be given	Chief of brigade, Sagelsdorf	The central station has a bell and galvanoscope which indicate the alarm signals from the annunciators; the battery consists of 15 Leclanché elements.
Oldham	113,100	Radial	...	5,280	...	3	1874 to 14th November, 1876	Chief of brigade and chief constable, Charles Hodgkinson.	
Paris	1,952,295	Radial	All lines underground.	85	1875	Prefecture de Police	There is one central station radially connected with 12 principal stations, and each of those is again radially connected with 5 to 7 less important fire brigade stations, making altogether 85 stations.
									Average . . .	17.6	

TABLE III.

TOWNS WITHOUT FIRE TELEGRAPHS.

Town.	Country.	Popula- tion.	Year.	Total fires.	Serious fires.	Per cent. serious.	Data received from
Mannheim	Germany	46,500	1870 to 1st Jan. 1876	45	21	46·6	W. Wirsching, chief of brigade.
Wiesbaden	Germany	48,000	1872 to Sept. 1876	36	7	19·4	C. R. Scheurer, chief of brigade.
Belfast	Ireland	180,000	1873 to 1st Jan. 1876	195	66	33·8	George A. Reilly, superintendent of fire brigade.
Frankfort-on- the Oder	Germany	47,346	1873 to 1st Jan. 1876	65	10	15·4	Christ, chief of brigade.
Gand	Belgium	131,016	1873 to 1st Jan. 1876	60	29	48·3	Burgomaster and magistrate of Gand.
München	Germany	193,000	1875	34	9	26·5	From official yearly report.
Erfurt	Germany	47,500	1866 to 1st Jan. 1876	116	18	15·5	Chief burgomaster Kirchoff.
Dortmund	Germany	58,000	1870 to 1st Jan. 1876	136	28	20·6	Chief of brigade Sonnenschein.
Liège	Belgium	121,208	1873 to 1st Jan. 1876	23	19	82·6	Burgomaster of town.
Dundee	Scotland	120,000	Sept. 1875 to Sept. 1876	68	7	10·3	Supt. fire brigade, R. D. Ramsay.
Aberdeen	Scotland	20,200	1873 to 1st Jan. 1876	105	15	14·3	William Boulton, master of engines.
Paialey	Scotland	48,321	Per year	30	5	16·7	James Gillespie, chief of brigade.
Leith	Scotland	50,000	1870 to 1st Jan. 1876	114	12	10·5	James Brown, chief of brigade.
Greenock	Scotland	59,111	1870 to 18th Oct. 1876	209	36	17·2	G. Macartney, superintendent of fire brigade.
Portsmouth	England	120,000	1st Sept. 1873 to 1st Sept. 1876	84	14	16·7	Chief of police.
Wolver- hampton	England	60,860	30th Sept. 1874, to 30th Sept. 1876	41	21	51·2	Captain Segrave, chief constable.

TABLE III.—*continued.*

Town.	Country.	Popula- tion.	Year.	Total fires.	Serious fires.	Per cent. serious.	Data received from
Posen	Germany	60,000	1845 to 21st Oct. 1876	234	120	51·3	Herrmann Lischke, chief of brigade.
Bromberg	Germany	31,000	1875 to 17th Oct. 1876	58	19	32·8	Boie, chief magis- trate.
Leicester	England	95,220	1875	32	12	37·5	J. W. Johnson, superintendent of fire brigade.
Würzburg	Germany	45,000	1871 to 10th Oct. 1876	80	30	37·5	M. Scheuring, chief of brigade.
Utrecht	Holland	53,083	1849 to 1st Jan. 1876	187	56	29·9	From fire brigade department of town.
Rotterdam	Holland	260,000	1851 to 1st Jan. 1876	1520	157	10·4	From fire brigade department of town.
Maastricht	Holland	23,279	1860 to 1st Jan. 1876	113	27	23·9	From fire brigade department of town.
Arnhem	Holland	36,500	1861 to 1st Jan. 1876	42	13	30·9	From fire brigade department of town.
Leiden	Holland	37,000	1865 to 1st Jan. 1876	50	8	16·0	From fire brigade department of town.
				Average		28·6	

that a "serious" fire is such as requires more than two engines or fire-reels for its extinction.

The first table includes the towns having what may be considered the most perfect systems of Fire Telegraphs, viz., the system of Morse speaking stations, automatic fire annunciators, and chiefly underground lines. The second table includes the towns with dial stations, chiefly overhead lines, and with only few or no fire annunciators.

From these tables we see that towns with perfect Fire Telegraph systems have their serious fires reduced to an average per-centage of 4; the less perfect systems show more frequently serious fires, reaching an average number of 17; while the per-centage in towns possessing no fire telegraphs reaches as high as 29.

It could easily be shown that the per-centage of fires resulting in "total destruction" must likewise be exceedingly high in towns without Fire Telegraphs, but it suffices to give a single case, which well represents the average of their class, viz.: the town of Antwerp, in Belgium, with 160,513 inhabitants. The total number of fires during the two years of 1873 and 1874 was 37, with 5 "total destructions;" thus giving the alarmingly high result of 13.5 per cent. of fires ending in total destruction.

The city of Paris, on the other hand, furnishes ample proof of the reduction of fires resulting in total destruction after the introduction of Fire Telegraphs. I regret that I have not been able to obtain a classification of the Paris fires according to the basis adopted in this paper, viz. proportion between "total number" and "serious fires;" but I have obtained from the chief office of police, statistics which are classified according to the value of damage done. This list, which unfortunately, by reason of this varied classification, cannot be grouped in my Table No. II., and from which no conclusion can be drawn regarding the diminishing influence of the Fire Telegraph on the per-centage of "serious" fires, shows that the average "total destruction" fires have diminished 50 per cent. since the year 1870, the time in which the Fire Telegraph was introduced.

FIRES IN PARIS.

Year.	Total number of Fires.	Damage done.			Average destructive Fires per annum.	Per-centage of Fires resulting in total destruction.
		Under 100 francs.	From 100 to 100,000 francs.	Over 100,000 francs.		
1860	2,342	1,742	596	4	3·9	0·15
1861	2,347	1,573	772	2		
1862	2,148	1,451	685	2		
1863	2,784	1,962	820	2		
1864	3,381	2,334	1,044	3		
1865	3,141	2,213	926	2		
1866	2,488	1,702	781	5		
1867	2,781	1,878	917	6		
1868	2,946	1,950	987	9		
1869	2,602	1,679	919	4		
1870	2,223	1,319	902	2	1·8	0·09
1871	1,140	552	587	1		
1872	1,832	1,189	642	1		
1873	1,862	1,188	670	4		
1874	2,228	1,499	726	3		
1875	2,412	1,614	798	0		

The following table gives the proportion between the population and the number of points from which an alarm may be telegraphed (see next page).

COMPARATIVE TABLE showing the proportion between population and number of Points from which Electrical Fire Alarums can be given.

Town.	Country.	Population.	Proportion.
Chicago	U. S. America	350,000	1 point to 780 inhabitants*
Memel	Germany	28,000	1 " 990 "
Boston	U. S. America	250,526	1 " 1,000 "
Cincinnati	U. S. America	216,239	1 " 1,000 " *
St. Louis	U. S. America	400,000	1 " 1,000 " *
Aix-la-Chapelle	Germany	80,000	1 " 1,013 "
Magdeburg	Germany	85,000	1 " 1,349 "
Frankfort-on-the-Main	Germany	103,136	1 " 1,375 "
Elbing	Germany	34,000	1 " 1,700 "
Amsterdam	Holland	290,000	1 " 1,824 "
San Francisco	U. S. America	200,000	1 " 2,000 " *
Elberfeld	Germany	81,000	1 " 2,077 "
New York	U. S. America	957,000	1 " 2,093 " *
Augsburg	Germany	57,210	1 " 2,200 "
Königsberg	Germany	120,000	1 " 2,264 "
Brunswick	Germany	69,000	1 " 2,464 "
Liegnitz	Germany	30,400	1 " 2,764 "
Cologne	Germany	135,500	1 " 2,883 "
Breslau	Germany	240,000	1 " 3,077 "
Stettin	Germany	81,072	1 " 3,118 "
Hamburg	Germany	339,400	1 " 3,327 "
Leipzig	Germany	126,000	1 " 3,337 "
Dusseldorf	Germany	80,600	1 " 4,030 "
Berlin	Germany	980,000	1 " 4,516 "
Danzig	Germany	92,000	1 " 5,412 "
München	Germany	193,450	1 " 6,240 "
Brussels	Belgium	188,609	1 " 8,573 "
Bremen	Germany	110,000	1 " 9,166 "
Nürnberg	Germany	92,000	1 " 9,200 "
Hanover	Germany	108,000	1 " 9,818 "
Salford	England	124,801	1 " 15,600 "
Manchester	England	400,000	1 " 21,053 "
Paris	France	1,952,295	1 " 22,968 "
Leeds	England	300,000	1 " 27,273 "
Glasgow	Scotland	600,000	1 " 27,500 "
Edinburgh	Scotland	200,000	1 " 28,571 "
Bradford	England	145,830	1 " 29,166 "
Liverpool	England	500,000	1 " 29,412 "
Newcastle	England	180,000	1 " 30,000 "
Sunderland	England	121,000	1 " 30,250 "
Oldham	England	113,100	1 " 37,700 "
Sheffield	England	250,000	1 " 50,000 "
London	England	2,805,000	1 " 52,925 "
Dublin	Ireland	245,722	1 " 61,431 "
Hull	England	130,000	1 " 65,000 "
Birmingham	England	396,076	1 " 79,215 "

* The proportions of American towns are taken from the above quoted "Times" article of the 17th August, 1876; all others have been compiled from direct correspondence with the Chiefs of the Fire Brigades.

One of the strongest arguments in favour of a Fire Telegraph system is the saving on insurance, which must naturally follow from a reduction in the per-centage of serious fires. That such reduction has actually taken place has been shown generally by the previous table, but I will show it more detailed for a few particular towns (see table, next page).

It would be departing from my subject too much if I were to lay before you an estimate of the millions that have been saved, or the millions that may be saved, by the adoption of Fire Telegraphs. Such calculations I leave to the Insurance Companies, and will only endeavour to show by a few data the financial and economical value of the system. In the town of Brunswick, in Germany, in one year, when there were no serious fires, only £282 was paid by the Insurance Companies. In two other years, when there were four serious fires, £17,000 extra was paid—

Year.	Fires.	Serious.	Insurance Value.	Insurance Paid.
1873	95	2	£9,093,870	£1,939
1874	96	0	£9,746,648	£282
1875	104	2	£10,498,338	£15,364

I may add to this table the most recent communication which I have received on this subject. The Superintendent of the Salford (England) Fire Brigade, Mr. Robert Hall, wrote me on the 17th October last year: "The complete system of telegraphs in this borough has enabled us to save many thousands of pounds in cases of fires."

In America the same result is obtained. The Superintendent of the St. Louis Fire Telegraphs, H. C. Sexton, in his report of 1860, says: "A comparison of the two years' working of the department prior to the establishment of the electric alarm, with the two subsequent ones, shows the following results: "From 1856 to 1858 the amount of losses was 1,803,315 dols., against 710,404 dols. from 1858 to 1860, showing a diminution of 1,097,911 dols. or 548,955 dols. annually, and, on the principle that prevention is better than cure, we claim for the Fire Alarm Telegraph a large share of the credit in saving that amount."

The Chief of the Montreal Fire Department, A. Bertram, in his

TABLE SHOWING THE DECREASE OF SERIOUS FIRES AFTER ESTABLISHING THE FIRE TELEGRAPH.

Fires before the Telegraph was Established.				Fires after the Telegraph was Established.			
Town.	Total.	Serious.	Per-centage.	Town.	Total.	Serious.	Per-centage.
Amsterdam	{ 1858 1874 }	403	9.71	Amsterdam	{ 1875 July 1876 }	26	2.79
Elberfeld	{ 1873 October 1874 }	5	26.32	Elberfeld	{ October 1874 August 1876 }	2	11.11
Magdeburg	1873	10	19.61	Magdeburg	{ 1874 September 1876 }	13	6.99
Hamburg	{ 1860 1872 }	238	6.31	Hamburg	{ 1873 1st January 1876 }	36	1.77
Aix-la-Chapelle	{ 1870 1871 }	60	18.33	Aix-la-Chapelle	{ 1872 1st January 1876 }	5	3.16
Nürnberg	{ 1865 1871 }	50	45.87	Nürnberg	{ 1872 1st January 1876 }	16	32.00
Breslau	{ 1859 1865 }	84	8.40	Breslau	{ 1866 1st January 1876 }	84	6.40
Frankfort-on-the-Main	{ 1866 May, 1875 }	76	20.43	Frankfort-on-the-Main	{ 9th May 1875 31st October 1876 }	7	5.00
	Average		19.37		Average		8.65

report of 1866, says: As the simplest illustration of the great value of the Fire Alarm Telegraph, we have the fires and loss for a fair average before and since its introduction—

Before, 85 fires	140,088	dols. loss.
Since, 99 ,,	35,428	,, ,,

Mr. Joseph L. Perley, Chief Engineer of the Fire Department of New York City, and now President of the Board of Fire Commissioners, says: "It would be difficult to estimate the value of the Fire Alarm Telegraph. I have known cases where lives have been saved by the quick method of communicating the intelligence of fire--the value in money would amount to millions."

The Honourable J. C. Cuyler, one of the Fire Commissioners of Albany, testifies: "I give it as my opinion, from my knowledge of the localities in which fires have occurred, the character of the buildings, and the nature of their contents, that it would be a moderate estimate to say that it (the Fire Alarm Telegraph) has effected in Albany a saving of at least one quarter of a million dollars annually;" and the Chairman of the Board of Fire Commissioners of Hartford says: "To the best of my judgment, our losses since the introduction of the Fire Alarm Telegraph have not been one-tenth of what they were before."

That the necessity for extended Fire Telegraph systems is equally felt in Great Britain may fairly be judged from a report of 1875 from the Chief of the Dublin Corporation Fire Brigade Department, Mr. Robert Ingram, who says: "I furthermore would recommend that the different police stations throughout the city be connected by magnetic telegraphs with the chief fire station, with coloured signals attached to alarm bells. By this means we should be enabled to get quicker intelligence of the locality of fire, as at present the police are obliged to take the first means of conveyance, such as a car or cab. It is my impression, from my knowledge of the city, that a vast amount of property might be saved by this means of communication with the brigade."

But it is needless for me, I feel sure, to add any further argument upon a point which must be self-evident to everyone. I ought

rather to apologize for bringing forward so many facts and laying before you so many expressions of opinion on this point.

A secondary, though no less interesting, advantage to be gained by Fire Telegraphs has been pointed out to me by Mr. Frobeen, Chief of the Memel Brigade, who says: "After forty years' experience as chief of the brigade I can assure you that since the establishment of the Fire Telegraphs there are not only very few serious fires but there are no cases of *incendiarism*, so little chance of success being left to the incendiary in a place where most of the fires are quenched in their infancy."

The following table of Stettin fires, from 1865 to 1875, I have arranged according to the means employed to extinguish them, and as by far the greater number were extinguished in their infancy they furnish good testimony of the efficiency of the Fire Telegraphs, and go far to corroborate Mr. Frobeen's opinion (see table, next page).

The truth of it must however appear evident to all, upon the meanest consideration, for it stands to reason that the incendiary will be far less likely to carry out any of his nefarious schemes when the certainty exists that in the course of a few minutes a policeman, or other officer connected with the fire brigade, will be on the spot, and so able to detect him. I need not, therefore, waste more of your time in discussing the point.

I am well aware, Gentlemen, that the statistics I have laid before you are far from complete, but any addition to them cannot materially alter the conclusions to which they all point. These conclusions briefly summed up are :

1. That the towns without Fire Telegraphs are liable to a very high per-centage of serious fires, the cause of this being unquestionably the time lost in calling out the fire brigade.
2. That the employment of Fire Telegraphs in all cases leads to a decrease in the per-centage of serious fires, and that the more perfect the Fire Telegraph is the greater the reduction effected in the per-centage of serious fires.

The principles of construction claimed by a perfect Fire Telegraph system are shortly these :

FIRES IN STETTIN.

YEAR.	Series fires requiring more than two fire-engines.	Middle fires requiring from one to two fire-engines.	Small fires requiring only a hand hose.	Small fires extinguished without special fire apparatus.	Chimney fires.	Total fires.	Percentage of serious fires.
A	B	C	D	E	F	G	H
1865	1	21	2	21	11	56	1.79
1866	1	10	2	20	13	46	2.17
1867	2	10	6	20	17	55	3.63
1868	4	11	5	18	21	59	6.78
1869	5	7	7	23	18	60	8.33
1870	1	3	11	21	16	52	1.92
1871	3	10	4	19	36	72	4.17
1872	2	15	9	27	21	74	2.70
1873	1	6	6	26	24	63	1.59
1874	4	6	9	34	15	68	5.88
1875	4	7	7	20	20	58	6.89
	28	106	68	249	212	663	4.17

- (a.) Entire control and management of the line by the Fire Brigade department.
- (b.) Underground cables.
- (c.) A system of circles or radii, with a suitable number of speaking stations and automatic fire annunciators, all terminating in one or more central stations, from which commands are issued to the entire system.
- (d.) That the stations and annunciators be so chosen that each part of the town be as near as possible to a point of alarm; that the closed circuit system be preferably adopted, and the Morse in preference to other speaking instruments.

These points might be modified as local circumstances require.

In conclusion I would acknowledge the kind assistance rendered to me by the chiefs of the brigades of many English, German, and other continental towns, in having furnished me willingly with the statistical data which I have laid before you. I must also express my thanks to our Vice-President, Mr. C. Siemens, for having afforded me the opportunity of exhibiting the apparatus before you; and to you, Gentlemen, for having listened to my remarks with so much patience.

The CHAIRMAN: We shall be glad to hear any remarks upon the important paper which has been brought before us.

Mr. MONTEFIORE explained the Autokinetic system by means of several instruments exhibited by him.*

He said:—I have here an autokinetic instrument such as may be attached to a lamp-post in the street, also two others as they would appear fitted in iron street-posts, and one suitable for private houses. The merit claimed for this system is that it enables uninterrupted messages to be sent. Any number of stations may be set to deliver their several messages by merely turning this handle round, and it waits till the instrument first operated has completed its message. You see the great advantage of this is that no message can be interrupted by another. We have just heard that

* A more complete description of this system will be found at page 143.

it seldom occurs that one message is at all likely to be interrupted by another, but I dare say, amongst so many connected with telegraphy, most of you know that messages do very often interrupt each other. I have been engaged twenty years in telegraphy, and my experience is that there are numerous complaints of interruptions. The argument put forward is, that if it is merely for fires it would not have that effect, because there are so few fires comparatively; and it has been stated that in Frankfort, Hamburg, and Amsterdam no interruption of messages has occurred; but this was afterwards qualified, and it was said that there had been one or two partial interruptions. What do we find? We find that in Frankfort there are ten stations and sixteen enunciators in circuit. This would not give an average of two transmitters to each receiver, therefore the chance of interruption is very small. But, if this system were adopted on the extensive scale which would be necessary for London, imagine what it would be! Frankfort is divided into such small circles that I dare say if three instruments were placed in circuit it would seldom occur that more than one of the instruments would be started at one time. But if we had a large number of these instruments at every 200 yards, which is about the distance that is thought desirable, there must be a great number of instruments in circuit, and if you bring the system to the greatest perfection, and have it in private houses, then there is not only great probability, but great certainty, that almost every hour messages would be interrupted, more particularly if the instruments were used not only for fire stations but also for police purposes. Those on the continent are used only for fire. Another advantage is that by this instrument we can send to different stations at will and not merely to the head station from whence the messages have to be repeated to other systems, thus causing delay.

Briefly we claim the following advantages for the autokinetic system.—Firstly, an automatic method of signalling to various stations at will; secondly, the impossibility of interruption from any other signalling apparatus in circuit while any message is being transmitted; thirdly, the employment of an open circuit, saving battery power, and, what is still more important, the deterioration

of underground wires, which is so serious when a constant current is used ; fourthly, simple mechanical arrangements for altering the character of the signal, so that any message can be sent automatically ; also, a means provided to enable an experienced operator to communicate with the receiving station as with an ordinary Morse key ; and finally, that the autokinetic instrument is so simple and compact that it could be easily attached to ordinary lamp-posts, placed in other street posts, or hung in the halls of private houses ; and all that is required to insure the message being sent is to turn a small handle once round, relying on the certainty that no interruption can take place while the message is in transmission.

The working of the instruments was then explained.

Mr. HIGGINS : You will, perhaps, be surprised to learn that we have at work in the City of London as many as 600 of these annunciators. The difficulties which have been pointed out do not exist in practice—we have never experienced any interruption of one signal by another. In the working of such a system it is not absolutely necessary to have apparatus which is non-interruptable, and we find that this system works perfectly well. Out of many thousands of messages I have never heard of any running one into the other. We have had failures from wires being broken, but we have never had a complaint of two signals running into each other. There is provided to each instrument a small galvanometer which intimates to the sender when the line is occupied, and he does not then make use of it. The instruments before me are adapted for private houses, the one in a water-proof case is for municipal purposes. This system is similar to that mentioned by Mr. Treuenfeld as in use in 79 cities of the United States.

[Here Mr. Higgins exhibited the working of the several instruments placed there for the purpose.]

The signal is recorded on paper in dots and spaces, and the bell continues to ring till the acknowledgment is sent. Any number of signals may be sent on a circuit. To prevent one signal running into another it is only necessary that the Morse receiving apparatus should be provided with an automatic current-reversing arrangement. If you cause each signalling instrument, when set, to be liberated by a current in a certain direction, a current in

another direction may be made to prevent liberation of the clock-work, and by that means interruption of messages may be effectively prevented.

About 600 signalling instruments may be put upon a single circuit, but in the city we have only about 200, which are enough eggs to put into one basket, for if they all broke down together it would be rather inconvenient. I think, perhaps, 50 instruments in one circuit are quite sufficient.

Mr. MONTEFIORE: It is implied, though not actually expressed, that the autokinetic system is inferior, because no inconvenience has been experienced from signals becoming confused when only a few instruments are joined up; it is impossible that this can happen with the autokinetic system. I contend that the autokinetic system is not only good as far as this system goes, but so far better that it is impossible with any number of instruments joined up that there can be any confusion of messages. In the case of the system I have explained, you do not have to wait until the line is clear; there is no fighting for circuit; but you have simply to turn a handle similar to a bell-pull and the messages go automatically in rotation. Another advantage is, supposing a fire breaks out in a house, you can put your message on, and you have not to wait to see whether the receiving station is ready. You can rely upon the mechanism that it will go in its turn, and in the meantime you can, in case of fire or burglary, collect your chief valuables together, resting absolutely certain that the ear of the intended receiver will be reached without further effort on your part.

Mr. HIGGINS: I endeavoured to explain, that by a one-wire system it is quite possible to do all that is claimed by the autokinetic system, and that, I think, disposes of its superiority over anything else. The original of the system of the Exchange Telegraph was tried in the United States about twenty-six years ago, and has been working in a great many towns ever since.

The CHAIRMAN: We are glad to hear of the advantages of any system that is introduced, but I would rather gentlemen confine themselves to the advantages of their systems, and not go into the disadvantages of others.

Mr. HIGGINS begged to be allowed to remark that he pointed out no disadvantages. Mr. Montefiore had stated that a certain

system was liable to interruption; he (Mr. Higgins) wished to point out that it was possible to effectually prevent interruption.

Mr. VON TREUENFELD (in response to the call of the Chairman): There is not much for me to reply to, chiefly because the remarks that have been made do not apply to the main subject of my paper, which has relation to Fire Telegraphs, and their influence on the prevention of destruction of property by fire. I have always been under the impression that for a perfect fire telegraph it is not only required to be able to send the fire alarm signals, but also messages of any kind, whether upon police affairs or for calling the aid of the fire brigade, it being understood that in the case of fire-messages being sent the municipal messages cease, and are continued only on the conclusion of the fire. I think there can be no doubt that in a perfect fire telegraph the Fire Brigade ought to have the management in their own hands, and ought not to occupy themselves with household messages, as explained in the two systems exhibited by the Autokinetic and Exchange Companies. They are very interesting for the special purpose of private telegrams for cities, but they do not strictly answer as fire telegraphs, because there are certain conditions required in a fire telegraph which these systems do not permit of. Suppose a fire breaks out, the intelligence, as before explained, will be sent to the central station, whence instructions are issued to the other stations, as reports of the state of the fire come in. For a fire telegraph it is necessary that the boxes should possess the means of instantaneously communicating any message between the box nearest the fire and the central station, and as far as I can see the autokinetic system does not allow of this. The details given in the paper show very distinctly that the system I have explained is adapted for instant communication between the boxes and the central fire station. Mr. Montefiore says the messages are liable to destroy each other, and that that has been the case. It is not so stated in the paper, and I have the reports of the chiefs of the same fire telegraphs which I fully described in the paper, and which state that no instance has occurred of messages having destroyed each other.

Mr. MOIR: You showed that if one message was being sent and another was put on the first message would be confused at the *latter end*.

Mr. TREUENFELD : If two fire alarms were sent at nearly the same time, the beginning of the second series would be destroyed and the end of the first, but both signals would be readable.

Mr. MOIR : You admit that the two would be confused—part of one and part of the other?

Mr. TREUENFELD : An entire fire alarm consists of twelve signals of the same kind. The central station requires to receive only one of those twelve signals, the other eleven are repetitions for the sake of security. It is said that this system admits of only a limited number of messages. That is not the case, inasmuch as municipal messages in unlimited numbers, as well as fire-service messages, are sent, and the application of the system is in no degree confined to any particular size of town. The system at Amsterdam could be applied to a place six times as large, by simply establishing a greater number of circles. A question has been raised as to the relative advantages and disadvantages of those several systems. There can be no doubt that a system requiring only one line-wire has an advantage over one which requires two wires, and I understand that the autokinetic system requires two wires, and the apparatus appears to me too complicated and delicate to be used by unskilled operators. An instrument for use in the hands of the police ought to be as strong and as simple as possible and not put in too small a compass. The question that messages do not efface each other has been so definitively settled that it is not necessary for me further to discuss it. The apparatus exhibited to-night by the Autokinetic and Exchange Companies are no doubt admirable for the particular purpose of city telegraphs, but as the subject of my paper is fire telegraphs I have nothing more to say about them.

The CHAIRMAN : We may congratulate ourselves that we have this evening heard a paper of not only great technical interest but one introducing a means of great public and social economy in a more prominent way than could have been done by any private undertaking. As it is understood that some further information will be forthcoming, the further discussion of the subject will stand over for the next meeting.

The meeting was then adjourned.

The Fifty-fifth Ordinary General Meeting was held on Wednesday, the 14th day of March, 1877, Professor ABEL, President, in the chair.

The PRESIDENT: It was announced at the conclusion of the last meeting that the discussion upon the valuable paper of Mr. Treuenfeld would be resumed this evening. That is intended, if time permits, but Mr. Higgins, who has written a paper upon a type-printing telegraph apparatus, a subject of very general interest, has brought here a number of instruments to illustrate it, some of which it will be impossible for him to bring on a future evening. I think it will be the general feeling of the members that we shall give precedence to Mr. Higgins's paper on the type-printing telegraph, and, if time permits, without entering upon the discussion of Mr. Higgins's paper, we will resume the discussion on the paper of Mr. Treuenfeld. If that is the desire of the meeting, I will now call upon Mr. Higgins to read his paper on type-printing.

A DESCRIPTION OF THE AUTOMATIC STEP-BY-STEP TYPE-PRINTING TELEGRAPHIC APPARATUS USED BY THE EXCHANGE TELEGRAPH COMPANY.

By FREDERICK HIGGINS, (Exchange Telegraph Company).

The class of apparatus which I am about to introduce to your notice, although very well known and extensively used in the United States of America, is not, I believe, very familiar to electricians or the public in this country.

Its employment here, however, is only a question of time and opportunity. I have no doubt that in future important intelligence, which is at present distributed from great telegraphic centres by hand, will be more satisfactorily disseminated by its means.

A single operator could follow the debates in Parliament at the

the

ind
sed
ber

for
ers
ny
ru-
hes

tus
his
L.
es,
in-
ite.

ck

to
ful
ny
he

un
ter
ial

he
es,
he

or

IN



rate of from fifteen to twenty words per minute, and deliver a summary, printed in Roman characters, simultaneously to all the clubs and newspapers in London.

I gather from various sources that the first apparatus of this kind applied to the distributing business was a three-wire system devised by Mr. E. A. Calahan, of New York, formerly Assistant Engineer to the American Telegraph Company, in the year 1867.*

A Company with a capital of 200,000 dols. was formed for working the system, and instruments were furnished to subscribers in December of the same year. The progress of the Company may be judged of from the fact that some thousands of type-instruments of this and other classes are now applied to various branches of the business in the United States.

A rival company started in the following year to work apparatus containing some modifications of, and improvements upon, this system, which were due, I believe, to Mr. T. A. Edison and Mr. F. L. Pope of New York, and, amongst other ingenious contrivances, contained a zero or unison, insuring arrangements similar in principle to that used in some French type-instruments of earlier date. (This addition will be described later).

This Company was eventually absorbed by the Gold and Stock Company.

Since that time a number of instruments have been invented to perform the same work as the two mentioned, and the successful ones have either been bought up by the Gold and Stock Company or worked in competition with it; after a time the interests of the contending parties have usually been combined.

The best of the latter class of instruments with which I am acquainted are the Phelps and Manhattan patterns, which are faster in operation but more delicate and costly than the substantial apparatus of Calahan and Edison.

Up to the present its only application in this country is to the distribution of the constantly varying prices of stocks and shares, and other financial intelligence collected from various parts of the world.

* An apparatus for showing telegraphically the price of gold was in existence or operation at the time, but with no means of recording the signals.

Description of Original Instrument and Method of Working.

The instrument as originally introduced here from America was the Edison form, requiring, as does our present modification, two lines of wire; on one of these is placed the type revolving, and on the other the printing mechanism. The former consists of two type-wheels fixed to a tube, which slides laterally on the propellent axis.

Each wheel contains 28 characters and two spaces. The propellent consists of a pair of pallets, A, which act on a wheel, with 30 shaped teeth, B, as in fig. 1.

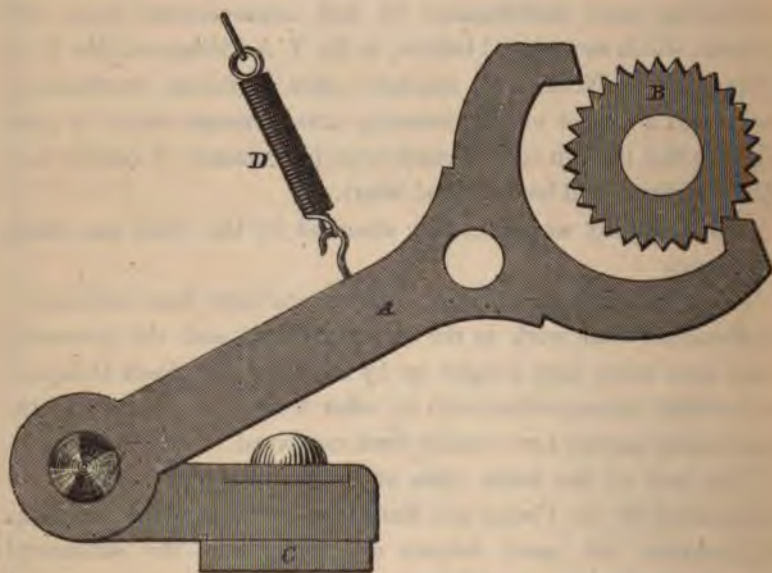

Fig. 1.

The pallets carry an armature of soft iron C, which is suspended over an electro-magnet by an adjustable spiral spring D. They are

formed to move the star wheel forward half a tooth for both the downward movement caused by the attraction of the armature by the electro-magnet, and its recession, caused by the spiral spring on the cessation of the current. It is, therefore, necessary to close and open the battery circuit to rotate the type-wheels through the space occupied by one letter and its necessary margin.

Either type-wheel can be printed from at will by causing them to be arrested with one or other of the blank spaces opposite to the impression pad, and then operating the printing lever; this will upset an anchor-shaped lever *A*, pivoted on a projection from the escapement axis *B*, and attached at its extremity, by a connecting link *C*, to the tube *D*, on which the type-wheels *EE'* are fixed. (Fig. 2.)

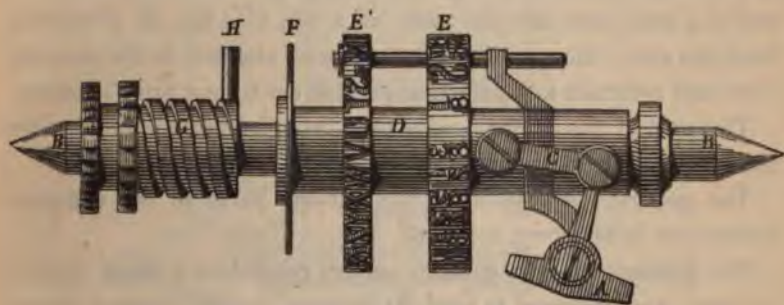

Fig. 2.

The type-wheels can only move laterally when in either of the two above-mentioned positions; a disc *F*, with a slot corresponding in position and size to the two blank spaces, prevents any disturbance of the types with respect to the paper ribbon during their revolution. The extent of the lateral movement is a little more than the width of the largest type.

The paper is partly covered by a shield of thin brass, and the part exposed, being less than the two type-wheels in width, prevents more than one being printed from at a time.

Below the type-wheels is placed the printing mechanism, which consists of a rocking lever, pivoted very close to the electro-magnet by which it is actuated, in order that sufficient momentum for a good print might be acquired, and also to give space for the contrivances by which the type-wheels are changed and the paper fed.

The paper-feeding mechanism is very simple and effective, and is still used in all our instruments; a pawl with sharp teeth held down on to the paper by a spring is moved forward the required distance (.15 in. usually) by a pin projecting from the side of the printing lever; the teeth of the pawl plough into the paper and carry it forward, but in returning slide over it. A similar pawl placed below the other edge of the paper-band and pressing it upward against a fixed brass plate prevents its return.

To set the instruments to zero before starting or in the middle of a message, a worm, G, fig. 2, on the propellant axis carries the end of a steel arm into the path of a pin (H, fig. 2) projecting from the axis; the arm is lifted by a hook attached to the printing lever and returned to its starting point every time a print is made.

This part of the mechanism is only brought into operation when the type-wheels are revolved twice or more without printing.

The general disposition of the various parts in the complete instrument is as shown in fig. 3.

The transmitter is a contact maker, rotated by a crank worked by hand, and arranged to send 30 currents in one direction during a complete revolution of its pointer.

The letters, figures, and spaces, corresponding in order and number to those on the type-wheels, are arranged on the dial.

One battery serves both lines; one pole is put to earth and the other to a key in connection with the printer line, and also to the contact maker in connection with the type line.

The manner of operating is, like the instrument, extremely simple; the transmitter crank is turned several times to bring the escapement axis to the zero stop; the pointer is next brought to zero, and held there while the printing line-key is being pressed; the current thus sent through the printer magnets sets the letter-wheel in position for printing, releases the detent, and forces for-

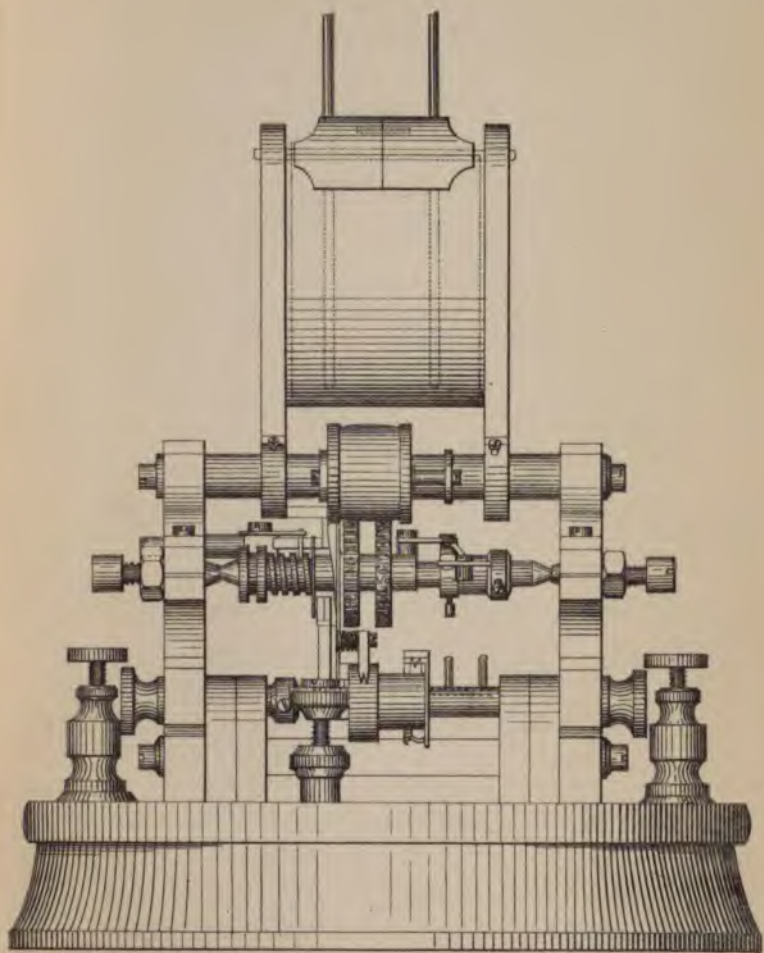



ward blank paper. The message is next proceeded with, the pointer being brought to and held opposite the letters &c., composing it, while the battery current is sent on the printer line.

For more than one circuit relays only are worked by the transmitting apparatus, and the necessary combinations are effected secondarily through them.

Disadvantages of the system.

The chief disadvantages of this system are :—

1st. The burning and disintegration of the relay contact points by the induced discharge from the electro-magnets in circuit, and consequent variation in the force and duration of the impulses.

2nd. The difficulty experienced in sending more than about 600 currents per minute to rotate the type-wheels in consequence of the distance apart at which the relay contacts have to be set when the sparks discharged from the line are of very great intensity.

3rd. The impossibility of avoiding jerks and maintaining a uniform rate of speed for any length of time.

4th. The alteration of the pulsations when transmitted through relays, owing to the inertia both of the mechanical and electro-magnetical parts.

Efforts to Improve Instruments.

Some efforts were made to improve the working of these instruments, but with only partial success; an automatic transmitter, capable of working up to what was considered the high speed of 18 revolutions per minute, was made, and used for a time, but we rarely got up to that speed, partly on account of having to work to suit some badly constructed instruments and partly from defective insulation and irregular conductivity of the lines.

A better transmitter to work up to 22 revolutions per minute was subsequently made, which has been in use to work a few instruments on a single line for some years, but this improvement in speed was not sufficient, and very little more could be expected without a change of construction.

Having been requested to improve the instrument, so that it

might fulfil the requirements of the Exchange Telegraph Company, I carefully considered the electrical and mechanical conditions necessary for rapid and correct action, and at the same time endeavoured to retain all the advantages obtained by the use of two small type-wheels instead of one large one, and the other ingenious contrivances of the original instrument.

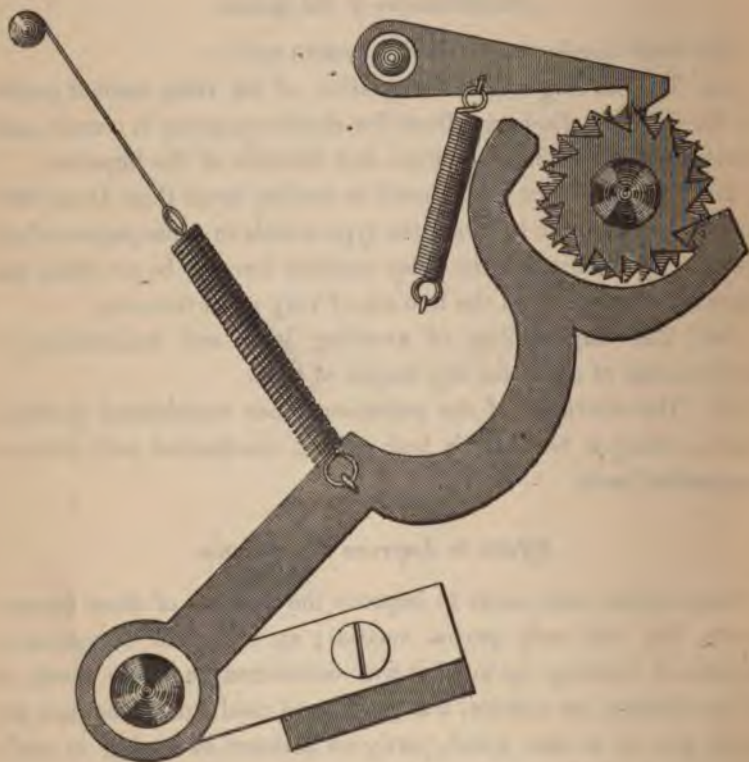

Fig. 4.

The first and most important step towards the desired result was to halve the number of teeth on the propellant wheel, and thus cause the downward movement of the pallets to move a whole letter forward and the upward movement another. The printing with this arrangement must be done sometimes while the current is on

the type-line. In the other system (except when worked on a single wire) it is always done when no current is on the type-line.

The propellant already described was not adapted for rotating the type-wheels at the higher speed on account of the increased momentum causing it to trip, and also because of the increased movement over the larger teeth.

A form of propellant and check is used (fig. 4) by which the type-wheels are locked in position, except when released by the movement of the pallets. This arrangement answers perfectly, and requires less movement of the pallets and less battery power than the form used in the slow instruments.

The type-wheels (fig. 2) are each made from a single piece of cast steel, all unnecessary metal being removed. To diminish friction, the slide tube (D, fig. 2) which carries them is bored out so as to touch the propellant axis only at its ends. It is made of gun-metal, and slides on burnished steel without oil.

The inking-roller is arranged to press very lightly on the type-wheels in order not to impede their rotation.

The pivot-holes for the type axis are bushed with bell-metal; if made of common brass they are liable to become oval from the pressure of the pallets.

After these alterations, and some others to insure the permanence of the adjustments and facilitate the entry of the paper, it became necessary to try to improve the electro-magnets.

Electro-magnets.

To obtain great speed and a fair return of work for the battery force employed, are results which are to some extent antagonistic. It has been shown by various experimenters, and it is observable in practice, that electro-magnets with cores which are short in proportion to their diameter act very much more rapidly than those with long slender cores.

The use of metal cheeks or bobbins to contain the wire will cause retardation by the circulation of induced currents in them. Bad insulation of the wire of the coil will sometimes produce the same effect, and with instruments of this class cause very much

trouble. The length of wire bridged over will exercise a damping influence equal to that of a copper tube containing the same quantity of metal.

Larger masses of soft iron for the fixed or movable armatures than are at present used for the electro-magnets would give a greater ultimate power—but the immediate effect would be less, the magnetic impregnation being perceptibly slower with an increase over the quantity now used. On the other hand, further diminution of the size of the armatures would prevent the acquisition of sufficient attractive force and necessitate an increase of battery.

Elongation of the poles beyond the bobbin and the attachment of pieces of iron to increase their surface exercise a retarding influence and are therefore avoided.

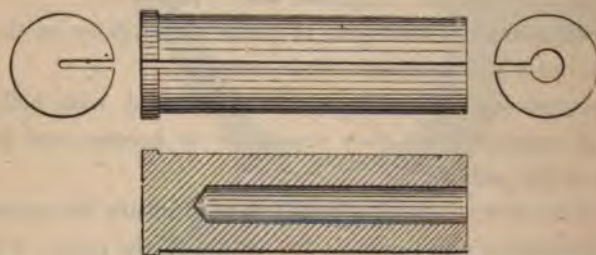

Fig. 5.

The electro-magnet cores are made from a very pure description of charcoal iron manufactured in small quantities in Switzerland; one-third of their diameter is bored out from the bottom to within a short distance of the poles (fig. 5). They are then slit longitudinally and annealed without contact with the air. The effect of removing such a cylinder of iron from the centre of the core is to considerably increase in promptitude the movement of the pallets. I was at first inclined to believe that this form of core would give a diminished permanent effect, but find that the contrary is the case—and it appears that magnets of this form, so far as I have seen, are more effective than those furnished with solid cores except only

when approaching saturation. They can be used advantageously in high-speed telegraphic instruments. The escapement pallets of a type-printing instrument have been correctly vibrated by them at the rate of 2,700 currents (reversals) per minute, although the weight to be moved and the space through which it had to move were great.

Flat armatures are used, numerous experiments having shown them to be best. Similar magnetic rays cannot easily be concentrated by convergence like those of heat or light; therefore lenticular or conical faces to the magnet poles or armatures are useless or worse. (Some instruments which were fitted with such magnets always distinguished themselves by their sluggishness, and were rejected by the inspectors as having "weak" magnets.)

Although some extra turns of wire could be got into the electro-magnet bobbins if wound irregularly, we always wind in layers—by this means a single derivation can only affect two layers of wire at the most.

The copper wire employed is of the best quality obtainable and thinly covered with silk. If of bad quality, or too thickly covered with silk, the estimated number of turns and resistance cannot be put into the space at command.

Method of Working the Improved Instruments.

The instruments, constructed as described, could be readily worked direct from a crank transmitter, at the rate of 70 revolutions of the type-wheels per minute (1,050 currents), but when relays worked by an automatic transmitter were employed such a speed with a reasonable amount of battery power was not at first obtainable. The causes of this failure were—

- 1st. Want of power to make firm contacts in the transmitter.
- 2nd. The inertia of the type relay lever and armature.
- 3rd. The want of firmness with which the relays made contact.
- 4th. The oxidation of the contact points; and
- 5th. Some retarding influences which were removed by a slight change of construction of the relays.

I will explain how the first difficulty was overcome when describing the transmitter.

The second was removed by reducing the distance at which the contact-points were placed from each other; but, simple as this appears, it can only be made possible by arranging a condenser to receive from, and to return through the line, a portion of the induced discharge from the electro-magnets at every opening of the relay contacts. This discharge being in the opposite direction to the battery current completely cuts off the flaming discharge, which would otherwise pass between the contacts and keep the battery current constantly flowing. In addition to this it promptly demagnetises the electro-magnets.

A portion of the discharge from the condenser escapes disruptively between the points and keeps them perfectly clean and bright.

The want of firmness with which the relay contacts are made cannot well be entirely remedied without making use of inconveniently stiff spring contacts. Lessening the play of the lever of the type relay, however, diminishes the tendency to recoil, and the printer-contacts are made firmly enough if a long spiral adjusting spring, wound in such a manner that the rapidly-increasing attractive force of the magnet may not be counteracted by a corresponding increase in the tension of the spring, be employed.

Without condensers the platinum contact piece in connection with the carbon of the battery grows to a sharp point, which usually makes, and enters, a corresponding hole in the opposite contact piece. The deposited metal is not homogeneous, and, if left for more than a few hours' continuous work, is liable to cause the points to stick together.

When condensers are applied the carbon contact grows uniformly by a deposit from the other point, and if both face each other well, and the pivots are true, will maintain their relative positions for some days. The deposited metal is very much harder than the wire from which it is taken.

After having caused the contact makers of the transmitters and relays to act firmly, and keep clean, a considerable increase of

speed was possible; trials indoors succeeded perfectly, and an instrument was placed out on a line in a subscriber's office, but, in spite of every care having been taken to make it work successfully, we soon received a message that the instrument was out of order. On examination, the record was, however, found to be perfect, and it appeared that the subscriber, without consulting the tape, had erroneously concluded from the unusual speed of printing that something was wrong.

The type-wheels were revolving at about 60 revolutions per minute, and about 150 prints per minute were made against a maximum of 50 by the hand transmitter with the original instrument.

We now always work at 48 revolutions per minute, because that speed most nearly corresponds to the rate at which we receive the matter from the Morse instrument. The operator sending on the latter has, even at this reduced speed, to maintain a fair rate to prevent being overtaken.

The whole system, with the exception of one circuit, was furnished, with the improved instruments, about four years ago, and has worked satisfactorily ever since.

Transmitting Apparatus.

The transmitters, one of which works 250 instruments, and is capable of working 1,200 (or more if necessary), have been constantly at work, and are very uniform in action.

The transmitter, fig. 6 (with a piano keyboard of 31 keys), consists of a commutator geared into a train of wheels driven by a weight, which is suspended by an endless chain. The commutator is a disc A, fig. 8, unequally divided on its periphery into 30 spaces and projections. The spaces are slightly less than one-third of the length of the projections. The end of a lever B, held by a spring on to the circumference of the disc, rises over the projections and falls into the spaces during the revolution of the latter, and causes the upper part of the lever to make and break contact with a spring, thereby connecting a battery with the relays which close the type circuits. 30 radial-pins ranged spirally round a shaft C, fig. 8, pass

at irregular intervals over a rectilinear range of stops actuated by the finger-keys. This shaft, although unconnected with the tram, obtains its motion from the disc by means of a short spring. It is always kept in advance of the disc while running by an interval of space sufficient to admit of the last operation of the type contact-maker taking effect before the printer circuit is closed. The latter operation is effected by a pin on the disc overtaking and pressing a contact-spring on the shaft each time the train is stopped by a finger-key.

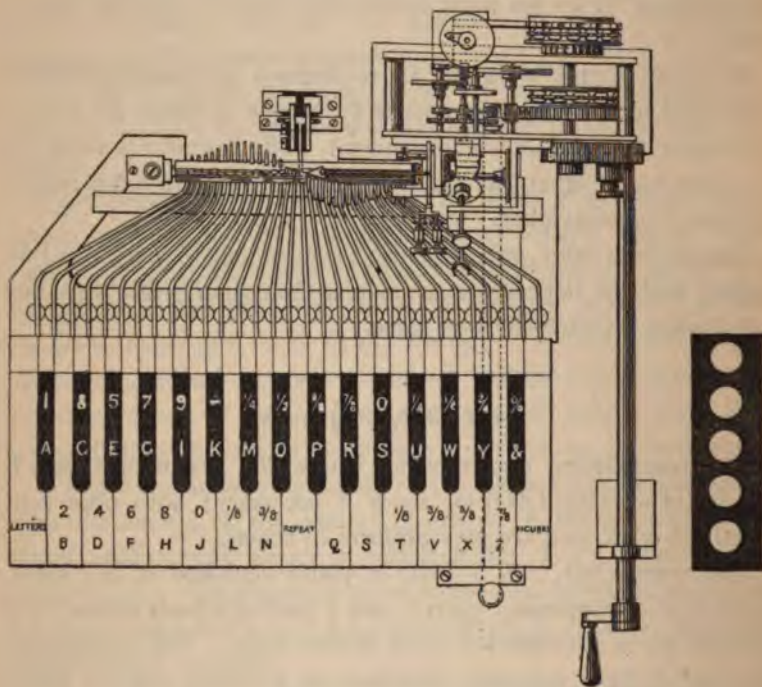

Fig. 6.

The object of the irregularity in the spaces between the radial pins is to give the maximum time possible for the magnetisation of the type-revolving electro-magnets. A very much shorter interval is allowed between the cessation of the current, and consequent release of the pallets (or type armature), and the putting on of the

printing current. Greater speed is attainable by this means than if the printing circuit were closed at equal intervals after the commencement and cessation of the type current.

Three contact points are used in the transmitter, viz., one for the type pulsations, one for the printer circuit, and one to interrupt the latter when a repetition of any character is necessary.

This is a convenient number of contacts; a transmitter, not now in use, which is shown on the table, has 63 contacts.

In order that the intermittent currents sent to revolve the type-wheels may be perfectly uniform in duration, a form of adjustable governor is employed (fig. 7). When at rest it has but little inertia, and, assisted by the small spring on the pin-shaft which is wound slightly each time the train is stopped, allows the commutator to start at full speed and run uniformly.



Fig. 7.

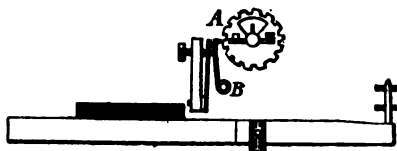
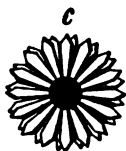

Fig. 8.



To prevent the splitting of each current into many, by the vibration of the contact-spring, consequent upon the concussion of the lever on the projections of the revolving disc, the moving parts are made very light, adjusted to move through the least possible space, and held firmly by springs. The contact-points rub slightly for one-fourth of the time of contact and then remain steadily in connection until the lever falls into a space in the disc A, fig. 8.

The shaft when stopped by keys would recoil and make the printer-contact insecure, but for a ratchet-wheel C with three pawls, which divide its circumference into about 540 parts, one of which is the extent of the utmost backward movement possible.

The whole instrument is fastened to a rigid base of metal to preserve the relative positions of the parts.

The same instrument may be arranged to work on a single line by furnishing it with a weight to act as a motor through a train of wheels, and by causing the currents to be directed alternately through the type escapement magnets and the printer magnet by an automatic switch.

Such a system would only be useful in cases where the rent or cost of wires was a consideration. It is much more complicated and costly than the one I have been describing. It can be worked from the same transmitter as the two wire instruments, and if necessary without a motor.

Batteries.

The batteries we employ in working the printing instrument I have already described in remarks I made some time ago, when Mr. Sivewright's paper on batteries was being discussed. They are like Bunsen's, except that a solution of chromic and sulphuric acids, made from bichromate potash, is used in the place of nitric acid. They require to be charged three times a week for our work.

Some economy of bichromate solution, and greater constancy, are obtained by reversing the relative positions of the zinc and carbon elements.

It will readily be understood that automatic instruments of this description, working almost entirely without supervision, or the occasional adjustment to suit the varying circumstances, which other recording telegraphic instruments receive, must depend in a great measure upon the uniformity of the force which causes every movement. Too strong a current will cause rapid exhaustion of the battery, and one too weak will not revolve the type-wheels with certainty or make a good impression on the paper.

Although well adapted for our ordinary work, the batteries would require modification if worked continuously day and night. They begin to diminish in power to an inconvenient extent, owing to the reduction of the liquid in the vicinity of the plates after transmitting about 900 words, but recover nearly full force after fifteen minutes' rest.

The printing causes more exhaustion than the type revolving.

The quantity of current passing when the type-wheels are being revolved is but one-fourth of that which passes when the printing circuit is closed while the type-wheels are being held in position for printing. (This quantity was determined by the movement of a needle placed 20 feet from the battery wires.)

The induced discharge on making battery circuit being of much greater potential than that of the battery, circulates for some time. This potential increases more rapidly than the battery for any increased length of circuit, and diminishes the duration of the effective current considerably. On this account no exact allowance of battery can be made to produce the same effect upon lines of equal resistance with different numbers of electro-magnets in circuit.

Electro-magnetic Disturbance.

For instance a line of 90 ohms resistance, made up of 78 ohms line and 12 ohms in electro-magnets, will work as well with twenty-four cells as a line of equal resistance made up of 30 ohms line and 60 ohms instruments will with 30 cells.

Judging from the appearance of the type-wheels in revolving, the currents are diminished from one-sixteenth to one-twenty-fourth of a second in duration on a circuit of twenty instruments (no allowance being made for the time the pallets armature takes to respond).

On short circuits, including not more than six instruments, there is very little apparent difference between the movement of the pallets and that of the relays.

Battery Power for Ordinary Instruments.

One cell is allowed for every 3 ohms resistance, and the number varied to suit the circumstances. The internal resistance of each cell is from 0.25 to 0.3 ohm. The provision for a quantity equal to .5 Webers in two lines simultaneously with the above-mentioned resistance is therefore ample.

The liquid from the batteries is not nearly exhausted when thrown away; it would serve our purpose for some time longer if used in batteries having more carbon surface exposed, and after-

wards furnish sufficient depolarisation* for a battery to work an ordinary line of telegraph for a few months.

The zinc plates require to be amalgamated about once in six weeks. The effect of the mercury appears to be to render the surface of the plate highly electro-positive by causing the adhesion or absorption of hydrogen. After long-continued action the plates in some parts present a spongy appearance, and dissolve steadily, although the affected part will frequently be found, if rubbed slightly, to be full of mercury.

In spite of the fact that we do not reduce the solution used in this battery to the utmost, it is still by far the cheapest form of liquid battery we have yet tried, and I believe that, if carefully constructed, they will be found of great use in ordinary telegraphy for faulty or submarine lines. Their low internal resistance compared with the Minotto battery would remove resistance, which probably acts as a length of land-line would, and prevents a cable becoming promptly charged.

Forty ten-cell telegraphic Daniells' batteries, having 6 ohms per cell internal resistance, would have to be connected together quantitatively to produce a current equal to that furnished by five of the bichromate cells. The whole of the batteries at our central office could not be represented by less than 48,000 telegraphic Daniell's.

The quantity of sulphate of copper one pint of the bichromate solution will reduce to metallic copper, &c. is 2,248 grains.

The potential is increased by cold weather but the batteries are more rapidly exhausted. In addition, some loss is caused by the leakage over the dew and minute drops of acid thrown up on to the vessels by the hydrogen bubbles from the zinc.

Insulation.

In the city of London good insulation without using cables is very difficult to secure. Insulators scarcely deserve the name—they become coated inside and out with a mixture of soot, acid, and tar, which conducts very well when on ebonite insulators in

* The term depolarisation does not appear sufficiently comprehensive. The reduction of chromic acid to chromic oxide and water takes place with an evolution of heat, which adds considerably to the electromotive force.

damp weather. The inverted cups are not of much use on this account. Our wires are insulated from the sides of houses by various forms of insulators according to circumstances. Specimens will be found on the table which will explain themselves.

The character of the insulation must be different to that which is sufficient for ordinary telegraph lines. Silk does not insulate if the wire it covers bridges over more than half-a-dozen layers in the electro-magnet, and is of no service whatever for insulating between the two lines. A fault in an instrument caused by such a defect will sometimes cause an interruption although only a few particles of charred silk convey the discharge and the lines appear perfect to ordinary testing. In such cases the locality has to be discovered by testing with sparks. The condensers have to be carefully made to resist perforation.

Some effects of the Spark discharged from Electro-Magnets.

The spark discharge from the line has the property of fusing contact-points together while opening. This effect is easily produced by the sudden application of a condenser of three or four times the usual capacity to the two contacts. This fusion is caused by the line discharge and not by an accumulation from the battery; the points must therefore open before the condenser can become charged, and the latter discharge some portion of its charge across the contacts in the short interval of time between their opening and rising an almost inappreciable distance.

The time occupied by the charging and discharging of the condensers is so short that a scarcely perceptible effect is produced on a galvanometer introduced into the circuit (except it be specially arranged), and none whatever on a voltameter.

As usual with electricity of high tension, this will not be regulated by the usual laws, and, instead of passing through a spiral conductor of 2 inches of No. 30 or 24 copper wire, will go preferably by a more direct route offering some millions of megohms resistance, made up of two thicknesses of lacquer and an air space.

Faults.

The vibration of the propellant pallets in those instruments with binding screws, which are unprovided with set or lock nuts, sometimes loosens the wire, and causes either partial or complete loss of continuity. In a number of cases, when the lesser fault has been discovered in testing before the commencement of business, it has not caused the slightest inconvenience. Recently a type-line increased to more than double its normal resistance, but worked perfectly well, without missing one out of more than 4,000 signals. Had the extra resistance been caused by a length of wire, working would have been impossible. The fault remained on for two days.

The greater fault can sometimes be removed by causing the spark from a good line to pass into the faulty one, but of course the binding-screw is not tightened by this process, and unless the locality be discovered the same fault may appear again.

A troublesome intermittent contact in an instrument can sometimes be made permanent by the same means.

Our lines being short, and a daily record of their resistances kept, no difficulty is experienced in finding the distance of even a slight contact fault by using one of the wires as a battery wire and adding resistance to the shorter side of the other to place the fault in the centre of the resistance.

The locality of a contact fault cannot always be judged of from the appearance of the printing on the tape; if it be a metallic connection near the sending-station the printing will often be the same from instruments on each side of the fault, that is, the alternate letters of the alphabet, beginning at B, will be printed; the only difference will be in the length of tape paid out.

A fault which occurred on the wires leading to the first on a circuit of about sixteen instruments did not affect the first three instruments at all, but commenced to appear faintly on the fourth and each succeeding one more strongly, until a little beyond the middle instrument, when the effects of the contact gradually diminished in the same order, and did not show on the last two.

These instruments were all alike, and as nearly as possible in similar adjustment.

The derangement of one instrument on a line of four or less will cause the pulsations to be so much disturbed that the other instruments might work badly also. If the good instruments be adjusted to work in spite of the irregularity of the pulsations they will not work when the defective instrument is set right.

This makes it rather awkward for a new hand who tries to improve the correctly-adjusted instruments first. He may bring affairs into an extremely perfect state of disorganisation, and then the only remedy is to tighten all the armature springs until the electro-magnets are only just able to attract them. The springs must next be gradually slackened by about the same quantity each, during several visits, until the pallets work in the usual manner.

A long circuit was in this state on one occasion, owing to an instrument inspector having tinkered up a number of instruments out of doors in trying to remedy a slight defect in working, which he should have known was in the apparatus at the sending-station.

Very little care is necessary to prevent this difficulty ever arising.

The effect of allowing a number of armatures on a circuit to stick, is to increase the magnetic inertia and cause great attenuation and irregularity in the currents. The facility with which the armatures move exercises considerable influence over the time the currents require to attain their maximum. When the springs are tight the retardation is less than when they are slack.

Capabilities of the Instruments.

The work these instruments are capable of performing may be judged of from the following data:—

The average number of currents sent on the type-line for each print is	4.996
The number of letters which pass over the impression-pad for each print is	9.992
The number of letters printed per revolution of the type-wheel is	3.02

The minimum weight required to rotate the type-wheels at the proper speed is 2,405 grains through .0345 inches per letter. Therefore if this part of the mechanism were worked by a train of

clockwork and a weight as a motor, 45·98lbs. would have to fall one foot at least for the minimum day's work.

One day the currents on the type and printer lines were counted, with the following result:—

Number of prints	4,660
Number of currents on type-line	23,284
Length of paper paid out	70 feet.

This matter consisted of 332 Stock Exchange quotations. Our average day's work is over 500. Sometimes more than 700 are sent, or a number equivalent to about 1,600 words of five letters and one space.

The quantity of paper used in a year is about 2,200 miles. The same matter printed on the Morse would require over 9,000 miles of tape.

Comparative Speed.

As regards the speed of this apparatus compared with some of the instruments in use for similar purposes in the United States, I am unable to give any data up to the present time, but one of the directors of the Exchange Telegraph Company, when on a visit to New York in the beginning of 1874, obtained several timed specimens of telegraphic printing. The fastest were from the following instruments:—

Manhattan	8 mins.
Edison (cotton)	30 „
Phelps	30 „

We copied the first in 3 minutes, the second in 15½ minutes, and the third in 35 minutes, upon our instrument.

The Manhattan slip was taken from an instrument fixed in a broker's office in New York, and was a fair example of the usual performance of that instrument.

The Edison (cotton) tape was printed by the officials of the Gold and Stock Company after hours at the best speed; so also was the Phelps' specimen, but on account of the matter in it being unintelligible, and consisting mainly of long strings of letters and figures with few spaces, the operator in copying could not get along *fairly*.

Our usual speed of 48 revolutions of the type-wheel per minute was maintained in this trial.

The Manhattan instrument—one of which is shown—is a single-wire instrument, whose type-wheel is driven by a weight. The Phelps has two springs to act as motors, electricity being only employed to actuate the escapements.

In conclusion, I believe that for economy of construction, simplicity, and efficiency, this apparatus is for the purposes for which it is designed at present unequalled.

An instrument is on the table which has been at work for two years without repair. During this time it has printed about 20 miles of tape.

The PRESIDENT: I need hardly ask whether it is the pleasure of the Society to return their cordial thanks to Mr. Higgins for his very interesting account of the type-printing machine, and the improvements which have been effected in it. No doubt there are many points of interest which will elicit observations, and there may be questions to ask; but, in accordance with the arrangement agreed upon, we must return to the paper read on the occasion of the last meeting, and devote the remaining portion of the evening to any points which gentlemen wish to bring forward with reference to Mr. Treuenfeld's paper on Fire Telegraphs. A short account has been sent to the Society of the Autokinetic Fire Telegraph system, which I will ask the Secretary to read. This will no doubt be desired by some members, because on the last occasion explanations of this system were given which were perhaps not so clear as many would desire; and, as other systems were also described, the members will wish to be made acquainted with this system also.

THE AUTOKINETIC TELEGRAPH.

The autokinetic telegraph system claims as its advantages—

1. An automatic method of signalling from any one point to any other point.
2. That in order to transmit a message it is merely necessary to

set the instrument to the position required for that purpose ; when, whether the wire is at the moment occupied or not, the apparatus will in turn discharge itself, and in so doing cause the required message to be registered at the receiving station.

3. The impossibility of interruption from any other alarm or signalling apparatus in circuit.

4. The employment of an open circuit by which means the consumption of battery power, which attaches to the closed circuit or constant current system, is avoided ; and, what is still more important, the deterioration of underground wires is not incurred.

Two wires are employed, one of which, A, may be termed the *starting wire*; and the other, B, the *recording wire*.

The apparatus consists of—

Firstly.—An automatic receiving apparatus, which is so constructed that on being set in motion it interrupts the starting wire and establishes the circuit with the recording wire ;

And secondly.—Of the sending apparatus, which may be placed within iron pillars, in other convenient positions in the streets, or within doors.

The *Receiving apparatus* consists,

a. Of a Morse inking apparatus, by which the signal received from the sending instrument is recorded on the usual paper-ribbon provided for the purpose. This portion of the instrument is simply a Morse inker with self-starting arrangement.

b. A bell, in local circuit, which is put in motion by a relay arrangement within the Morse.

c. An automatic commutator, the object of which is to regulate the arrangement of the wires by means of which the possibility of interruption to the message being signalled is prevented. This instrument consists of a train of wheels driven by a spring, which is wound up similarly to a Morse inker. The mechanism is held in check by a small detent, *b*, fixed to the armature of the coils, *c*, which, when raised, releases a pinion carrying a contact-piece *d*, which ordinarily rests upon, and makes contact with, a spring *e*. On *b* being raised, *d* revolves, and in doing so breaks the line A circuit, which is completed by means of the coils *c*, the spring *e*, and the contact-piece *d*.

STEM.

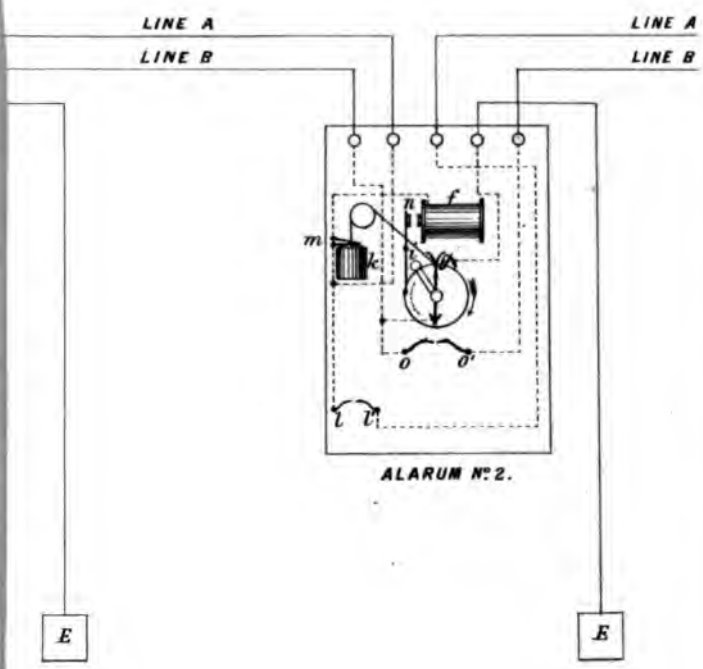



d. A key, F, which is of the ordinary single-current-key form.

The method by which the several parts are connected is shown in the figure. Two batteries are required; one, consisting of one or two cells only, for the bell; and another, the power of which is regulated by the length of the circuit, for signalling.

The *alarum* or signalling instrument consists of a pair of coils *f*, a rotating needle or indicator *g*, a small drum *h*, to the axis of which is fixed a handle or winch *i*, by which it is rotated in the direction of the arrow. On imparting to it this motion the weight *k* is raised by means of a cord attached to it in connection with the drum *h*. The bottom of this weight is platinised so as to form contact with two springs *l*, *l'*, seen beneath it, and so to complete the circuit between the two wires to which the springs are attached. If the connections shown in the figure are traced, it will be seen that these springs connect the *in* and the *out* wires of the line-wire A. The weight, therefore, when in this position cuts the coils *f* out of circuit, and thereby prevents their being operated by any passing current so long as the weight is as represented at alarum No. 1.

But now, if the winch *i* be wound around, the weight will be raised as shown at alarum 2. The springs *l* *l'* will now be disconnected and the circuit of line A will be broken; but, on the weight being fully raised, the springs *m* will be brought into contact and that portion of the line A connected with the receiving station will be put in connection with the coils *f*, the other end of which is to earth. If a current now flows through the coils, the armature *n* will be attracted and the detent at its extremity will release the drum *h*, which will revolve under the influence of the weight *k*, rotating with it the needle *g*, both in a direction opposite to that indicated by the arrow. The needle in revolving passes over, and makes contact with, certain fixed metal projections in the face of its dial which represent numbers or letters of the Morse alphabet. The line B is connected to the needle, and the metal studs to the earth. The needle, therefore, as it rotates, makes and breaks the line B circuit according to the formation of the metal studs. By this means the message is sent, but the complete action for the transmission of a message will be traced further on.

The needle *g* when in its normal position rests upon two studs or springs *O O'*, by which means the line B is carried through the instrument in the same manner as is the line A, by the springs *ll'* in conjunction with the weight *k*. When in this position the needle is free from all contact except at *O O'*.

It may now perhaps be as well to trace the complete transaction comprised within the sending of a signal, and to observe its action upon the other portions of the apparatus which may be said not to be in use at the moment. We will therefore suppose alarm No. 2 to be set in motion. The winch *i* is wound around to the position shown. The wire A is by this means broken at *ll'*. The springs *m* are then joined by the weight being drawn up against them. This places that portion of the line A in connection with the receiving station in circuit with the coils *f*. A current now flows from the battery at the receiving station through the terminal 3 to the point 5, where it has two roads open to it—one through the commutator to line A and the other through the coils A of the Morse to line B, the latter of which is for the instant disconnected. Line A has been put to earth at alarm 2. The instant it is put to earth the current discharges the commutator and the detent *b* is released; the contact piece leaves the spring *e*, and the line wire A is then broken at *e*. At the same instant of time the armature *n* of alarm No. 2 has been attracted, and the drum *h*, set free from the detent attached to *n*, now revolves, carrying with it the needle *g*, making and breaking contact with line B as previously described. The weight *k* now returns to its normal position and the needle or indicator *g* to its position of rest. By the former line A is restored, and by the latter line B.

Now it will have been observed that the currents traversing either wire can have had no influence over any other alarm in circuit, for, if unset, the instruments will have been cut out of circuit, and, if set, they will have been held in that position pending the completion of the line A circuit at *e*.

Suppose, now, that alarm No. 1 is set at the moment alarm No. 2 is started, the springs *m* will be brought into contact, and the wire A put to earth; but this wire is disconnected at *e*. The weight therefore remains suspended, holding the springs *m* in con-

tact until a current is received, by which the detent on *n* may be released. Line B is all this while through, the needle *g* not having been set in motion. The movement of the automatic commutator is synchronous with that of the needle *f* of either alarm, and thus, when alarm No. 2 has done its work and finished its message, the commutator will have also returned to its normal position and restored line A circuit. This is no sooner done than the current again passes through it, again starts it, and releases *n* at alarm No. 1, which now, in its turn, sends its message.

Assuming now that there are 20 such alarms in circuit, and that No. 10 is first set, and that during the moment it is working Nos. 17, 3, 12, and 5 are set all at once. No. 10 would be the first to deliver its message; then the others in their order of position reckoned from the receiving station, viz. No. 3 first, then 5, then 12, and finally 17.

There is, it will be observed, a necessary synchronism between the time it takes to record the message, rotate the needle, and that in which the automatic commutator has to revolve or complete its circuit.

The apparatus is provided with various mechanical arrangements for altering the characters of the signal, and controlling its direction; also for enabling an experienced operator to communicate from the alarm station to the receiving station other than the stereotyped message. To effect this the winch *i* is so arranged that it can be used as a key, and so employed to make any signal required.

The PRESIDENT: I believe Mr. Truenfeld desires to make some additional remarks.

MR. TREUFELD: With the kind permission of the Council of the Society I have had copies of the paper now before you distributed to the chiefs of the Fire Brigades, who favoured me with data for the tables of my paper, as well as to some other gentlemen connected with insurance companies and statistical researches. These copies sent were accompanied with invitations to furnish me with further points on the subject of "fire telegraphy," with the view to bring such fresh arguments before this Society.

The additional information thus obtained is far too lengthy to be

laid before you *in extenso*; therefore, I have formed a short but complete extract, which, with your kind permission, I will now read.

To my great satisfaction I am able to state that all my informants unanimously agree "that fire telegraphs reduce the time between the discovery of a fire and the appearance of the Brigade on the spot." Now, gentlemen, this affirmation, coming from a vast number of professional Fire Brigade men of most undoubted judgment, we certainly must consider an irrefutable fact, and regard it as the foundation-stone of fire-telegraphy.

I must not omit to mention the opinion of the chief of the largest towns in Great Britain, who says: "There can be no two opinions of the advantage of telegraphy. I have no hesitation in saying that it has been the means of saving many lives at fires, and of preventing a large amount of property from being destroyed by fire, and therefore considerably reducing the per-centage of the number of serious fires.

"At the same time we have in our experience far too many instances of its being found out of order when required. Such being the case, it has its disadvantages as well as its advantages. Many a precious moment has been lost through defective instruments."

I need not say that all Telegraph Engineers will disagree with this objection, and the alleged disadvantage as explained by my informant. Fire Telegraph lines and instruments must no more be out of order than Railway Block Telegraphs; and that the latter are seldom, if ever, out of order we all know very well. From what we have heard and seen in this room, I fully trust that the reliability of the Automatic Telegraph has fairly been proved, and that the permanent current system will detect at once any interruption, should such take place.

The bad reputation into which the otherwise well-appreciated Fire Telegraph fell in the opinion of the above officer can very easily be explained. The Fire Telegraph at his command is, as in most other British towns, placed in the hands of three departments, viz. the Fire Brigade, the Police, and the Post Office. The lines are chiefly overhead or intermixed with Post Office underground

wires, and the station instruments are exclusively dial apparatus. This, unfortunately for the good reputation of Fire Telegraphs, is a combination, of which every item is decidedly subject to become "out of order" and to cause the "loss of many a precious moment, when required."

Judging from numerous official Fire Brigade and Police reports at hand, it is evident that the opinion becomes more and more predominant, that a well-organised fire telegraph is the *sine qua non* for immediate succour, and it is highly satisfactory to see one of the most eminent chiefs of Fire Brigade departments, Mr. Robert Ingram, in Dublin taking the first step in the right direction by recommending in January of this year in his annual report of 1876 the adoption of the automatic fire telegraph system in the following terms:—"I would recommend that at different points of the city fire-alarm telegraphs should be established by means of boxes placed in various districts, also in police and railway stations and public buildings, the key of which could be given to police constables and respectable citizens possessing property in the district, so that on perceiving a fire they could at once communicate with the chief fire station. By means of a proper fire-telegraph system a vast amount of property might be saved."

I now come to the question, whether *there is any danger of the automatic fire telegraph signals being sent simultaneously on the same wire, and thus liable to run together and efface each other.* This question was only a few months ago rather vividly ventilated in the columns of the Telegraphic Journal between one of the Commissionaires of the Autokinetic Telegraph, Mr. A. M. Moir, and the Managing Director of the Exchange Telegraph Company, Mr. Henry Davies. The former suggested the possibility of interruptions occurring through simultaneous sending; the opinion of the latter, based on extensive experience with the actual working of the automatic fire-telegraph in America was, "that no inconvenience whatever is experienced in practice from this cause."

I always thought Mr. Davies's opinion to be the correct one, at least as long as the telegraph communication is limited to the transmission of fire brigade messages only, and I should have considered the question decided, had not some of my informants again

raised doubts about this question. In reply to those doubts I would simply say: I have now in my possession three official reports from the chiefs of the Frankfort, Amsterdam, and Hamburg Fire Telegraphs, who unanimously agree that *not a single instance has occurred in which alarm signals destroyed each other through simultaneous sending.*

Cases however have happened in which alarm signals were sent from two annunciators "partly at the same time," but in all cases, owing to the fact that the annunciator repeats each signal from six to twelve times, only the end of the first series and the beginning of the second became confused, which did *not* prevent either signal from being fully understood.

In the former table of the "Fires in Stettin" I have shown that the greater number of fires were extinguished in their infancy by the speedy arrival of the brigade. That table also showed the tendency of fires to increase from "small fires" to "middle fires," if not extinguished at the outbreak.

This fact, which strongly advises the adoption of fire-telegraphy, is more clearly seen in a table taken from last year's report of the Bremen Fire Brigade, in which the fires are grouped according to the time the brigade required to extinguish them, the time counting from the first telegraphic call to the return of the brigade.

FIRES EXTINGUISHED (BREMEN).

YEAR.	Total number of fires.	At arrival of Brigade.	In									
			$\frac{1}{4}$ hour.	$\frac{1}{2}$ hour.	$\frac{3}{4}$ hour.	1 hour.	1 $\frac{1}{4}$ hour.	2 $\frac{1}{4}$ hours	3 hours	4 hours	5 hours	
1876	439	338	15	31	21	14	11	4	2	1	2	

By this table we see that the greatest number were extinguished directly the brigade arrived, then there were only fifteen fires requiring a quarter-of-an-hour for their extinction, and then comes a considerable number of fires which occupy the efforts of the brigade from half-an-hour to one-and-a-half-hour, after which very few fires remain.

This table gives a graphic illustration that, if the brigade cannot

overcome the fire in the first quarter of an hour, then the fire overcomes the brigade during the first hour, until through stratagem and continued efforts the brigade becomes master again.

When compiling the data for the classification of serious and slight fires, I was well aware of the difficulties, or rather impossibilities, of obtaining information based upon the same standard of measurement. Knowing that there is no recognised *unit* by which to classify the seriousness of a fire, I tried to adopt such a unit, viz. "A *serious* fire is to be understood as a fire for the extinction of which more than two engines or reels were required," and I begged my informants to classify their data in accordance with this unit. I nevertheless did not entertain the hope that the statistical tables would reach the perfection of mathematical exactness, which is simply impossible, until a standard unit is recognised and used by the chiefs of the brigades. Notwithstanding this difficulty, I believe that, whatever such unit may be, the results of a new classification would prove very similar to those I have obtained; and, whatever deviations from the standard which I wished my informants to adopt may have entered into the table, such deviations will *not practically* alter the results obtained; also I repeat that they have no claim to mathematical exactness.

Under these circumstances I was quite prepared to hear criticisms such as, "Your tables are very interesting, but not reliable so far as regards the per-centage of serious fires as compared with slight ones. Each superintendent would carry out his own ideas of what he considered a serious fire," &c. &c.

I can only here console myself with the same excuse which a far higher authority in fire statistics, Mr. Cornelius Walford, barrister-at-law, and author of the Insurance Cyclopædia, has introduced in a most elaborate paper on "Fires and Fire Insurance," which he read on the 20th instant before the Statistical Society. Mr. Walford earnestly complains of the difficulty in obtaining from fire departments materials based on uniform standards, and he thinks, that, "where the materials are incomplete and disconnected, we can do no more than make the best of the facts as they stand."

The author is equally correct in his declaration that it "seems strange beyond all power of expression, that the constantly recurring

devastations by fire have never yet sufficiently interested the governments of civilised countries to have caused the adoption of a simple statistical record, if nothing more, of the aggregate annual number of fires, their causes as nearly as can be ascertained, and the amount of property destroyed thereby."

Mr. Walford then suggests the interference of governments to enforce the departments to collect uniform statistics, and he thinks, that, "when the International Statistical Congress shall succeed in convincing the governments of the world that facts are worthy of systematic record, we then may hope for better results."

On this occasion it may perhaps not be inopportune for me to suggest the advantages which would also arise from the formation of a "National Congress of Fire Brigades," which, similar to those on the continent, would meet annually at various towns, where not only improvements in the appliances of the brigades could be brought forward for discussion, but also all questions of administration, practical manœuvres, and statistical records.

There was no intention to localise my observations to any particular country, but to gather information from wherever they were obtainable, and to arrive at a general result regarding the influence of Fire Telegraphs upon the decrease of destruction of property. Two incidents however have occurred since the paper was written which are of too great significance in the literature of "Fire Protection" to be left unnoticed.

The first being the appearance of Captain Shaw's valuable book on "Fire Protection" and the second the paper on "Fires and Fires Insurance," read before the Statistical Society by Mr. Walford, and which I referred to before. These gentlemen are of the highest authority in the practical and theoretical matters of fire protection; but I think both will have to agree with me that their elaborate works *do not* pay that attention to the telegraph which my tables show is due to the electrical apparatus as a powerful means of fire protection. In Captain Shaw's minute and lengthy manual of 342 pages, only half a page is devoted to the telegraphic communication adopted by the brigade of London—a rather primitive system of fire-telegraphy! After this follows two pages of "Rules for the Transmission of Messages," and no more honour

is paid to the electric fluid! Also the plan attached to the book does not convey the idea of great importance being given to telegraphy. It shows the fire-engine stations and telegraph lines, and, if correct, there are parts within the limits of the jurisdiction of the Metropolitan Board of Works which are $2\frac{1}{4}$ miles by direct measurement from the nearest metropolitan fire-engine and fire-telegraph station, whereas no part of the metropolis ought to be more distant than a quarter or half a mile from the means of telegraphic fire communication.

The other authority, Mr. Walford, in a lengthy paper of seventy-eight octavo pages, only suggests in a few lines the adoption of the automatic fire telegraph as "a most excellent means of instantaneous communication through the metropolis."

I have quoted these two instances with the view of illustrating the opinion, that fire telegraphy has *not* received the attention in this country which it enjoys elsewhere; to further corroborate this, I beg to be allowed to mention one more of the many instances at hand.

A letter sent to the Fire Brigade authority of a town of 80,000 inhabitants, asking for statistical data relating to serious fires, was literally answered in the following words: "Sir,—We have no telegraph stations, nor, in fact, a fire brigade. We have hydrants, and those with reels are worked by some of the men employed by the Corporation Water Works."—Signed by the chief of the Corporation. Four letters more, asking for per-centage of serious fires, remained unanswered, which leads one to think that the per-centage of serious fires must be rather high.

The financial value of fire protection may be better conveyed by a few numbers. Professor Anderson Kirkwood estimated, that the extent of inland fire insurance in the United Kingdom in 1872 was £1,900,000,000. The aggregate premiums received by the offices had been estimated at £7,000,000, and are now even higher.

Mr. Walford, at the Statistical Society, put the question:—Have the municipalities of the kingdom generally provided for the protection of lives and property of the inhabitants from fire in a satisfactory—even a reasonably complete—manner in the past, and

are they doing so now? The answer, he says, is but too obvious—they have left these duties to the care of the Insurance Offices.

The paper, gentlemen, has been brought before you with the view to throw a light on the position which Fire Telegraphy bears as a protection of life and property, and with the hope of conveying through this Society the true nature of this position to the authorities entrusted with the provision of such protection.

The PRESIDENT having invited observations from any one present, and obtaining no response, here called upon Mr. Treuenfeld for any final remarks he might desire to make.

Mr. TREUENFELD: There is very little or nothing left for me to add to the paper, but I beg to make a comparison. When a fortification has to be taken by storm, and after having been taken it is found to have been evacuated, I know from experience every one is disappointed. In like manner I felt personally disappointed when I found at the last meeting not a single voice was raised against the facts which I had the pleasure to lay before you. That disappointment has been confirmed by the support I have received, not only from the political and technical, but also from the insurance press, and I can say from the most important of those papers. I think there can be no doubt in all questions touching the public interest and the welfare of the public it is most desirable that such questions should be investigated from all sides, and, so to speak, the other side ought to be shown, and that from every point of view. I should be delighted to see any one step forward to show the other side, if such exists, of the facts which I have had the pleasure to lay before you.

Mr. MONTEFIORE: I would make one observation before putting aside this important matter, and it is this—after reading so admirable a paper, and such a collection of valuable statistics from Mr. Treuenfeld, I wish to suggest, and I do so with the utmost deference, that we should take some steps, for, although we are all well aware of the many advantages and capabilities of ordinary telegraphy, yet we have been informed for the first time of its importance and advantage in case of fires. It appears to me our duty that we should take some steps to make the subject more generally known. We cannot attach too much importance to the statistics that have been

laid before us, showing that where fire telegraphs have been established the average of large fires has been reduced from 21·10 to 4·10, and the results of this system where it is already in operation show the great importance of its being adopted in all large cities. It appears to me desirable that not only should these important facts be acknowledged by ourselves, but that we should, after having had them presented to us in so able a manner by Mr. Treuenfeld, take upon ourselves the duty of passing a resolution that we should bind ourselves to use every effort to educate the public generally and the municipalities all over the kingdom as to the importance and vast saving of property and protection to life which a system of this kind is calculated to afford. I would suggest, therefore, that this Society should take into consideration in what way the valuable statistical information we have had before us can best be made known to the public.

MR. R. K. GRAY: I would make an observation upon this paper, though it is not one of great importance. Mr. Treuenfeld shows by a table of the fires in London, and in one part of his paper says, that within the last ten years serious fires in London have been reduced more than fifty per cent. in spite of the increase of the population; nevertheless 10·5 per cent. of the metropolitan fires are still serious. He then refers to Berlin and says, that in that city the serious fires amount to only 2·82 per cent. By making a fair comparison between London and Berlin, I think it can be shown, that whilst the latter has 2·82 per cent. the former has 5·3 per cent. of serious fires and not 10·5. Berlin has a population of 980,000, or say one-third of that of London, and therefore the fires occurring there in three years should equal those occurring in London in one year. The total number of fires in Berlin during the three years quoted was 2,842; in London the annual average was 1543. By referring to another table, at page 112, where there is given the total number of fires which occurred at various towns before and after the establishment of fire telegraphs, I find, that, whereas the average number of fires before establishment was 680, after the establishment this figure rose to 1512, or more than double. By these it would seem that the greater facilities for communication with the fire stations have increased the registered

number of fires at Berlin by about 100 per cent. It is therefore a fair inference, that, if London were fitted up with such telegraphic communication as Berlin possesses, the 1,543 recorded fires of London would also be increased 100 per cent., although the serious fires, which at present are all recorded, would form no part of this increase. Had Mr. Treuenfeld taken this increase into consideration, his per-centage of serious fires in London would be reduced from 10·5 to 5·25. This not having been done, I think his comparisons misleading.*

Mr. LANGDON: On page 11 (p. 85) of the paper which Mr. Treuenfeld has submitted to the Society, it is stated that the entire system of

* In the following table, deduced from Mr. Treuenfeld's figures, the annual averages before and after the establishing of Fire Telegraphs form a more correct base for comparison as to the value of Fire Telegraphs than the per-centages given at page 112.

Annual Average of Fires before Telegraph.			Annual Average of Fires after Telegraph.		
Town.	Total.	Serious.	Town.	Total.	Serious.
Amsterdam.....	244·1	23·7	Amsterdam	621·3	17·3
Elberfeld	10·4	2·7	Elberfeld	9·5	1·1
Magdeburg.....	51	10	Magdeburg	67·6	4·7
Hamburg	290	18·3	Hamburg	676·3	12
Aix-la-Chapelle...	30	5·5	Aix-la-Chapelle..	31·8	1
Nürnberg	17	7·2	Nürnberg	12·5	4
Frankfort-on-the-Maine	39·2 *	8	Frankfort-on-the-Maine.....	93·3	4·7
	681·7	75·4		1512·3	44·8

[The above has been furnished by Mr. Gray since the reading of Mr. Treuenfeld's paper, and the consequent discussion thereon. In publishing it, it is but right to observe that the establishment of a system of Fire Telegraphs can scarcely be connected with any increase in the number of fires which may occur. The main object of the returns is to show the effect of such a system in reducing the number of those fires classed as *serious*, and this the table furnished by Mr. Gray proves, even with an increase in the total number of fires. There is, moreover, the probability that with a system of Fire Telegraphs, very minor fires, which, did no telegraphic means for announcing them exist would not be reported at all, are, by its agency, announced and so included in the returns.]

Fire Telegraphs at Hamburg has been erected at a cost of £8,028, and is maintained at a yearly expenditure of £80. I would ask what that annual expenditure covers, and whether it embraces the renewal of wires, batteries, and instruments.

Mr. TREUENFELD: The £80 refers to materials used in the maintenance only, not to the employées.

Mr. LANGDON: Practically, I suppose there have been no renewals. Does it cover the wear and tear of instruments?

Mr. TREUENFELD: It refers to insulators or wires replaced and not to wear and tear of instruments.

Mr. LANGDON: I apprehend the £80 a-year would not cover the renewal of wires.

Mr. TREUENFELD: I can only say the returns I have given are compiled from the official tables supplied to me, and I have regarded them as being official and therefore thoroughly reliable, and I have given them as such. It is true, after the establishment of Fire Telegraphs the numbers of calls have been greater, but the number of false alarms is not included in the tables. They are not considered as fires, and the total number of fires has been proved in all towns to increase year by year. I have in my possession a great number of tables from towns, and they almost all show an increase in the number of fires, and the observations of Mr. Gray agree with my data, but I can say I have given the returns as I received them from the official parties.

Mr. R. K. GRAY: I do not wish it to be supposed that I do not regard these facts as possessing the greatest interest, but I should not like it to go forth that the number of serious fires in London is 10·5 per cent. as compared with 2·82 per cent. in Berlin.

Mr. TREUENFELD: The figures are derived from the reports of Captain Shaw as regards the London fires, and from the chief of the Fire Brigade in Berlin as regards that city. I have endeavoured to persuade Captain Shaw to adopt the standard unit with respect to serious fires which obtains in Berlin, but I have not succeeded. In fact there is no standard unit for the measurement of fires in London, and on that question Captain Shaw says he judges of a fire on his own judgment, and rather more by feeling than by any rule. I have distinctly stated that these tables do not claim to be

mathematically exact, but it is in this case as it formerly was with electricity, that a standard unit is absolutely necessary. I have suggested that an International Fire Congress should be held, at which all these and other questions could be ventilated, and a standard unit established with regard to fires. In Germany they have a standard unit already, and when that is done generally throughout Europe we shall obtain more exact results than we have been able to do hitherto.

The PRESIDENT: I gather from Mr. Gray's observations that he considers the comparison of the number of fires in London and Berlin should be made with reference to the number of houses and the extent of the population. Is not that so?

Mr. R. K. GRAY: Yes.

Mr. TREUENFELD: I did not understand it in that way. Population has nothing to do with the per-centage of serious fires, although it may bear upon the total number of fires. In the case of serious fires the only standard we have to go upon at present is that of requiring more than two engines for their extinction. The population has nothing to do with the per-centage of serious fires.

Mr. GRAY: The greater the number of houses, the greater is the liability to fires, although it may not increase the number of serious fires; but to some extent it might do so in London, where the average number of fires annually is about 1,800 of all sorts, as against 900 in Berlin with only one-third the number of houses. Consequently, if there are three times the number of houses we might expect three times the number of fires.

Mr. RISCHE: There is one part which should not be lost sight of with regard to the comparative number of fires in London and Berlin, viz., that, whereas there may be hundreds of small fires in London which are not reported, there is not a case of a chimney being on fire in Berlin which is not reported.

The PRESIDENT: If no other gentleman has any remarks to offer, I have now to announce that at the commencement of the next meeting we will take any discussion that may arise upon Mr. Higgins's paper; after which Mr. Willoughby Smith will read a paper upon Underground Telegraphs.

At the conclusion of the proceedings, on the call of the Presi-

dent, a hearty vote of thanks was accorded Mr. Treuenfeld for his valuable and interesting paper.

The following Associates were transferred to the class of members:—

R. K. Gray.

J. Fletcher.

R. Boteler.

The following candidates were balloted for and duly elected:—

ASSOCIATES :

George Henry Bambridge.

Brackenbury Bayly.

James Henry Beswick.

Albert Brook.

John H. Carson.

Stanley Clarke.

Benjamin W. Colley.

R. G. B. Davids.

F. Davies.

Edward Earle.

F. C. Eymers.

Alfred C. Forshaw.

John W. Fothergill.

Arthur C. Frost.

C. Fulton.

John James Clarence Gavey.

Benjamin James Geo.

F. M. Hannington.

J. James.

G. K. Kirby.

H. S. Langford.

W. Leonard.

Oscar Moll.

E. J. Paterson.

George Squires.

F. O. Thompson.

F. T. Tranfeld.

F. H. White.

C. B. Wood.

When the meeting adjourned.

The Fifty-sixth Ordinary General Meeting was held on Wednesday, the 28th day of March, 1877, Professor ABEL, F.R.S., President, in the chair.

The PRESIDENT: I have to direct the attention of the members of the Society of Telegraph Engineers to what no doubt has already excited their interest, viz., the exhibition here of a very admirable portrait of Sir William Fothergill Cooke. Sir William, as we know, has rendered his name historically immortal in connection with the Electric Telegraph, and we cannot but express our sentiment of gratitude to Mr. Latimer Clark for his kindness to us in presenting to the Society this admirable likeness of so eminent a man as Sir William Fothergill Cooke, who is so generally respected by all connected with telegraph engineering. I therefore beg leave to propose formally that we should award our hearty thanks to Mr. Latimer Clark for this handsome gift to the Society, and I beg to put this proposition from the chair by asking those who approve of it to hold up their hands.

The vote of thanks was carried unanimously by acclamation.

The PRESIDENT: It is a matter of regret to the Council to announce to the members of the Society the resignation by Major Webber of the office of Treasurer. Major Webber has acted in that capacity since the foundation of the Society, and has been most unremitting and zealous in the performance of the duties—the necessarily responsible duties—which attach to this important office. The Council had hoped that Major Webber might have been induced to reconsider his decision, but circumstances render him unable to continue in the office which he has held for so long a period. They had therefore only one duty, viz., with great regret to accept his resignation, and to record what they know to be the feeling of the Society—their high appreciation of Major Webber's services during the period he has discharged the duties of Treasurer of the Society. I have also, with regret, to announce the resignation by Mr. Sivewright of the office of Acting-Secretary of the

Society. We had hoped when Mr. Sivewright, about a year ago, was so good as to take upon himself the duties of Acting-Secretary, that one who in a very brief space of time showed not only great zeal but also great aptitude for the office might have acted permanently for us, but there are reasons which we cannot now discuss which prevent Mr. Sivewright from realising our hopes and wishes in this respect. We shall lose his services shortly, and here again I am sure the Members will concur with the action which the Council have taken—viz., that of recording the thanks of the Society for the valuable services he has rendered and their great regret at having to lose those services so soon. Mr. Langdon, a member of the Society who possesses every qualification for the office, has been so good as to undertake the duties of the post until some permanent arrangements with reference to the secretaryship shall have been decided upon by the Council.

At the conclusion of the last meeting it was announced that we should this evening first take any remarks on the paper read by Mr. Higgins. We shall therefore be happy to hear any observations that members may be disposed to make, or any questions which they may have to put to Mr. Higgins, on the subject.

Mr. LANGDON: There is one point about which I would beg further information. Mr. Higgins on the occasion of our last meeting had some very beautiful instruments joined up on the table, and on one of the circuits he employed a switch arrangement, which, I presume, by altering the character of the current, enabled communications sent—say, in one instance to A B, and in the other to C D—to be kept distinct from each other, so that A B could not receive the news that was sent to C D. That was done, I think, by changing the polarity of the battery current. I presume, therefore, the arrangement could only affect two classes of subscribers, and that, supposing a subscriber of a third class of news came in upon the circuit and required to receive his class of news, this could not be effected without the communication being made known to either one or the other of those receiving the other description of news.

Mr. HIGGINS: The operation in question will only admit of two divisions of the information. An automatic switch, which is simply

a polarised relay, is arranged to shunt or short-circuit the coils of the instrument not required to work. That instrument can be let in again at pleasure by altering the direction of the current.

The PRESIDENT: If no other member has any further observation to offer on Mr. Higgins's paper, I will call upon you to award to that gentleman your thanks for his valuable communication, and the great trouble he has taken to illustrate it by diagrams, and a capital collection of instruments, of which he gave us so lucid and excellent a description.

The vote of thanks was unanimously accorded.

The President then called upon Mr. Willoughby Smith to read his paper on "Underground Telegraphs."

ON UNDERGROUND TELEGRAPHS.

By Mr. WILLOUGHBY SMITH.

In the "Journal of the Telegraph," dated September 1, 1876, under the heading "An interesting Statement," after recapitulating what was done in England and other countries to establish a system of subterranean lines in 1852 and 1853, appears the following statement: "The most experienced telegraph engineers and electricians of all countries in which underground wires have been used are united in the opinion that thus far at least their use has been attended with very unsatisfactory results, and that no method of construction yet devised has maintained underground wires in working order for any length of time."

It occurred to me that such a statement, emanating, as I believe it did, from an American gentleman of high authority on telegraphic matters, should not pass unchallenged. I trust therefore the members of this Society will not consider their time un-

profitably employed in discussing the important question of how, and by what means, can be secured a good and efficient system of subterranean wires. In discussing the subject let us not hesitate to acknowledge how, from want of experience, we have erred in the past, and at the same time show what progress has been made to secure success in the future.

There can be no doubt that the failures of the many wires laid in the years mentioned gave a blow to the underground system, from the effects of which it has not yet recovered. But at the present time, if it is desirable to have a system of underground wires, there are no insurmountable difficulties in the way of establishing such a system on a firm and lasting basis. Those who are well acquainted with the way in which the work was carried out at that time feel no surprise at its early failure.

In 1853 four of the then largest Telegraph Companies were engaged in laying wires covered with gutta-percha from London to most of the largest towns, the number of wires laid by each Company varying from four to ten. In 1853 the system by which the wires were covered with gutta-percha was very imperfect compared with that of the present time, and the means of production totally inadequate to the demand. In June of that year the factory of the Company which supplied nearly all the wires was partially destroyed by fire, which did not tend to improve matters, as each Company, in their anxiety to complete their respective lines during the summer of that year, allowed a laxity of supervision which otherwise would not have taken place.

Coal-tar, naphtha, or other powerful solvents, were used between the separate coverings of the gutta-percha, with a view to insure perfect adhesion, but such solvents were likely to have a very prejudicial effect on the durability of the gutta-percha.

It was to remedy this that I, in 1857, introduced an adhesive insulating compound to be used on the wire, and alternately with each covering of gutta-percha. Time has proved that this compound is admirably adapted to the purpose for which it was invented, and it has been, and still is, used for all wires covered by the Gutta-percha Company. In those days the wires were covered in short lengths, consequently a great number of joints had to be

made, and both electrically and mechanically these joints were far inferior to those of the present day. The joints were not tested separately, but immediately a certain length had been joined up it was wound into coils of stated lengths, immersed in water at no specified temperature, and tested for insulation with 360 cells of the old form of sand battery, and what would now be considered a very dull vertical galvanometer. If the deflections obtained were pretty uniform, and not considered too high, the coils were pronounced good and delivery soon followed.

The conductor principally used was a solid copper wire weighing 63 lbs. per statute mile and known as No. 16 gauge. The copper was not selected for its electrical qualities. In some of the wires supplied about that time I have since found the conductivity to be as low as 18 per cent. of that of pure copper. Want of continuity, caused by the presence of foreign matter in the copper, rottenness from being burnt while annealing, and numerous other causes, were of frequent occurrence.

One Telegraph Company laid some of their wires, without any protection, in a trench dug in the six-foot of a railway, and the other part of their line was laid as follows: Square blocks of creosoted wood, varying in length from 6 to 10 feet, with a groove cut in them sufficiently large to receive ten wires lying parallel to each other, and bound together with two coverings of hemp yarns saturated with tar, were deposited on the bottom of a trench 2 feet deep along the side of the common coach road. After the wires so bound were placed in the groove planks of thin wood were *nailed* over them and the trench filled up. The progress of the work varied according to the nature of the soil, but as a rule from one to two miles were completed per day. During fine weather all appeared to be going on well, but each shower of rain was almost sure to develop faults, and if it rained for any length of time the electrical condition of the wires became alarming. The causes of some of the faults were injuries to the gutta-percha during the process of covering the wires with the hemp, but concealed for a time by the insulating properties of the tar; the gutta-percha becoming softened either by exposure to the sun, or the watchman's fire by *night*; the nails used to fasten the lids of the troughs not being

driven straight, entering the gutta-percha and coming into direct contact with the conductor. (Faults from this cause at length became so numerous that the use of nails had to be discontinued and wire bindings used instead.) Bad joints, wilful cuts from curiosity of idlers, &c., &c.

Another Company laid their wires just as they were received from the manufactory in a very thin deal V-shaped trough in a trench by the road side, while another company taped each wire separately and passed it through a bath of *hot coal tar*, lime, and sand, and then exposed them in coils, suspended on bars of wood, to dry without any protection from the sun, before they were drawn into pipes buried in the ground. In some cases, to protect the wires passing through towns, fragile iron troughs fitted with a moveable cover were used.

The localization of faults by the now known methods were not in existence in those days, consequently the objectionable practice of pricking the wires when in search of faults was resorted to.

In 1861 I introduced what is known as the "wet serving." That is to say, I advocated that the hemp covering, or serving as it is called, of an insulating wire should be saturated with a conducting instead of an insulating fluid. Hitherto the serving of the cores of submarine cables had been saturated with either Coal or Stockholm tar, and in some instances by a mixture of the two combined with tallow. But time proved that the insulating properties of the tar was not only the means of concealing temporarily any injury the gutta-percha might have received, but that the tar had also a very prejudicial effect on the durability of the gutta-percha, especially when exposed to atmospheric influences, as well as reducing its insulating qualities. Since that date tar has been abandoned and the serving of submarine cables has been tanned and applied wet, and the results have been highly satisfactory. But it is still the practice to cover the wires for underground purposes with tape saturated with tar, and it is with a view to induce the discontinuance of the tar that I give the following results of experiments to show the detrimental effects tar has on gutta-percha:—

At the close of the last Session I brought somewhat hurriedly

before the members of this Society a new system of jointing, more especially adapted to subterranean wires. During the session several valuable papers had been read bearing on the subject of joints, and both in the papers and the discussions which followed the reading of them it was admitted that many of the failures in underground wires were attributable to the present defective system of jointing. Mr. Culley, a great authority on the subject, during the discussion which followed the reading of Mr. G. E. Preece's paper on "Underground Telegraphs," said, "If any one could invent a joint for gutta-percha wire which could be done more quickly than the method of uniting the gutta-percha now used, and give us a fair joint and a fair amount of insulation, say ten million ohms resistance, if it could be done quickly so that a man could join up (say) sixty wires per day, it would be a great advantage, and perhaps before we discuss this subject again some member of the Society may hit upon a method. It is one of the things which want to be done." This and similar statements from other members of this Society must be my excuse for intruding as I did at the end of the session on the time of the Society. Of course to test the merits of any system of jointing, the effects of time on its mechanical and electrical qualities must be taken into consideration. When I introduced the joint to the Society in May last I believed it would more than fulfil all the requirements asked for by Mr. Culley and others, but I could then only give the results of two months' experience. Now I can give results extending over a much longer period, and speak with greater confidence of both its electrical and mechanical qualities. Joints have been made in various sized insulated wires, and subjected to every conceivable test, with a view not only to their mechanical and electrical qualities, but also to their suitability in every respect for the purpose for which they are intended, and the results have been highly satisfactory. In a previous paper I recommended for making the joints the compound which has already been referred to in this paper, but, although that compound is all that could be desired for the purpose for which it was invented, it is not the most suitable for these joints, and I prefer to use one composed of resin and gutta-percha *only*. It has also been found that while joining the very small

wires—which, unfortunately, under a wrong notion of economy, have become the recognised size for wires to be laid in the ground in this country—the very thin covering of gutta-percha soon becomes softened by heat, and the slightest bend of the wire, while the gutta-percha is in that state, causes the thread at the end of the mould to penetrate to the conductor. To obviate that, in the moulds for the small wires the thread is not cut, but the aperture at each end of the mould is smooth, and larger in diameter than the wires to be joined. The compound in a plastic state is extended over the gutta-percha at each end of the joint a short distance beyond the length of the mould. Thus the insulating material is thickest at the joint. Joints thus made have been subjected to a pressure in water of 1,000 lbs. per square inch for long periods of time, and their insulation has remained intact.

In 1853, when each Telegraph Company was pushing rapidly through the country their underground system, some of the wires used contained 63lbs. of copper and 131lbs. of gutta-percha, and others 63 lbs. of copper and 103 lbs. of gutta-percha, per statute mile, their external diameters being $\cdot276$ and $\cdot247$ of an inch. The wire used at the present time for underground work is much smaller, and generally contains only 39lbs. of copper and 46lbs. of gutta-percha per mile, the external diameter being only $\cdot171$. Even with this small size the electrical requirements can be more than fulfilled, but it is not of sufficient strength to withstand the rough usage to which the wire is often subjected. For underground wires the weights per mile ought never to be less than 63lbs. of copper and 81lbs. of gutta-percha; the external diameter would then be $\cdot221$ of an inch. The wire should be supplied in the required lengths without any joints; each length should be evenly wound on a suitable reel and immersed in water, and kept at a uniform temperature of at least 24° C. for twenty-four hours before being tested. To obtain the resistance of the gutta-percha a battery of sufficient tension should be employed, so that with a sensitive mirror-galvanometer the deflections would be about one hundred divisions after one minute's electrification. Both positive and negative currents should be applied for several minutes, and the deflections at the end of each minute carefully noted. The

electrostatic capacity of each length and the resistance of the copper conductor should also be recorded, the capacity test being applied previous to that for insulation.

Various methods have been adopted with a view to the more effectual protection of the gutta-percha when laid. I have known gutta-percha covered with lead to answer remarkably well, but that has been only where the core has been of sufficient strength to withstand the strain applied if the lead be drawn over the core by the cold process, or where the gutta-percha has been of sufficient thickness to resist the heat when the lead has been applied by the hot process. It is very hazardous to cover the small cores usually used in this country with lead either by the cold or hot process. In the former case I have known the core to have been so stretched that the copper wire, in course of time, has knuckled up, and, penetrating the gutta-percha, has come into direct contact with the lead. In the latter case samples have come under my notice in which the heat has been sufficient to soften the gutta-percha and allow the copper wire to drop through it. Cores having good proportions of gutta-percha, and copper taped and drawn into iron pipes laid on the ground, answer well. I could instance a case where ten miles of wires so laid have now been in daily use for ten years, and during that time has never once required attention, and its electrical condition at the present time is all that can be desired.

Another plan would be that in which the insulated wires are twisted together in seven or any other convenient number, "served" with wet tanned tape or other suitable materials, and then surrounded by iron wires, the whole being covered with Clark's compound, or with the prepared canvas as supplied by Messrs. Johnson and Phillips—a miniature submarine cable in fact. I know of no data by which to form any idea of the lasting qualities of a cable of this description, more especially if laid in iron or earthenware pipes. Something similar to this has long been adopted on the continent with most satisfying results. This form of cable for long lengths may be objected to on the ground of induction, but let us not forget the same objection was brought against long submarine cables; but, once having got a long cable laid, means were soon

found to work it at a speed never before dreamt of. Might not similar results follow the completion of a good long subterranean line?

A cheaper, and certainly one less influenced by induction, might be constructed as follows:—A core containing not less than the proportions of gutta-percha and copper I have already stated might be served with two lappings of wet tanned tape, the second lapping to be wound the reverse way to the first, but both to be put on at one operation, the core to pass from one reel to another while being so covered, the reel containing each length of taped core immersed in water and kept there until required to be drawn into suitable large earthenware pipes already buried to receive it. The length of each section not to be greater than can be conveniently drawn into the pipes without applying a force sufficient to stretch the wire, enough slack to be allowed at each test-box for making the joint. With the proposed system of jointing a few feet would be sufficient to allow of a joint being re-made several times.

On the table before you are samples of core and cable such as I have referred to; also a variety of joints which have been made by way of experiment during the last seventeen months. No special care has been taken of them; they have been exposed to the action of both water and air. Each one, or set, has the date when made, and its present electrical resistance marked on it; and I think you will admit that the results are highly satisfactory. One objection which has been made against this system of joint is that it would occupy too much room. I have therefore placed before you one small test-box containing twenty joints, and another form of test-box, which I presume would not be too large to be used even in the streets of London, containing thirty joints, and would hold one hundred more if required.

In conclusion, if the use of such small wires and tar be abandoned, and the same amount of care is bestowed on wire for underground purposes as is usually adopted with that for submarine cables, and they are protected from injury when laid, there need be no fear in the future of the durability of underground wires.

The PRESIDENT: Before we proceed to the discussion the Acting-

Secretary will read a short paper on Underground Telegraphs in France which has been sent by Mr. Aylmer, the Society's Honorary Secretary in Paris.

UNDERGROUND TELEGRAPHS IN FRANCE.

By Mr. JOHN AYLMER, Local Honorary Secretary for France.

That the manufacture and laying of efficient underground telegraph wires is one of the questions seriously occupying the attention of telegraph engineers is sufficiently proved by the manner in which it has attracted the interest of this Society. Lengthy and most able papers, followed by searching discussions, have from time to time, and more especially quite lately, been read at its meetings. These have, however, and almost of a necessity, been confined to a description of what has been done in England in the construction of these lines; but, as no man can say that he has nothing to learn from his neighbour, I think it may help to elucidate this very important question and interest the members present if I bring before them some account of how the matter is being dealt with in France. I do not propose to compare the system there followed with any other, nor even to offer any opinions upon it, leaving it to each one to form his own conclusions as to its merits and defects; this paper is not critical, but will be confined to a concise technical description of the *faits accomplis*.

It may be interesting to commence by glancing very briefly at the earlier efforts made in France to lay down underground wire, though their chief value may only consist in the experience gained in learning the causes of failure.

The first attempts were merely by burying copper wires covered with india-rubber, the next by similarly treating gutta-percha-covered wires; of course both quickly failed, for such wires simply laid in the bottom of a trench could not last long. Towards 1852 the plan was tried of drawing insulated wire into a lead pipe of as near as possible its own diameter. This was a great step in advance, *but it did not answer*, by reason of the joints in the lead pipe

allowing infiltrations of street gas, which quickly destroyed the gutta-percha, besides which the latter frequently got so torn in the operation of being drawn into the pipe as to establish contact between the conductor and the outer lead-covering.

Some years later further experiments were made with the view of establishing a complete underground system in Paris. It had been observed that naked wire embedded in asphalt some ten years previously had retained its insulation, and a plan was devised for using this material in the protection of buried wires. A trench of about five feet deep was dug, and a layer of fine sand spread in it; iron wire of No. 8 B.W.G. was chosen, on account of its being less sensible than copper to the variation of temperature caused in it by reason of its contact with the hot asphalt; the wires were stretched in the trench in sets of 4, 6, or 10, and in sections of 90 yards long; they were held at an uniform distance of one inch from each other by means of specially constructed guides, which could be removed after the asphalt had been applied; a hot compound composed of 60 parts of asphalt, 7 of bitumen, and 33 of fine washed gravel was then poured in, the proximity of the guides preventing the wires from touching each other on account of the "sag" they would take from expansion of heat; the whole mass quickly solidified and the trench was filled in. The cost of these lines was about £40 per wire per mile, exclusive of the trench digging. Another similar line of ten miles length was soon afterwards laid down, and answered admirably for a few years; but ultimately loss of insulation and finally contacts became frequent; movements of the soil cracked the insulating compound, which moreover lost its qualities and became soft where exposed to the action of escapes from the gas-mains.

In 1858 another attempt was made with gutta-percha-covered wires, but, instead of being laid separately, each had, in addition to two coats of gutta-percha, a protection of tarred hemp, and five of them were twisted up into a cable, which was then wound round with tape and drawn in to a lead pipe. The whole was simply laid in a trench and worked well at first, but the want of an adequate protection against outward mechanical injury and movements of the surrounding earth, as well as the unreliableness of the joints in the lead pipe, soon caused its break-down and final abandonment.

I now come to the type of cable and mode of laying as fixed upon some 12 years ago, and which, with some slight modifications of detail, is that still employed.

It is here necessary to note that there are two different and distinct conditions under which street work is carried out in Paris and some other large towns in France. Firstly, there is the case in which the wires or cables are, properly speaking, buried underground, and secondly, that in which they are laid in the sewers.

As is pretty generally known, there is a very complete system of sewers in Paris, branches of which radiate under even very secondary streets; they are not what may be popularly termed large drains, but are veritable sub-ways, in the smallest of which a man can freely move about. The main ones are broad and lofty tunnels with foot-ways on either side, and the sewerage flowing at a lower level in the centre; they are kept scrupulously clean, and frequent man-holes, opening into the foot pavement above, give easy means of access and afford light and ventilation. The unusual advantages offered by these sewers are naturally utilised for laying in them, or rather fixing against their sides, water and gas mains, pneumatic tubes, and telegraph wires.

When more than one underground wire is required, the requisite number are always made up into cables, instead of being laid down as separate wires; these cables contain from two to seven cores. The following table shows the chief proportions and weights of the two cables that are the most generally employed, all others being only used for special circumstances. The cable B is applied on the longer and more important lines, whose overhead wire is No. 6 B.W.G.; cable C is used on less important or short circuits, whose air line is of No. 8 B.W.G.

Cable.	Diameter in inches.		Weight per mile.		No. of cores in cable.	Diameter of cable.		Weight of cable per mile.	
	Copper.	Core.	Copper.	Gutta-percha.		Taped.	Leaded.	Taped.	Leaded.
B	0.082	0.200	84 lbs.	59 lbs.	7	0.78 in.	0.88 in.	0.68 tons.	2.43 tons.
C	0.059	0.177	43 lbs.	50 lbs.	7	0.70 in.	0.80 in.	0.51 tons.	1.70 tons.

In both of these cables the conductor is composed of seven wires twisted into one strand, which then receives two layers of gutta-percha of the required thickness, separated from the copper and from each other by a coating of Chatterton's compound; a covering of tarred hemp thread is then wound round it, and seven of these cores are twisted up into a cable, which is protected with a serving of stout tarred hemp strand, and finally has an outer covering of strong tarred tape. Both the hemp and the tape are steeped in sulphate of copper solution before being tarred, and none but the best Stockholm tar is used. The cable thus composed is ready for laying underground; but in the case where it is destined to be hung in a sewer, instead of being entered, it receives still another cover of lead. The pipe into which the cable is drawn has an internal diameter as little as possible larger than the outer diameter of the cable, and is 0.05 of an inch thick. As long a length of this pipe as is practical is laid on an even floor, and a cord passed through it by means of a carrier blown through it by an air-pump; the cable (which is rubbed with talc to reduce friction) is then pulled, in and the whole is finally passed through a wooden die, which causes the lead to exactly adapt itself to the cable. Lengths of about 100 yards are thus prepared and are afterwards joined up before being laid.

When the cable is laid underground, that is to say, is buried in the earth, it is always protected by cast-iron pipes; the pipes vary in diameter from 2 to 4 inches, according as they are to contain from 2 to 6 cables; they have a useful length of 7 feet, and are 0.3 of an inch thick; one end is plain and the other has a socket, the same as ordinary water-pipes; each pipe of the larger kind weighs 3 qrs.; they are carefully cast so as to be as smooth as possible on the inside; they are tested with a water pressure of five atmospheres, and are coal-tarred. The trench is dug as far as possible at a depth of $3\frac{1}{2}$ feet, about 50 yards run of piping is laid in, and after the joints are made good by leading the section is proved by an air-pump, and must hold a pressure of two atmospheres for at least 10 minutes, without any loss being indicated by a gauge. Every such section is laid at 18 inches interval from its neighbour, and over one of the ends of two adjoining sections there is slipped a

piece of piping 3 feet long and of half-an-inch greater interior diameter than the external diameter of the pipe it covers; these are technically termed "muffs," and have a strengthening ring cast on near their orifices. When the section of piping is thus prepared the trench is filled in, except at the "muffs," which are left uncovered until the cable has been drawn in; after this has been done the "muffs" are slipped along so as to bridge the interval of 18 inches left between each section of pipes, and cover 9 inches of main pipe on either side; the joints of the "muff" are then made good with lead, and the filling-in of the trench is completed. In addition to a "muff" at every 50 yards in a straight line one is placed at either side of every angle; they are carefully numbered, and their position marked overground, and on a plan, so that they may be easily found. If any given section of the line has to be tested it is only requisite to dig down to the corresponding "muff," break its joints, slip it along the main pipe, and so expose the cable; after tests and any necessary repairs all is placed in position as before. In case there are any angles in the line of a radius for which iron piping cannot easily be procured, they are formed of the requisite length of lead pipe, which is secured over the ends of the main pipe by screw-up iron collars, which are protected from outer pressure or other injury by being embedded in masonry.

The cable is drawn into the pipe by lengths of about 200 yards where the line is straight; as each pipe is laid, the end of a light cord is passed through it so as to reach from end to end of a section of 200 yards; by its means a strong rope is drawn through, to one end of which is attached a guiding carriage; this consists merely of a bar of iron with a hook at one end to take the rope, and a sort of tail at the other, to which the cable is lashed; in its centre are three wheels, so pivoted that the surface of two of them is a perpendicular plane to that of the third. The reels containing the cables are conveniently placed, and guide-wheels interposed where necessary between them and the pipes; the ends of the cables are led under or over these wheels, as the case may be, and are attached to the guiding carriage, which is then drawn into and through the tube by a winch hauling on the other end of the rope. As the cable

is supplied from the manufactory in lengths of 400 yards, the other half of this length is in like manner drawn into the pipes lying on the other side of the "muff:" where operations were first commenced; thus there will only be joints in the cable at every 400 yards. In cases where, by reason of there only being a few cables to draw into a large-sized pipe, the friction opposed to the travelling of the cables is small, the whole 400-yard section is pulled in at one operation and in one direction. After the cables are in and the section has been tested, the "muffs" are all slipped into their places, their joints are made good, and the trench-filling is completed.

In sewer work the lead-sheathed cable, as before described, is simply hung against the side wall, and as high up as possible, so as to be out of the sewer-men's way; wrought-iron galvanised staples, formed of a piece of stout flat iron, bent at a right angle, are let into the wall at intervals of a yard, and to such a depth as that the space between them and the surface of the wall shall only be sufficient to allow a cable to pass; the cables are placed in them one by one, and over one another; the staples are of sufficient depth to hold five cables if necessary; any cable requiring repairs is easily lifted out by merely holding up those above it; in cases where only one single cable is fixed in a sewer it is held by common small round-headed galvanised staples merely hammered in. In these cables the joints in the lead sheathing have to be made so as to prevent the entrance of damp, and more especially gas infiltrations. The following plan is found very efficient: The core joints are made in the ordinary manner, and, being held in a bundle, are tightly wound round with a broad band of stout vulcanised india-rubber, which is tied round with strong yarn; tarred canvas is laid on over this, and is likewise tied; then a piece of lead piping about 2 feet long, which is slipped on to the cable before the joint is commenced (just as are the "muffs" on the iron tubes), is then brought over the joint, and its ends pinched tightly round the sound cable; the whole, and for a few inches on either side of the joint, is finally wrapped with tarred canvas, well bound with galvanised iron wire. The result is an excellent and very compact joint, formed without the intervention of heat, which (as was the

case with joints made with fusible alloys in some of the old cables) would be fatal to the gutta-percha. The electrical qualities stipulated for by the French Administration for all underground wires are that the copper shall have a conductivity of not less than 80 per cent. of pure copper, and that the insulation resistance of the dielectric shall not be less than 675 megohms per statute mile at 20° Centigrade, but better results than these are obtained in practice.

The following shows the maximum cost of establishing lines such as I have been describing. In order to present a fair average the estimate (based upon work actually done) is for one statute mile of four full-sized cables, each containing seven separate conductors, or twenty-eight wires in all, laid underground in iron pipes of three inches diameter :

Cost of 4 miles of cable of 7 conductors, £145 per mile	£580
Cost of iron pipes, muffs, lead, and other accessories	232
Digging and filling in trench, laying pipes, placing cables, and all other labour	238
	<hr/>
Total	£1,050
	<hr/>

Which equals £37 10s. per conductor per mile.

A statute mile of similar line laid in the sewers would cost—

Cost of 4 miles of cable of 7 conductors sheathed in lead at £183 per mile	£732
Iron staples, fixing, laying cables, and all other labour	72
	<hr/>
Total	£804
	<hr/>

Which equals £28 14s. 4d. per conductor per mile.

Within the city of Paris there are 119 miles of underground line at work, of which 39 miles are laid in buried iron pipes, and 80 miles are in lead-covered cables laid in the sewers—the total length of separate conductor in them is 2,561 miles. In the chief provincial towns in France there is about 100 miles of similar lines at work. Last year a line for parliamentary service was laid from

Paris to Versailles ; it is 12 miles long (of which about a third is sewer work), and has three cables of seven conductors each.

In conclusion I will say a few words as to the practical results obtained with lines constructed upon the principles I have described. The lines laid in pipes are found to be very reliable, there being no test-boxes or other openings on the surface ; the line being in fact hermetically sealed up on its whole length, is free from mischievous or ignorant interference ; carefully marking the positions of the " muffs " renders the finding of any given section of 50 yards a matter of ease and certainty. Repairs are easy, new cable being drawn in by the act of pulling out the faulty one. Notwithstanding the precautions taken with the joints in the iron pipes, water generally finds its way into them, but is not of any practical harm.

The sewer lines answer admirably ; repairs are most easily effected, the joints in the lead coating stand very well, the use of the vulcanised india-rubber binding immediately over the gutta-percha joints gives a first-rate result, it being put on stretched makes it grip well by reason of its elasticity, and upon opening out joints of several years' standing they are found as unaltered, and the gutta-percha of the cores as fresh, as when first made ; these lines are laid with the greatest celerity, miles of communication in any desired direction being established in a day.

Lines constructed upon these two systems have now been at work for over twelve years ; none of them have broken down, nor show signs of decay ; in the 2,561 miles of wire laid under the streets of Paris there are not more than one or two cases of interruption per year, and even these arise from some unlooked-for mechanical injury caused by workmen in the sewers.

The PRESIDENT : This paper of Mr. Aylmer's supplements in a very interesting manner the information given by Mr. Willoughby Smith. It is interesting to know how underground telegraphs have been dealt with in France, and it would be of additional interest and importance with reference to the discussion of this subject if we could receive some information of what has been done recently in Germany ; but I will now invite discussion gene-

rally upon the matters contained in the two papers we have heard read.

Mr. OTTO SCHRAMM : I can give a description of the construction of the underground cables lately adopted by the German Telegraph Administration, although I can afford no information with regard to the laying of the same. The cable consists of seven insulated conductors or cores, each composed of a strand of seven copper wires weighing 90 lbs. per nautical mile, insulated with two layers of gutta-percha and compound to a diameter of 5·2 mms.; the seven cores are stranded together, served with jute yarn, and sheathed with twenty-four best galvanised iron wires, each 2·6 mms. in diameter; the cable so far finished is then externally protected with a serving of tarred jute yarn and two coatings of asphalt compound.

Mr. TRUMAN : I rise to speak with great diffidence before a company so much better informed on these matters than I am, but there are one or two points in Mr. Willoughby Smith's paper on which I should like to ask a question. He lays great stress upon the injurious effects of tar. If tar is so very injurious, what is its effect in the compound of which he speaks? Mr. Willoughby Smith is aware that that compound is used largely in the manufacture of all submarine and underground cables, all cables being made in layers, the layers being joined together by this compound. I should like to know whether Mr. Willoughby Smith has found this material when in the compound which is now used so extensively in cables equally injurious. My own opinion is that it is quite unnecessary to join up the cables by means of that compound; I believe it will eventually be found that one of the best methods of manufacturing both underground and submarine cables will be to manufacture them of solid gutta-percha: that is, without layers, or, if in layers, without compound. I think the original use of compound was, and its present use is, simply to unite the layers of which the covering of the wire consists; these layers being considered requisite to insure centralization of the conductor, which was, and still is, one of the greatest difficulties experienced in the manufacture of gutta-percha-covered wire.

Then Mr. Willoughby Smith, in the beginning of his paper,

speaks about the state of the gutta-percha itself used in the early manufacture of underground wire.

Mr. Willoughby Smith knows that in 1860 very considerable improvements were made in the preparation of the gutta-percha; and he knows, also, that these improvements led very largely, not only to increase its utility electrically, but likewise to the increased durability of the gutta-percha; that is one of the reasons why I think the time has now come when it is no longer necessary to make cables in layers, because gutta-percha, as now prepared, is so much purer, and so much better understood, than it formerly was, that the necessity of building up the core, layer upon layer, no longer exists.

Again, with regard to Mr. Willoughby Smith's joint. Some time ago, when Mr. Culley introduced to this Society the subject of joints, I ventured to say that I believed a perfect joint is a thing which not only can be made, but has been made. I think the great defect we have been labouring under in the manufacture of the joint is, that we build up the joint as we build up the cable, layer upon layer, and unite these layers more or less by means of compound. I am sure that in the manufacture of a joint no compound should be used, and that, unless the gutta-percha covering the joint is absolutely continuous with the gutta-percha covering the rest of the wire, the joint will be weak, that is, if you take a thin slice from the cable crossing the joint, and, by applying microscopic, or other form of test, any want of union can be discovered, that joint will be imperfect. But it is possible to make absolute unions rapidly. Mr. Culley said sixty of the present joints could be made by one man in a day. I believe it is possible to make sixty joints in much less time than that, without any loss of continuity of the gutta-percha. I also think that it is possible to make the joint not bulky as Mr. Willoughby Smith's joint is, but of the same diameter as the wire if wished, and that, when made of that diameter and uniform, it will test equal with the wire, and remain as durable as the wire itself, it being made of the same gutta-percha as the wire. The way in which I make this joint is, by causing a stream of soft gutta-percha—hot—to pass over the joined copper wire, and over the exposed ends of the gutta-percha covering, through a mould. *The flow of hot gutta-percha through the mould*

and over the covered ends will wipe off the old surface of the gutta-percha, and leave the new, or rather, if I may be allowed to use the expression, leave a raw surface on the covered ends which unites absolutely with the raw surface of the new gutta-percha passing over it. This seems a difficult matter, but it is not so. I have joints so made which give admirable results, and they can be made by any ordinary workman, because he has nothing to do but make the copper joint in the usual way, and then, having the hot gutta-percha ready, and his proper tools, he causes it to flow into and through the mould, and the joint is made. There is no handling whatever required.

Next, as to the cost of underground telegraph wire, I believe it is capable of being considerably reduced; I mean the core itself. If a compound wire is used it involves a repetition of manufacturing cost for every layer. But in the manufacture of cables, both submarine and subterranean, I think the time has come when the present costly method of manufacturing in layers, and the everlasting doubt which exists whether this or that piece is perfect, may entirely be done away with. The core made at once in one piece, without layers, with perfect centralization, gives admirable results, and certainly at a much less cost than any other wire, as not a particle of gutta-percha is used that does not add its quota to the insulation.

I may, perhaps, be allowed to ask Mr. Willoughby Smith upon what he considers the durability of gutta-percha-covered wire to depend. I do not mean, as far as the mechanical matter of covering is concerned, but can he give us any information as to the properties of gutta-percha itself upon which its durability depends?

Mr. TREUENFELD: We have learnt from the valuable Inaugural Address of our distinguished President that the constancy of the dielectric of a cable chiefly depends upon the chemical action or chemical constancy of the materials of the dielectric. This is no doubt the case; and, bearing in mind that that is so, would it not perhaps lead to a solution of the question regarding the detrimental effect of the tar as an insulating material if Mr. Willoughby Smith would give us the chemical composition of the tars employed, and those especially which had this detrimental effect upon the dielectric? I think, by treating the question in a chemical way,

and investigating the oxydizing effect of the various tars employed, a solution could be arrived at, because it is very well known that the material of tar has a very wide area. I do not think that there are two tars of the same chemical composition; anyhow there are hundreds of varieties of tar, and, in order to come to a conclusion as to which are the detrimental ones, it is necessary to know what the chemical compositions of these various tars are.

Mr. W. H. PREECE: It is always interesting to watch the teachings of experience and the results of practical experiments. It may perhaps be interesting to some members of the Society to know the reasons why tar was introduced in the first instance as a protecting serving to gutta-percha and why it failed. When gutta-percha was first introduced in England as an insulating coating for wires, it was applied in a very crude state. It was, when not used under water, sometimes encased in lead pipes, and being usually exposed it was subject to that particular oxydizing action which led to its acquiring that dry, brittle, snuff-like form with which we are so well acquainted. In 1852, when Mr. Edwin Clark was the engineer of the Electric Telegraph Company, he studied with great care the action of various oxydizing agents on gutta-percha, and he arrived at the conclusion, now well established, that in the manufacture of gutta-percha a quantity of water became mechanically united with it, and when the gutta-percha came to be exposed to changes of temperature this water evaporated and left behind it a porous mass of resin. He thought if the wire were covered with any substance which would fill up the interstices of the percha left vacant by the water, with some insulating compound, probably the gum would retain its insulating property; consequently, he introduced a method of coating the gutta-percha with tape, the tape itself being saturated with tar. In carrying that into practice we suffered from inexperience, jointing was scarcely known, various blunders were committed, and the greatest blunder of all was that of drawing the gutta-percha in its state of covering through a bath of hot tar and then exposing it to the sun upon wooden bars. The result was, the copper-wire lost its centering, and came to the surface, and the wire so served very speedily lost its insulating properties. The consequence was, the wires which had been so dealt

with very soon became useless, and underground wires fell out of favour. Eight wires were laid in 1853 between London, Manchester, and Liverpool, and it was with great difficulty they were kept in working order, I think, for ten years, but at the end of that time they were removed and superseded by overground lines.

Our experience in England in the use of gutta-percha for underground purposes is pretty extensive. At the present moment in the Post-office we are working 400 miles of underground pipes and probably about 5,000 or 6,000 miles of underground wires. All these wires were more or less served with tape and served with tar, and I am bound to confess, that though the first wires failed, as I have explained, and though Mr. Willoughby Smith has narrated to us experiments detailing the failure of tar-covered wires, yet I am by no means satisfied that the result is due to the tar itself. In early days we used coal-tar, and no doubt coal-tar is to a certain extent a solvent of gutta-percha, but Stockholm tar is not; and, as Mr. Treuenfeld suggests, it would be interesting to know what chemical reaction there is between Stockholm tar and gutta-percha.

The practical lesson to be drawn from Mr. Willoughby Smith's paper is, not so much that tar is so injurious to gutta-percha as that a better method should be adopted for making joints. My own experience is we do not suffer so much from the absolute destruction of the gutta-percha as from the failure of the joints. Our experience of underground wires is not long enough: that is, the progress of telegraphy, the increase of business, the alterations, the transferences, the formation of companies and their abolition, their purchase by the Government, &c. have not kept us intimate with any line of underground pipes sufficiently long to enable us to judge accurately of what the action of gutta-percha in underground wires is. The only line I can recall to mind is one which was laid down in Brighton from the chief station there to the racecourse, a distance of a little over two miles. Pipes were laid in the dry chalky ground, where moisture was very rare, and three or four gutta-percha-covered wires were laid in them, and those wires remained in working order for twenty-one years. The pipes were *laid in 1853 and the wires were taken up in 1874.* It is true when

these wires were withdrawn they were decayed, and they were of that dry, brittle character to which I alluded just now. That is the only case within my own experience where we have a definite idea of the absolute life of gutta-percha in underground lines, though there are several lengths in the streets of London and in other parts of the country where the life of gutta-percha is equally long. I think in experiences of that kind, if gutta-percha, made under the difficulties alluded to in 1853, has succeeded in maintaining itself intact for over twenty years, we may hope, with the progress made in the present day and with the experience the gutta-percha manufacturers have acquired, that at any rate the lines of the future, if they are not subject to the same detrimental influences as at Brighton, may at least be expected to exist for more than twenty years.

The improvements that have been made are very numerous, and certainly in nothing more than in the methods of testing. Mr. Willoughby Smith mentioned that in early days they were contented to use a rough galvanometer and pricked the wires. That was the first process, and was the authorised system of testing. We know better now, and telegraph engineers, or persons in charge of underground lines, who prick a wire to test its condition would, I think, be speedily sent about their business.

Again, in the quality of copper we have gained enormously. In early days we used No. 10 B. W. gauge; now we have better wire of less gauge—No. 18. There is the same improvement in the quality of iron as has been effected in that of copper; and, thanks to the power which testing gives us, a revolution has been produced in the quality of iron for overground lines, as has been the case in copper for underground. I remember the time when underground wires gave a resistance of from 30 to 40 ohms; we now get them with a resistance of only about 22 ohms. The No. 8-gauge iron wire, which used to give a resistance of 15, 16, and 17 ohms, now gives only 12 or 13.

The chief point, however, to aim at is cheapness. Our worthy President in his Inaugural Address pointed to the hope that other materials besides gutta-percha will be introduced, which will tend, if not to reduce the cost of gutta-percha, or improve its manufacture,

to introduce some material which will bring the cost of underground wires within our means. The reason why underground wires have not been more extensively used is, not the want of efficiency or durability, but their excessive cost. We have heard that in Paris the underground wires cost £37 per wire, per mile, in pipes, and in sewers as much as £28 per mile. What it is in England I do not remember, but I think it cannot be much less than that. The future of underground wires does not, in my opinion, depend so much upon the manufacture or quality of gutta-percha, or any new materials, as upon the introduction of some method which will reduce the present exceeding cost.

Sir CHARLES BRIGHT: I was not here early enough to hear the whole of the paper. My experience of underground wires is principally derived from works carried out a long time ago, and, with the exception of some short lines connecting the ends of submarine cables in foreign countries, I have not laid any underground wires for many years. I superintended the construction of a considerable length of underground line in this country at the time when the Magnetic Telegraph Company commenced its system, and the whole of those wires were made by the Company with which the author of the paper has been so worthily connected for so many years. I may be travelling over ground which Mr. Willoughby Smith has gone through in his paper, but I will give a short history of those lines: We commenced laying wires from London to Manchester and Liverpool, from there to Preston, and thence to Carlisle; from there to Dumfries and Glasgow and to Portpatrick, where the cable was laid across the Irish Channel to Donaghadee; from there to Belfast, and thence down the road through Dundalk and Drogheda to Dublin. There was a line of 10 wires from Manchester to Liverpool, and various numbers of wires which I cannot remember in the other lines. In the streets of towns the wires were laid in iron pipes, and along the country roads in troughs of timber, covered by a wooden lid in some cases, and by a lid of galvanised iron in others. The troughs were creosoted, and the depth of the trench was nowhere less than two feet. In the greater part of these lines the wires were made into a cable and served with tarred yarn. In a small portion of the line the gutta-

percha-covered wires were laid naked in the troughs. Our experience was shortly this: in the course of seven or eight years we found the wires became defective from a number of causes, and eventually they were all replaced, except in the streets of towns, by overground lines of iron wire erected in the usual manner on the highway. The causes of defects were numerous. In the first place, at the time the wires were laid, now 23 years ago, there were inherent defects in the manufacture of the gutta-percha, which contained a quantity of woody fibre and various other impurities. With respect to the tar to which Mr. Truman has alluded, we had no layers of tar at all between any of the separate coverings of any of the wires laid in 1852, 1853, 1854, and I think the first application of the compound (containing tar in addition to the other ingredients) between layers of gutta-percha-covered wires was made in 1858 or 1859. I think it was first applied to the wires of the Electric Telegraph Company's line to Holland and afterwards to the line to Heligoland and Toning; so that the tar as an intermediate coating did not apply to the wires which were defective in the case to which I have alluded. The joints were frequently found defective when we repaired the line; some of these were joints made in the factory, and some of them were joints made during the construction of the lines. Another cause of defect was the gutta-percha being in some places alternately wet and dry, which was frequently the case, especially on rising ground, where the troughs underground would be sometimes full of water, and sometimes dry. When the wires in such situations were examined it was found that the gutta-percha was cracked vertically in many places, and there were sometimes as many as a dozen small cracks in the length of an inch. Another cause of defect was the roots of trees, which produced a fungoid growth upon the wires, causing rapid decay of the gutta-percha. For my own part I have never been able to trace any decay to tar,—in fact, as I have said, we had no tar in the joints or between the layers, and those wires which were made up into a rope and covered with tarred hemp lasted longer than those which were laid naked in the troughs or pipes; but that arose probably from the air being more excluded.

The PRESIDENT: Before calling upon Mr. Willoughby Smith to reply, I will say a few words with reference to one question raised, which is somewhat of a chemical question: that is, with reference to the character of the tar used as a saving for gutta-percha-covered wires. Mr. Treuenfeld pointed out that there are different varieties of tar, more especially of coal-tar; but that is also the case with Stockholm tar. Tar is a simple chemical substance; but it is, generally speaking, a mixture of substances possessing more or less solvent action upon bodies of the character of gutta-percha, and it depends upon how far, in the preparation of the tar, the substances which act more especially as solvents have been separated from that which is the tar proper, produced by the distillation of the wood, whether the latter is more or less solvent or softening in its action when applied to gutta-percha. I apprehend the action of Stockholm tar, when found to be detrimental to the somewhat porous gutta-percha coating of insulated wire, is due to those proportions of the tar which exert a solvent action upon the material, and which after a time evaporate and leave the gutta-percha more porous than before. On a former occasion I pointed out that, even with the present improved methods of manufacturing gutta-percha, it varies very greatly with regard to the amount of water which is retained in it, and this water will evaporate in time and leave the gutta-percha more or less porous in character, and more or less directly susceptible to the penetrating action of the solvents which may be contained in the tar; hence the action, even of Stockholm tar, may have a deteriorating effect upon the gutta-percha.

Mr. WILLOUGHBY SMITH: With regard to the wires laid in Germany at the time I speak of (1852-3), I do not think any protection was adopted, for, with a view to protect the gutta-percha from the ravages of rats and other vermin, a large percentage of sulphur was mixed with the gutta-percha before covering the wire with the same. Messrs. Felten and Guilleaume, of Cologne, have been very successful with the wires they have laid in Germany. The specimens of their wires which I have seen resemble a multiple submarine cable, and I believe great care is taken both in the manufacture and laying of their lines. Hitherto the lengths *they have laid* have been comparatively short, but they are now

engaged in laying much longer lengths on the same principle, the core for the same being supplied by the Gutta-percha Company.

With regard to Mr. Treuenfeld's remarks relative to the chemical compositions of the various descriptions of tar, I have not made any experiments in that direction. Although tar injures the insulating properties of the gutta-percha, my principal objection to the use of it is, that its insulating properties conceal for a time any mechanical injury which the gutta-percha may have received.

I am pleased to hear Mr. Preece speak of a line which has been at work at Brighton for twenty-one years. I believe the fault has been in trying to take too much care of the gutta-percha. Protection from external injury when laid is all that is required. When in 1851 the four-wire iron-bound cable was laid between Dover and Sandgate, it was found to be one mile too short to reach the French shore. Four wires covered with gutta-percha, of the same size as those in the cable, were merely twisted together, and without any protection served as the shore-end of that cable for one month, and on the completion of the cable were used as part of the land-wires from Sandgate to Calais, buried in the sand without any protection, and I believe at the present time these wires are still doing good service in connection with underground wires. Mr. Preece says that the system of pricking was adopted in the Atlantic Cable of 1858. I never saw any pricking, but can readily believe it. Mr. Preece has also remarked on the question of cost; although in Germany they are laying more expensive lines than are now generally adopted in England, I believe, in the long run, their system will prove to be the more economical of the two.

It would be interesting to know whether the Government would be willing to pay for the use of a good underground line of wires, say from London to Manchester.

Sir Charles Bright is right in saying the compound was first tried in two of the four wires of the Zandvoort Cable.

Mention has been made of the use of tar in the compound. The compound to which I referred contains gutta-percha, Stockholm tar, and resin, but, in mixing the ingredients, the sting, if I may so call it, is taken out of the tar, and it has no effect on the gutta-percha when on the wires. That this is the case is clearly proved

by the fact that the compound has now been in use for twenty years, and never once during that time has been found to act otherwise than beneficially.

With a suitable protection and a sure knowledge that the insulation entirely depends on the gutta-percha, there need be no despair of the durability of underground wires.

The PRESIDENT: I am quite sure I shall only be anticipating the feeling of the meeting in returning their thanks to Mr. Willoughby Smith for the valuable information he has brought before us in his paper. We feel deeply indebted to him for this paper, and not to him only, but also to Mr. Aylmer for his interesting communication relative to the underground telegraphs of Paris. Papers of this character are most valuable to the Society, inasmuch as they often lead to the discussion of points which do not appear in the first instance to bear upon the subject, but which discussion elicits valuable information from those who have had practical experience in such matters.

The vote of thanks was unanimously accorded, and the meeting adjourned.

The Fifty-seventh Ordinary General Meeting was held on Wednesday, the 11th day of April, 1877, PROFESSOR ABEL, F.R.S., President, in the Chair.

The following papers were read by the Acting Secretary :—

QUADRUPLEX TELEGRAPHY,

by G. B. PRESCOTT, Western Union Telegraph Company.

The earliest published suggestion of the possibility of transmitting two communications in each direction simultaneously over the same wire was made by Dr. Stark, of Vienna, in 1855. At almost the same moment an independent inventor, Dr. J. Bosscha, Junior, of Leyden, who was engaged upon the same problem, read a paper before the Royal Academy of Holland, describing in detail the method by which he proposed to accomplish this result. He was followed, in 1863, by Marou of Berlin, who proposed a modification of Bosscha's system ; but it does not appear that either of these were ever introduced into practical use, and for many years very little attention seems to have been paid to the subject.

The revival of the system of simultaneous double transmission in America, and its extensive introduction into practical use both in this country and in Europe, resulting from the improvements of Stearn's,—notably his method of compensating the effects of the static discharge from the line by the application of the condenser, which was made known in the winter of 1871-2,—once more turned the attention of electricians to the problem of simultaneous transmission in the same direction.

In a paper published in June 1873, Oliver Heaviside, of Newcastle-on-Tyne, England, pointed out, as Stark and Bosscha had done before him, that the invention of a system of simultaneous transmission in the same direction furnished at the same time the solution of the problem of quadruple transmission. He says, "It is theoretically possible to send any number of messages whatever

simultaneously in one and the same direction upon a single wire. Now, by combination with a null duplex system, it becomes possible obviously to send any number of messages in the other direction while the opposite correspondences are going on, and without interference. Thus the working capacities of telegraphic circuits may be increased indefinitely by suitable arrangements."

During the summer of 1874, T. H. Edison, of New Jersey, while engaged at New York, in conjunction with George B. Prescott, Electrician of the Western Union Telegraph Company, in experimenting upon Stearn's duplex apparatus, with a view of introducing certain modifications and improvements therein, devised a system of simultaneous transmission in the same direction which differed materially in principle from any of its predecessors, and which was destined to furnish the basis of the first practical solution of the curious and interesting problem of quadruplex telegraphy.

The distinguishing principle of this method consists in combining together two distinct and unlike methods of single transmission, in such a manner that they may be carried on independently upon the same wire and at the same time, without interfering with each other. One of these methods of single transmission is known as the double-current system, and the other is the single-current, or open-circuit system. In the double-current system the battery remains constantly in connection with the line at the sending station, its polarity being completely reversed at the beginning and at the end of every signal without breaking the circuit. The receiving relay is provided with a polarised or permanently magnetic armature, but has no adjusting spring, and its action depends solely upon the reversals of polarity upon the line, without reference to the strength of the current. In the single-current system, on the other hand, the transmission is effected by closing and breaking, or increasing and decreasing, the current, while the relay has a neutral or soft-iron armature, provided with a retracting spring. In this system the action depends solely upon the strength of the current, its polarity being altogether a matter of indifference.

It will therefore be apparent that by making use of these two distinct qualities of the current, viz., polarity and strength, two

sets of instruments may be operated at the same time on the same wire. This method possesses, moreover, the important practical advantage that the action of each of the two receiving relays is perfectly independent. Each receiving operator controls his own relay, and can adjust it to suit himself without interfering with the other; a peculiarity that none of the former methods possessed. As soon as this method was practically worked out, it became at once obvious that any of the different methods of simultaneous transmission in opposite directions already in use might be applied to it, as Stark, Bosscha, and others had long ago pointed out, the result of which would be a practical system of quadruplex transmission. This was shortly afterwards done upon the lines of the Western Union Telegraph Company between New York and Boston, a distance of 240 miles, and both the bridge and the differential system of duplex working were tried in combination with it with excellent results. When, however, the apparatus was experimentally tested on a circuit of about 450 miles, the effects of static induction became very strongly marked, and it was found that these could be more conveniently compensated in the bridge than in the differential system. The former was therefore adopted for general use, as being better suited to the usually existing conditions than the latter.

Figure 1 shows the quadruplex apparatus as arranged upon the bridge plan.

T_1 is a double current transmitter or pole-changer, operated by an electro-magnet, local battery e_1 and finger-key K_1 . The office of the transmitter T_1 is simply to interchange the poles of the main battery E_1 with respect to the line and ground-wires whenever the key K_1 is depressed; or, in other words, to reverse the polarity of the current upon the line by reversing the poles of battery E_1 . By the use of properly arranged spring contacts, $s_1 s_2$, this is done without at any time interrupting the circuit. Thus the movements of the transmitter T_1 cannot alter the strength of the current sent out to line, but only its polarity or direction. The second transmitter T_2 is operated by a local circuit, and key K_2 in the same manner. It is connected with the battery-wire 12 of the transmitter T_1 in such a way that when the key K_2 is depressed, the

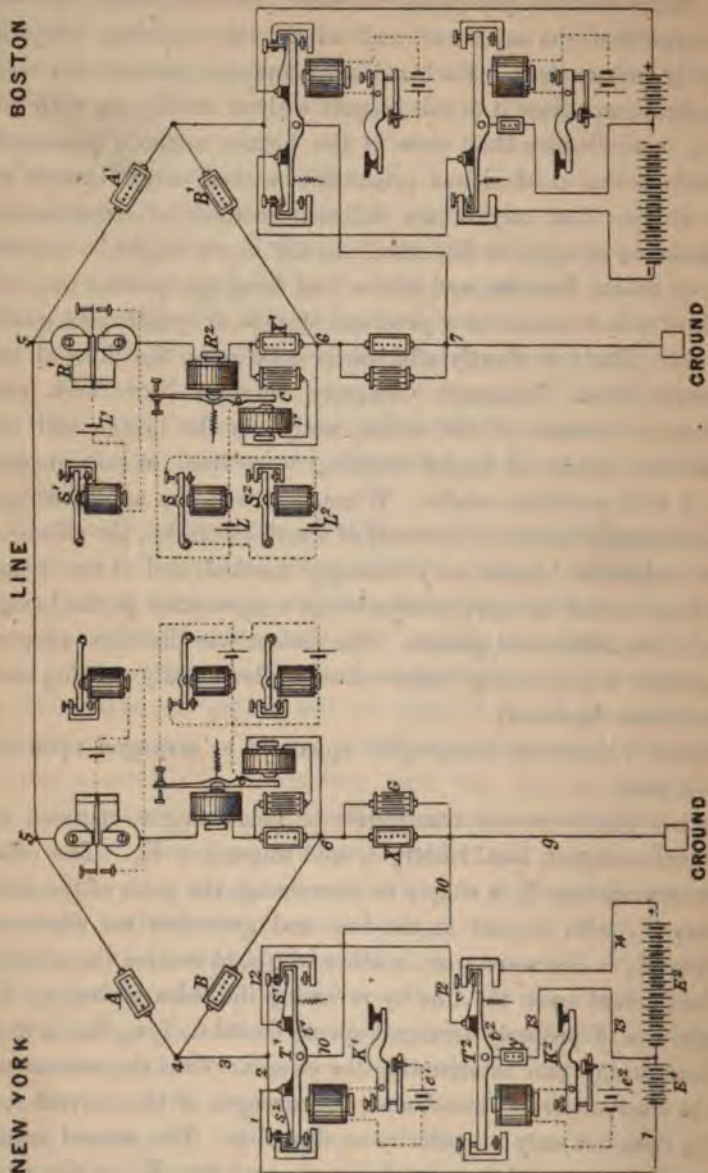

Fig. 1.

battery E_1 is enlarged by the addition of a second battery E_2 of two to three times the number of cells, by means of which it is enabled to send a current to the line of three or four times the original strength, but the polarity of the current with respect to the line of course still remains, as before, under control of the first transmitter T_1 .

At the other end of the line are the two receiving instruments R_1 and R_2 . R_1 is a polarised relay with a permanently magnetic armature, which is deflected in one direction by positive, and in the other by negative, currents, without reference to their strength. This relay, consequently, responds solely to the movements of key K_1 , and operates the sounder S_1 by a local circuit from battery L , in the usual manner. Relay R_2 is placed in the same main circuit, and is provided with a neutral or soft iron armature, and responds with equal readiness to currents of either polarity, provided they are strong enough to induce sufficient magnetism in its cores to overcome the tension of the opposing armature spring. The latter, however, is so adjusted that its retractile force exceeds the magnetic attraction induced by the current of the battery E_1 , but is easily overpowered by that of the current from E_1 and E_2 combined, which is three or four times as great. Therefore, the relay R_2 responds only to the movements of K_2 and transmitter T_2 .

The same difficulty which troubled former inventors arises again in this connection.

When the polarity of the current upon the line is reversed during the time in which the armature of R_2 is attracted to its poles, the armature will fall off for an instant, owing to the cessation of all attractive force at the time when the change of polarity is actually taking place, and this would confuse the signals by false breaks if the sounder were connected in the ordinary way. By the arrangement shown in the figure the armature of the relay R_2 makes contact on its back stop, and a second local battery, L_2 , operates the receiving sounder S_2 . Thus it will be understood that, when relay R_2 attracts its armature, the local circuit of sounder S_2 will be closed by the back contact of local relay S , but if the armature of R_2 falls off it must reach its back contact, and remain there long enough to

complete the circuit through the local relay S , and operate it before the sounder S_2 will be affected. But the interval of no magnetism in the relay R_2 , at the change of polarity, is too brief to permit its armature to remain on its back contact long enough to affect the local relay S , and through the agency of this ingenious device the signals from K_2 are properly responded to by the movements of sounder S_2 .

By placing the two receiving instruments R_1 and R_2 in the bridge wire of a Wheatstone balance, and duplicating the entire apparatus at each end of the line, the currents transmitted from either station do not affect the receiving instruments at that station. Thus, in fig. 1 the keys K_1 and K_2 are supposed to be at New York, and their movements are responded to only by the receiving relays R_1 and R_2 at Boston. The duplicate parts which are not lettered operate in precisely the same manner, but in the opposite direction with respect to the line.

In applying this system of quadruplex transmission upon lines of considerable length, it was found that the interval of no magnetism in the receiving relay R_1 (which, as above stated, takes place at every reversal in the polarity of the line current) was greatly lengthened by the action of the static discharge from the line, so that the employment of the local relay S^1 was not sufficient to overcome the difficulties arising therefrom. A rheostat or resistance, X^1 , was therefore placed in the bridge wire with the receiving instruments R^1 and R^2 , and shunted with a condenser C_1 of considerable capacity. Between the lower plate of the condenser and the junction of the bridge and earth-wire an additional electro-magnet r was placed, acting upon the armature lever of the relay R^2 , and in the same sense. The effect of this arrangement is, that when the current of one polarity ceases the condenser c immediately discharges through the magnet r , which acts upon the armature lever of relay R^2 , and retains it in position for a brief time before the current of the opposite polarity arrives, and thus serves to bridge over the interval of no magnetism between the currents of opposite polarity.

It will be seen that the combination of transmitted currents in

this method differs materially from any of those used in previous inventions. They are as follows:—

1. When the first key is closed and the second open — 1
2. When the second key is closed and the first open + 3 or + 4
3. When both keys are closed . . . — 3 or — 4
4. When both keys are open . . . + 1

Here we discover another very important practical advantage in the system under consideration, which is due to the fact that the difference or working margin between the strengths of current required to produce signals upon the polarised relay and upon the neutral relay respectively may be increased to any extent which circumstances render desirable. Within certain limits the greater this difference the better the practical results, for the reason that the range of adjustment of the neutral relay increases directly in proportion to the margin.

The ratio of the respective currents has been gradually increased from 1 to 2 to as high as 1 to 4, with a corresponding improvement in the practical operation of the apparatus.

From what has been said, therefore, it will be seen, that, before it became possible to produce a quadruplex apparatus capable of being worked at a commercial rate of speed upon long lines, it was essential that its component parts should have arrived at a certain stage of development. When, in the early part of 1872, simultaneous transmission in opposite directions was for the first time rendered practicable upon long lines by the combination therewith of the condenser, the first step was accomplished. It now only remained to invent an equally successful method of simultaneous transmission in the same direction, which, as we have seen, was done in 1874. The application of one or more of the existing duplex combinations to the new invention, to form a quadruplex apparatus, soon followed as a matter of course.

The quadruplex method which has been adopted as a standard by the Western Union Telegraph Company is based upon that shown in fig. 1, but embodies several important modifications and improvements, which have been made by Messrs. George B. Prescott and Gerritt Smith. By these improvements the working capacity

and general efficiency of the apparatus have been greatly improved since its first introduction into practical use. Fig. 2 is a diagram illustrating the method now in use. It will be seen that no changes whatever have been made in the principle of the transmitting portion of the apparatus, or the combination of currents sent to line in the different position of the keys, but portions of the receiving apparatus have undergone material alteration.

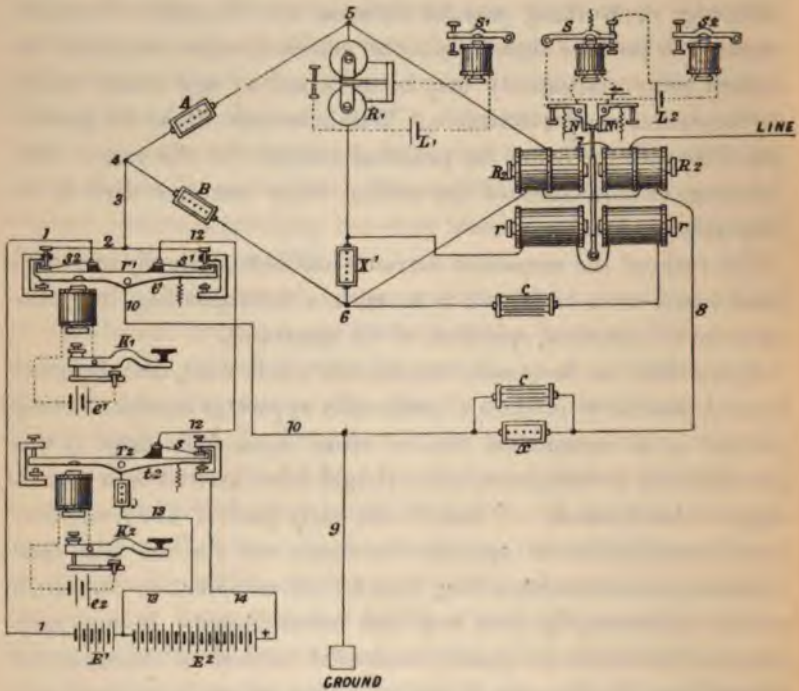

Fig. 2.

The polarised relay R_1 and its accompanying sounder are placed in the bridge-wire 5, 6, as before. The neutral relay, which was formerly placed in the bridge-wire, also has been discarded altogether, and replaced by a compound differential polarised relay R_2 . This is inserted, not in the bridge-wire, but in the line and earth wires, these respectively form the third and fourth sides of the

bridge of which *A* and *B* are the first and second sides. Thus, when the resistances *A* and *B* are made equal, the outgoing currents will divide equally between the line and the earth, and will neutralise each other in their effect upon the relay *R*₂. The latter consists of two electro-magnets facing each other, with a polarised armature between them. When no current is passing, the polarised armature is held in a central position between two spring contact levers, *N* *N*₁, and the circuit of the local relay *S* is completed through these and the armature lever. The springs of the contact levers *N* *N*₁ are adjusted with sufficient tension to prevent them from responding to the current of the small battery *E*¹ at the sending station, but the additional current from battery *E*² will overcome the spring of *N* or of *N*₁ according to its polarity, and thus break the circuit of the local relay *S*, which, by its back contact, will operate the sounder *S*₂. The electro-magnets *r* *r* are arranged to act in conjunction with *R*₂ *R*₃ upon the same armature lever, and are connected with a condenser *c* and a rheostat *X*¹ in the bridge-wire.

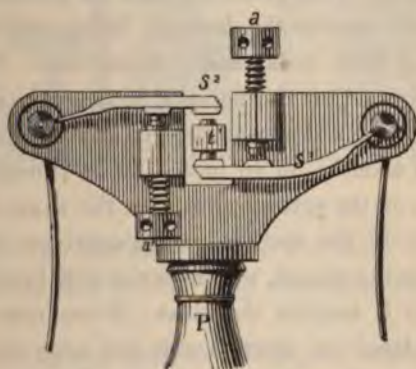

Fig. 3.

The double current transmitter is represented at *T*¹ in fig. 2, and is operated by the Key *K*₁ and a local battery *e*₁, usually of three cells. The most simple and by far the best double-current transmitter is constructed as shown in fig. 3. The drawing is an end view of the transmitter and shows the pole-changing apparatus distinctly. The adjustable contact screws *a* and *a*¹ are supported

by, and are in electrical connection with, the post P, which is in turn connected with the line-wire. The post also supports two contact springs s^1 and s^2 , which are insulated from it and connected by wires 1 and 12 with the zinc and copper poles of the main battery respectively. The lever t^1 of the transmitter is connected with the earth.

The proper adjustment of this transmitter is a matter of the greatest importance to insure the successful working of the apparatus. In order that it may follow the movements of the key with promptness, the play of the lever t_1 between its limiting-stops near the electro-magnet should not exceed $\frac{1}{32}$ of an inch. The contact screws must be so adjusted that at a point about midway of the stroke of the lever t_1 the springs s^1 and s^2 will both be in contact with it at the same time, but for the shortest possible period. The easiest way is to first temporarily adjust the upper limiting-stop at the opposite end of the transmitter lever t_1 so as to reduce the play of the lever to $\frac{1}{8}$ of an inch, or about half the ordinary distance allowed for a sounder. Then gradually raise the contact screw a^1 until the spring s^2 barely touches the lever t_1 , being careful to raise the screw no further than is necessary to do this. Then lower the contact screw a and adjust the spring s^1 in the same way. Finally, raise the limiting-stop at the other end of the lever, so as to give it the usual play of about $\frac{1}{32}$ of an inch. In its vibration the lever t_1 should touch one of the springs s^1 or s^2 at the same instant that it leaves the other. If the springs are adjusted too far apart there will be a break in the circuit, as the lever will break contact with one spring before it touches the other; if too near together, the battery will be placed on short circuit too long, from one contact being made before the other is broken. By careful adjustment this period can be reduced to almost nothing; and the more accurate this adjustment the better will be the performance of the apparatus.

The single-current transmitter is similar to the transmitter of the Stearn's duplex. The play of the lever of the transmitter should be about $\frac{1}{32}$ of an inch between the limiting-stops and the contact screw A, fig. 4, adjusted so that, when the key is closed and the

transmitter in the position represented, the spring B will be slightly separated from the contact point on the end of the lever D.

The compound polarised relay represented by R_1 in fig. 2, and the sounder connected with it, respond to the signals given by the double-current transmitter at the sending station. The relay consists of four separate electro-magnets, arranged in pairs, with their poles facing each other, upon opposite sides of a double polarised armature. The connections and principle of operation have already been explained in connection with fig. 2. The proper adjustment

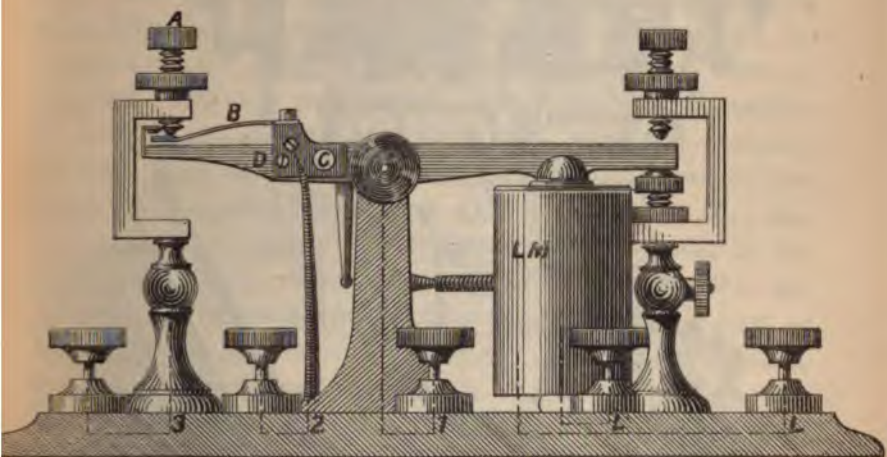

Fig. 4.

of the armature and local contact levers of this relay is a matter of much importance, and the following directions should be carefully observed.

Fig. 5 is a full-sized outline drawing of a portion of the compound relay, showing the contact levers and their adjustment. The two pairs of electro-magnets should first be adjusted by means of the check-nuts at the back, so that their poles are at equal distances from the opposite faces of the polarised armature. The play of the armature lever is regulated by the stops p^1 and p^2 , which limit the movements of the contact levers $N N$ in one direction, while the stops p and p limit them in the other direction. To adjust these levers the screws p^1 and p^2 should be withdrawn until the con-

tact points upon the armature level are touched by those upon each side upon the levers $N N$, so that the local circuit can pass through the lever from N to N when the armature is in a middle position,

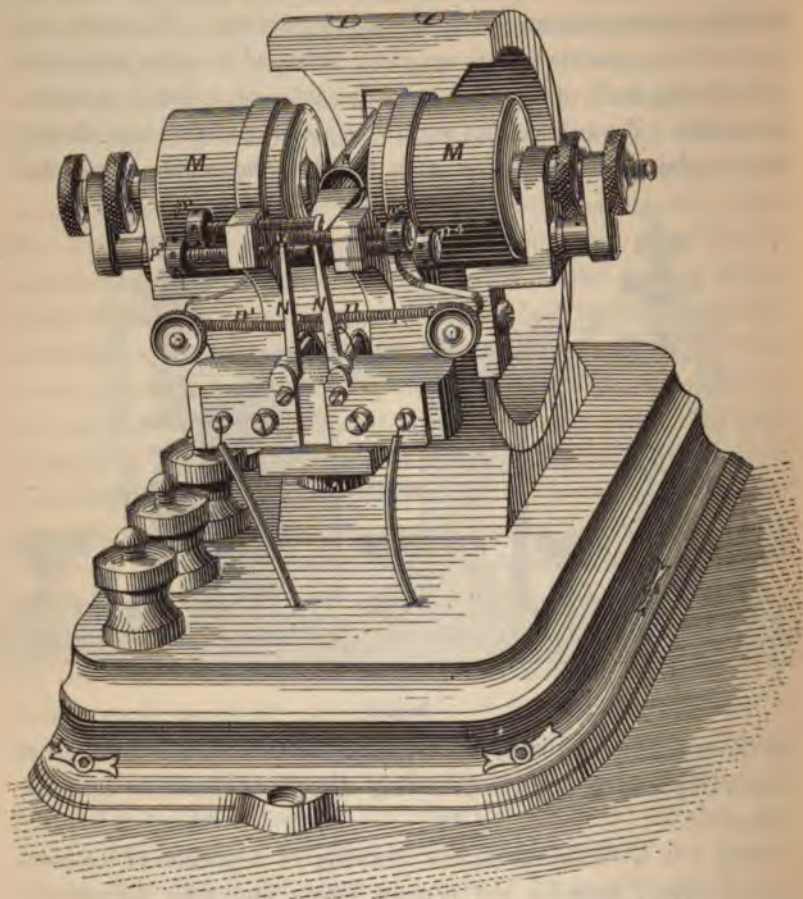

Fig. 5.

but will be interrupted by its slightest movement in either direction. The play allowed to the contact levers by the stops p^1 and p^2 may be, with advantage, considerably less than that of an ordinary relay. The proper tension of the springs u and u^1 depends upon the condition of the line current, and will be referred to hereafter.

The single polarised relay is shown at R_1 in fig. 2, and is simply a Siemens' polarised relay, which should be adjusted with a play about the same as that of the ordinary Morse relay.

The above arrangements having been properly made at both stations, the adjustment of the apparatus for working is effected in the following manner: One station, which for convenience we will call station A, commences by sending signals from the pole changing transmitter T_1 having been careful to leave key K_2 of transmitter T^2 open. Station B then signals to station A in the same manner, which signals will be received upon the polarised relay R^1 . If the signals come reversed, or on the back stroke, the direction of the incoming current through the relay must be reversed. Station A next instructs B to "ground." B complies by turning the arm of his switch, which sends the incoming current direct to the earth through a resistance which has already been adjusted to equal that of the entire battery ($E_1 + E_2$). Station A then "grounds," by placing his own switch in the same position, and adjusts his polarised relay R_1 , so that the armature will remain at rest indifferently upon either its front or back contact stop, when so placed by the finger. Next, station A closes the single-current transmitter T_2 by means of K_2 , and turns the switch back to its original position, that is, to the left, sending the entire battery to line. The resistance X should now be altered until the armature of the polarised relay R_1 remains indifferently on either side when placed by the finger as before. When this is accomplished the line resistance and rheostat resistance in X will be equal.

To obtain the electrostatic balance, station A transmits dots or dashes by means of transmitter T_1 , and at the same time alters the capacity of the condenser C, until it neutralises the discharge which takes place at the end of each signal, and is manifested upon the relay R_1 . The electrostatic balance of this relay insures that of relay R_2 without further precaution. Finally, station A again turns his switch to the right, and station B now proceeds to obtain a balance in the same way. Having accomplished this, he notifies A. Station B is then requested to send from transmitter T^1 , leaving T_2 open or at rest. The signals are

received at A on relay R_1 , and at the same time the springs $u u$ (fig. 5) of the compound relay R_2 should be pulled up sufficiently to hold the armature at rest in a central position, with the local relay or repeating sounder S closed. Next, B is requested to leave transmitter T_1 at rest, and sends signals on T_2 . These signals should be received at A upon the compound relay R_2 only. With currents of one polarity the armature will move to the left, and with currents of the other polarity to the right; but in either case it should operate the sounder S_2 by means of the local relay S.

When the armature passes from one extreme position to the other by a change of polarity upon the line, the relay should not give a false signal as it passes the central position.

The contact point of the local relay or repeating sounder S should be adjusted as close as those of an ordinary relay.

The above-described apparatus is suitable for use upon lines from 300 to 600 miles in length. For lines under 300 miles in length a modification of the standard apparatus of somewhat simpler construction is usually employed.

The principle of this apparatus will be understood by reference to the diagram fig. 6.

Both receiving relays R_1 and R_2 are provided with differential helices and polarised armatures, and in general the differential method is employed in place of the bridge. The relays R_1 and R_2 may be constructed as shown in the figure, or according to Siemens's pattern, as preferred. The combination of the outgoing currents differs from that employed in the standard quadruplex, and is as follows:—

K_1 open and K_2 open, current traversing line	- -	+ 4 B
K_1 open and K_2 closed	„ „ „	- - + B
K_1 closed and K_2 open	„ „ „	- - - 4 B
K_1 closed and K_2 closed	„ „ „	- - - B

As in the standard quadruplex, key K_1 controls the polarity of the current going to line, but the depression of K_2 decreases the out-going current, irrespective of its polarity, from 4 B to B, or, in other words, cuts off the battery 3 B altogether. The pole-changing or double-current transmitter T_1 is the same as in fig. 4, and the relay R_2 is the same as that already described and illustrated

in fig. 5. The connections of the local circuit and sounder are direct, as shown by wires 22 and 23, the local relay or repeating sounder of fig. 2 being discarded.

The only matter requiring detailed explanation is the action of the relay R_2 .

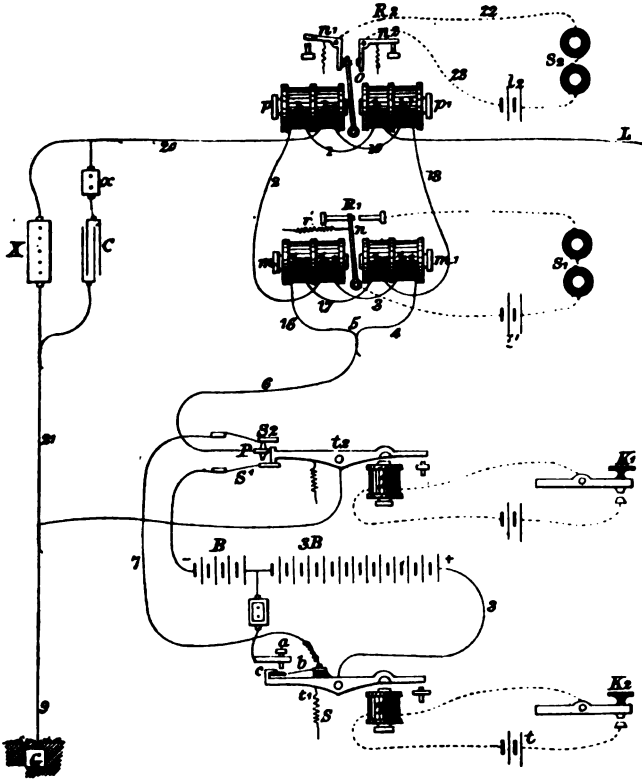

Fig. 6.

When both keys are at rest the positive current of both batteries (+ 3 B + B) is passing over the line, and the polarized armature is pressed against the contact lever n_1 , which yields, and thus allows it to separate from the contact lever n_2 , and the circuit of the sounder S_2 is broken. When K_1 is closed the polarity of the entire battery upon the line is reversed, and the armature passes over to

the other side and presses against n in the same manner, so that the sounder S_2 cannot be operated by the stronger currents of either polarity.

But the depression of the key K_2 , in either case, decreases the current until it is unable to withstand the tension of the springs of the contact levers $n_1 n_2$, and thus the local circuit through the sounder S_2 is completed, and the latter consequently responds to the movements of key K_2 .

In the summer of 1875 Mr. F. W. Jones, of Chicago, applied the differential arrangement of circuits to the apparatus shown in fig. 1, but without the auxiliary helices r upon the relay R_2 , or the condenser c , which serves to actuate them. A condenser is, however, placed between the two relays, one set of plates being connected to the main and the other to the artificial line. This is charged by the incoming current during the reception of each signal, and discharges whenever the polarity is reversed through both coils of the neutral relay R_2 .

The arrangement for repeating from one quadruplex circuit into another is very simple in principle, and consists in placing the two transmitters of one line in the same local circuits with the corresponding receiving sounders of the other line. By this arrangement New York is enabled to carry on four distinct communications simultaneously with St. Louis, a distance of about 1,100 miles, by means of a quadruplex repeater at Pittsburg; and with Chicago, 1,000 miles, by means of a repeater at Buffalo.

The extra means of communication created by the use of the duplex and quadruplex apparatus has been christened "phantom wire."

The Western Union Company have the quadruplex in use upon thirty circuits, and the duplex upon forty circuits, embracing altogether 21,917 miles of actual wire, and 37,358 miles of phantom wire, the whole representing 59,275 miles of actual and phantom wire. Various combinations of circuits are made by the use of the duplex and quadruplex apparatus which greatly add to their practical value. For example: The Boston and Buffalo wire is 550 miles in length. A set of quadruplex repeaters is placed at

Albany 200 miles from Boston and 350 miles from Buffalo, and the wire is worked as follows:—Boston sends to Buffalo and Buffalo sends to Boston, Boston sends to Albany and Albany sends to Boston, Albany sends to Buffalo and Buffalo sends to Albany, all simultaneously. This arrangement is also used, among others, upon the New York, Hartford and Providence circuit; New York, Bridgeport, and New Haven circuit; New York, Pittsburg, and St. Louis circuit; New York, Pittsburg, and Cincinnati circuits. Upon some other circuits the following combination is used. A wire between Pittsburg and Chicago—550 miles—is quadruplexed. At Pittsburg two sides of the quadruplex are connected with a duplex to Baltimore, and the other two sides with a duplex to Philadelphia. This enables Chicago to work duplex with Baltimore and Philadelphia.

DESCRIPTION OF M. AILHAUD'S SYSTEM OF DUPLEX WORKING, IN OPERATION ON THE MARSEILLES-ALGIERS CABLE.

Compiled from information furnished by Mr. R. K. GRAY and M. JULES W. F. GRAMACCINI, Chef des Transmissions, Marseilles.

The Marseilles-Algiers Cable, upon which this system is in operation, is 499 knots in length, and has a total resistance of 5,400 ohms, and a total inductive capacity of 140 microfarads.

The principle upon which this system is based is that of the Wheatstone bridge. For the purpose of giving greater facility of description, we may speak of the cable and the arm of the bridge to which it is connected as the third and first sides respectively, while on the other hand the artificial line and the arm to which it is connected may be termed the fourth and second sides of the bridge.

A battery of eight cells is brought up to a pair of reversing keys* in the usual manner, the one key being connected to earth direct and the other to a point midway between the first and second sides of the bridge, formed by resistances of 2,000 and 1,000 ohms respectively. The former is not connected directly to the cable, but through another resistance box, in which is unplugged a resistance of from 800 to 1,000 ohms. The advantage claimed for the introduction of this resistance is that a greater margin is thereby left for arranging the balance successfully. The first side of the bridge, namely that connected to the cable, is shunted, so to speak, by a condenser of 15 microfarads capacity. Its discharges are regulated, and their intensity held in check, by the intervention of an adjustable resistance, usually 2,400 ohms in the shunting condenser circuit.

The fourth resistance or artificial line † is also adjustable, varying from 4,800 to 4,900 ohms, one terminal being put to earth as usual.

In the bridge-wire is situated one coil of a differential galvanometer. Its other coil is placed in a separate circuit, one terminal being connected to earth and the other to a condenser of 20 microfarads capacity, which is again connected through a resistance of 11,000 ohms to the point where the second and fourth sides of the bridge-wire meet. Its influence upon the working of the cable will presently be shown.

Finally, to assist in the balance, a small auxiliary condenser of $2\frac{1}{2}$ microfarads has one side connected to earth and the other through a regulating resistance of 4,900 ohms to the point at which the other and chief condenser circuit ends.

When one of the two reversal keys is depressed a current enters the bridge and "splits" between the cable and the artificial line in

* A common mirror key is used, and it is said to give better results than the "constant resistance" key.

† This is not an "artificial cable," but resistance coils. Those actually employed are 40^Ω, 80^Ω, 120^Ω, &c. up to 8,400^Ω. It is claimed for this system that a balance is readily effected, even by learners, and that such steadiness is attained that an alteration of 40^Ω, more or less, does not affect the reading.

the respective ratio of 1 to 2. In so doing it charges the condensers and the cable to the potential of 8 cells. On allowing the key to rise, part of the charge in the cable, in returning through the reversing key to earth, causes a momentary current to traverse the galvanometer, manifesting itself on that instrument by a sudden deflection of the spot of light, constituting what is technically known as the "kick," and as such resembling in its nature a sudden current sent from the distant station. Signals are thus entirely confused, and, unless steps are taken to prevent the "kick," duplex working is rendered impossible. The part played by the condensers is to neutralise this kick by sending one in the opposite direction through the galvanometer. Thus when the key

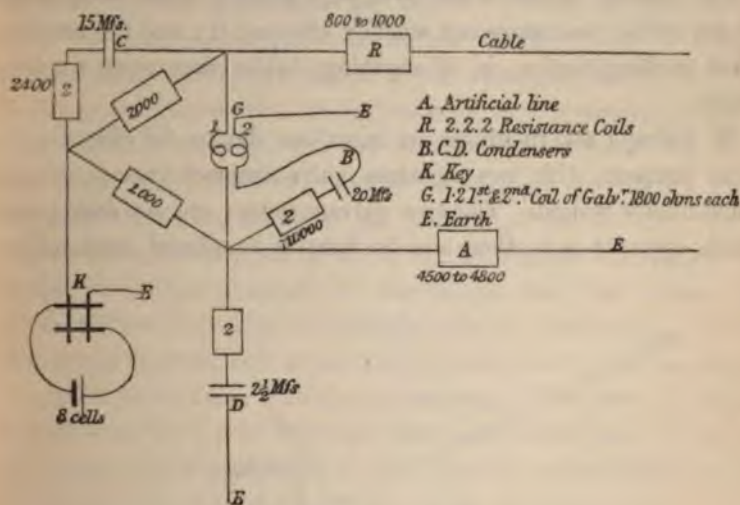

Fig. 1.

is depressed the condensers become charged like the cable, and when the key is again raised the charge is released and flows through the other coil of the differential galvanometer to earth, in such a direction as to oppose the effect of the charge as set up in the coil situated in the bridge-wire.

The reason for using a *differential* galvanometer in the manner

described is to effect a saving in condenser power. If situated like the auxiliary condenser, at the foot of the bridge-wire and directed to earth, the discharge would split, as does that from the cable between the galvanometer and one side of the bridge as a shunt, and the other arm as the main circuit, so that, shunted as the galvanometer is, a large portion of the discharge would be lost, more especially with the condenser, inasmuch as the first side of the bridge (that is to say, the greater resistance) is in circuit with the galvanometer as the shunt, and the second and less resistance as the main circuit. In the system in question, however, the entire discharge flows through one coil of the differential galvanometer, since the condenser is directly in circuit through it.

The existing balance is said to be very good, 40 ohms more or less on any of the resistances not sensibly affecting it; and the reading, when working duplex, is, if anything, better than when working singly.

M. Ailhaud also mentions an ingenious device for effecting the same purpose with two separate galvanometers instead of one differentially wound. The two galvanometers are set facing and nearly opposite each other, and the lamp is so placed relatively to

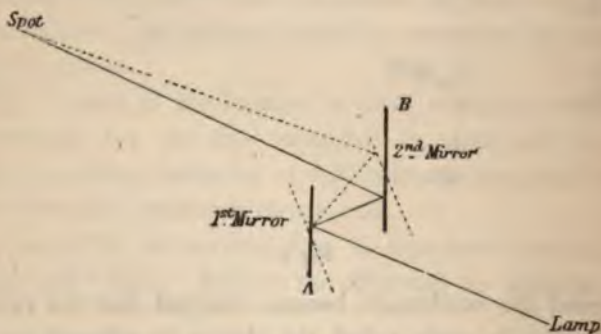

Fig. 2.

them, that, calling the mirrors A and B respectively, the image of the lamp will be reflected from mirror A on to mirror B, which again

reflects it on to a scale placed in the usual manner and in front of it. Mirror B being situated in the bridge-wire while the other is in the condenser circuit, it is obvious that so long as A's mirror remains still any deflection of B will produce a movement of the spot of light, for mirror A simply takes the place of the lamp at that spot. But should A also move, provided the reflecting couples are equal, the two will remain parallel to each other; and in that case, by a well-known optical law, the spot on the scale will not move.*

The PRESIDENT: We shall be glad to hear any observations upon these two valuable communications.

Mr. H. R. KEMPE: In considering the merits of the quadruplex system, it seems to me that the question is not whether such a system can be worked at all, but rather whether it can be worked economically. An examination of the apparatus before us would lead one to suppose that the adjustment and maintenance of the adjustment of the different parts could only be effected by skilled operators, which practically means highly-paid operators. Again, any one who is cognisant of the working of the ordinary duplex apparatus knows that a line which can be worked well singly with defective insulation would be unworkable with the duplex, and evidently would be also unworkable with the quadruplex. In fact, I may say further, that a line which would work with the duplex might be unworkable with the quadruplex. Here then is another objection to the use of the latter: the lines would have to be kept at a considerable expense in a very high state of insulation, a state which is unnecessary for the single or the duplex systems.

Taking these points into consideration, and also the apparent fact that each instrument of the quadruplex could not be worked at as

* Later information kindly furnished by M. Gramaccini states, that, in a special trial of speed made with M. Ailhaud's system on the Marseilles-Algiers cable, 40 messages were sent and 39 received in one hour, rectifications included. These were all 20-word messages, and, allowing for addresses, codes, &c. averaged 30 words each, figures being always repeated in letters. This would be nearly 2,400 words per hour, or 20 per minute, *in each direction*. The common average speed is said to be 60 messages per hour. From 500 to 550 messages, including some very long ones, are exchanged daily through this cable, which is seldom working more than 12 hours out of the 24.

high a speed as an instrument worked on the duplex system, it seems to me that the system would not be an economical one in its present state. It would have been interesting if Mr. Prescott had brought forward some statistics to show in what way the system is economically advantageous.

Mr. W. H. PREECE: It must not be supposed, because all the accounts we receive of quadruple telegraphy emanate from America, that we have been altogether idle in that field in England. Many telegraphists and electricians have been engaged at different times in experiments upon the method of sending four messages on a wire at the same time, and, though their efforts have not been crowned with practical success, their labours have paved the way for its ultimate introduction. It is so evident from what we hear from America that they have there been successful, that the Government have decided upon sending out some officers to America to examine into the working of the system in that country, and I proceed to America with Mr. H. C. Fischer on Saturday next. One of the objects of the visit is to examine the working of this system in actual practice.

With regard to duplex telegraphy, I have not myself been an idler in that field, and it may be interesting if I narrate briefly to the Society some of the chief historical facts connected with the introduction of that system into England. The statement has been made that some one in 1829 conceived the idea of the principle of duplex telegraphy. I can scarcely conceive that, whereas practical telegraphy did not come into existence till the year 1837, anybody could have conceived a practical system of duplex telegraphy in the year 1829.

The inventor, or rather the author, of duplex telegraphy proper unquestionably is Dr. Gintl, of Vienna, who in 1853 brought out the system by which it became practicable to send messages in opposite directions on one wire at the same time. He experimented in 1853-54, and, although his system was not what would now be called practicable, it was sufficiently practicable to justify electricians and telegraphists carefully to examine into the principle. The result was, that in 1854 Frischen of Hanover and Siemens and *Halske of Berlin* so modified the compensating circuit of Gintl's

system, that a real practicable form of duplex telegraphy was introduced. Accounts reaching England of this success led practical electricians of that day to more or less study the subject. Amongst the rest I plunged into it, and as the result of study and experiment in the year 1855 I devised a different form of duplex telegraphy, which was experimentally used between Manchester and Liverpool, and subsequently between Southampton and Cowes. At the same time the system of Siemens and Frischen was practically applied on a short line between Manchester and Altrincham, and Mr. De Sauty, who conducted the experiments, devoted his attention to the solution of some of the intricate problems that arose from its working. However, in those days the resistance of the lines and the character of the insulation was such, that the practical working on such a short line as twelve miles was such as to lead them to abandon the system. In 1858 Mr. Farmer in America introduced a new mode of duplex working by opposing currents on the equilibrium system, but it was not practically applied. In 1863 Mr. Möder of Berlin suggested a mode of duplex working on what is known as the Wheatstone bridge principle; but there is no distinct evidence that it was practically tried on any existing line. Indeed, it was not till 1868 that duplex telegraphy can be said to have attained what may be called its present practical form, and it was then that J. B. Stearns, in America, having studied what had been done before, and examined the working of the Wheatstone bridge, and the differential systems on existing lines, found out the cause of the difficulty which had hitherto existed with regard to electro-static induction, and he applied condensers which had been previously introduced by Mr. Varley in submarine cables. It was this application of conductors by Stearns in 1868, and improved by him up to 1873, which has rendered duplex telegraphy what it is now, one of the greatest improvements, and one of the greatest steps in the progress of telegraphy within our knowledge. Of course, the great difficulty in the system was in its application to submarine cables, and, though Stearns applied it to short cables in America, it was not till Mr. Muirhead in 1874 introduced his peculiar form of condenser that the difficulty of working long cables was practically surmounted. I am sorry that

pending legal proceedings has prevented Mr. Muirhead entering into the explanation of his system this evening; however, I have no doubt at one of our meetings next session he will favour us with a narrative of the experiments he made, and give us a history of the numerous interesting facts of which he is in possession. Mr. J. R. Winter, of the Madras Railway, has devoted a good deal of attention to the working of the duplex system, and the peculiarity of his system has been not only the introduction of Farmer's method of opposed currents, but the introduction of induction coils to compensate the effects of static discharge.

Then again Mr. Schwendler has devoted great attention to the introduction of the duplex system on very long lines. In India they meet with difficulties of working which we do not experience in England. For instance, they work duplex from Kurrachee to Calcutta—1,500 miles. Very few ever conceive in their minds the distance between Calcutta and Kurrachee. We are apt to form a notion of distances by the length of lines we see on maps, forgetting the fact that maps are drawn to different scales. When it is known that this system, worked in India, is the same as the distance between London and Constantinople, you have a better notion of the length of circuit worked duplex by Mr. Schwendler's double compensation system.

An Italian named Vianisi, in 1874, introduced another method of working duplex, which is in fact the bridge method, excepting, instead of making arms, or two branches, to the coils, he makes these arms the branches of the balance; and Mr. Gerritt Smith, D'Infreville, and others in America, have also in various ways modified the system so as to render duplex telegraphy practicable for all lines and countries.

By this rude sketch you will see that, like all great mechanical improvements and achievements in practical telegraphy, duplex telegraphy has been gradually and by progressive stages effected, till it has come into very extensive use indeed. I think, in the Post Office, we have from 150 to 160 circuits working duplex. In fact duplex telegraphy has ceased to become a wonder. It is really as simple a mode of working as any ordinary single-needle circuit or any ordinary sounder-circuit, and it has been, by the persistence

of those gentlemen I have named, in the addition of improvement to improvement, and by that process which is called the survival of the fittest or the process of evolution, that Gintl's first idea of sending messages in opposite directions on one wire at the same time has become a great practical fact. It has been by the united efforts of all these names I have mentioned, and by the strict application of scientific methods, that we have succeeded in paving the way for multiplex telegraphy.

Mr. VON FISCHER TREUENFELD: I have nothing to say with regard to the two papers, but, as Mr. Preece has brought forward the question of the history of the duplex system, I think I am bound to make a few additional remarks, which perhaps may bring the earliest history of duplex telegraphy into a different light than is generally considered. The very first duplex telegraph which was actually successfully worked was in May 1854, between Hanover and Göttingen, and what I want chiefly to show is that the general idea that duplex telegraphy only became practically successful after the introduction of Stearn's condensers is I believe decidedly erroneous, and I am sorry that Mr. Preece supports that idea. It may be interesting to know that in November 1854 Dr. C. W. Siemens took out the first English patent for this system, and during the first three years of its invention, that is, from 1854 to 1856, Messrs. Siemens and Halske fitted out no less than ninety telegraph stations with duplex apparatus in Germany, England, Holland, France, Austria, Denmark, and Chili. Therefore I think it may be said that duplex telegraphy was fully established as practically successful as far back as 1856, and, if it did not come to the high state of perfection to which it is now brought, the only reason has been that there was no necessity for obtaining the highest working value from each single telegraph wire.

The PRESIDENT: We are much indebted to Mr. Prescott for this paper and the interesting remarks it has elicited, especially those relative to the history of duplex telegraphy by Mr. Preece, supplemented by those of Mr. Treuenfeld. I confess myself, looking at the subject of quadruplex telegraphy as a dilettante electrician and an amateur in telegraph matters, I have shared with Mr. Preece the difficulty of forming any very clear conception of the some-

what perplexing details and diagrams which have been placed before us to-night; but after what has been told us by Mr. Treuenfeld with regard to what was accomplished so far back as 1856 in duplex telegraphy, although it afterwards, to some extent, laid dormant for a number of years, we may, I think, look hopefully for development of the system of quadplex telegraphy which has been brought before us, and to our future appreciation of it; more particularly when Mr. Preece, after his return from America, gives us a practical and thorough account of the merits of the system, and what we may expect from it. I have now to ask you to award your thanks to Mr. Prescott for his very interesting paper on Quadplex Telegraphy. We are also indebted to M. Ailhaud for the valuable information he has afforded with regard to the system of duplex employed by him.

Mr. F. Gorham Ticehurst was transferred from the class of Associates to that of Members.

The following Candidates were balloted for and duly elected:—

FOREIGN MEMBERS:—

Thomas Swinyard.
G. H. Grace.
P. P. Hauff.

MEMBERS:—

Daniel W. Gott.
Dr. Engen Obach.

ASSOCIATES:—

H. N. Blackwood-Price.
F. P. Stevens.
Henry Stevens.
Colin Brodie.
Lieut. Nesham Lloyd (82nd Regiment).
B. Sivemmer.
Alexander Glegg.
James Beresford.

The meeting then adjourned.

ORIGINAL COMMUNICATIONS.

NOTE ON ELECTRO-MAGNETS EMPLOYED IN TELEGRAPHY.

(Translated from the French).

It is possible to reduce materially the magneto-induced current arising in relay coils, thereby increasing the speed of working, without altering the construction of the electro-magnet or varying the battery power.

I arrived at the modification detailed below whilst carrying out some recent experiments with the object of ascertaining the resistance of the coils in relays which give the best results. I propose now detailing those only which bear on the diminution of the current of induction.

I have two of Siemens' polarized relays, varying considerably in resistance, one giving 600 and the other 2,500 Siemens units. I had them joined to a cable giving a resistance of 4,000 units, using the weakest possible battery current in order to judge better of the results, the same power being employed with both relays.

With the relay giving 600 units' resistance, readable signals could be obtained at a fair speed, but the regulation needed constant attention and alteration, on the slightest variation in the signals, style of sending, &c.

With that giving 2,500 units, signals were no longer readable at the same speed. They became utterly unintelligible, and they could only be read at the slowest possible rate of sending, and then with extreme difficulty, notwithstanding the relay, giving 2,500 units, approached more nearly the theoretical conditions for obtaining the maximum effect under the given conditions.

The latter relay in these experiments had its coils connected in the usual manner. I then had them joined in duplicate arc, thereby obtaining a relay giving 600 units, or approaching in

resistance the conditions established in the first experiment. The result, however, was different, good signals at a high speed being obtained without the necessity for altering the adjustments that existed in the first instance. This fact noted, I then made the following experiments:—

Firstly. The 2,500-unit relay was joined up in duplicate arc, thus giving a resistance of 600 units. Its adjustment was gradually altered, until signals from a steady manipulator just ceased to be visible; the coils were then connected up in the usual manner, when, without altering the adjustment, signals appeared, but confused and unreliable. Hence under this form the magnet exercised greater attractive force, which conforms to the accepted theory, but signals were not clear and distinct.

Secondly. The relay being joined up in duplicate arc, was so adjusted as to receive dots at great speed, then, the connections being altered as before, the dots were converted into dashes more or less long.

Thirdly. With the 600-unit relay signals were unreadable at the rate of sending in experiments 1 and 2, and the speed had to be diminished.

From these results it becomes evident, that, to obtain the highest rate of transmission with a given resistance, it is preferable to join up the coils of a relay in duplicate arc, to adopting the usual form.

I think the explanation of these phenomena is due to the fact that the induced current has but half the potential when the coils are joined up in the former manner that it has in the latter.

Thus, take an electro-magnet with its coils joined up in the common manner, each coil having a resistance = r units. The resistance of the relay then equals $2r$ under the influence of the line-current, each coil will develop an electromotive force = e , the current of induction traversing the line after each signal being represented by the usual formula

$$i = \frac{2e}{2r + R}$$

R being the resistance of the line. The two coils act like two cells of a battery joined up continuously.

Take now an electro-magnet joined up in duplicate arc, each coil having a resistance of $4r$ units. The two coils will then in this case have a united resistance of $2r$. The whole resistance of the circuit remaining unaltered the line-current will have the same strength as before, but, being divided between the two coils, the current through each will have but half the strength it had in the former case; as, however, the resistance in each coil is four times what it was before, there are therefore twice the number of turns round each, and, the magnetic attraction of the relay varying as the strength of the current and the number of turns round the coils, it follows that the magnetism developed is the same in both instances under experiment.

Let us now examine the induced current: each coil will as before develop a current with an electromotive force e , as this force varies with the strength of the current and the number of turns in the coil. The resistance of the coil, however, is now $4r$. Hence we have two elements, each with an electromotive force e and a resistance $4r$, joined up for quantity on a circuit R . They act therefore as one element with an electromotive force e and a resistance $2r$, the strength of the induced current through the circuit being in this case

$$i' = \frac{e}{2r + R}$$

whence

$$i = 2i'$$

Hence, by joining up the coils in duplicate arc, without varying the total effective resistance of the relay, its magnetic effect, or the battery employed, the induction current is reduced by half.

The induced current being one of the principal obstructions to fast sending, speed will obviously be notably increased by adopting this form of electro-magnet for relays.

The question of the resistances which give the maximum effects with this form of relay will form the subject of another paper.

(Signed) EMILE LACQINE,

Constantinople, July, 1876.

ON ELECTRO-MAGNETS FOR USE IN TELEGRAPHY.

(Translated from the French.)

What should be the resistance of an electro-magnet, so that it should develop its maximum effect?

This question, notwithstanding the attention it has received, has not by any means met with a satisfactory solution, so far as electro-magnets for long lines are concerned.

It is well known that for long circuits it has been found practically advantageous to make the resistance of the electro-magnet much less than theory would indicate, even when allowance is made for leakages through defective insulation. To obtain the maximum magnetic effect the resistance of the electro-magnet should equal that of the circuit in which it is interposed; but will these conditions hold good when the object is, not to obtain the maximum development of magnetism, but the maximum number of clear signals in a given time? As will be seen further on, there is every reason to answer this question in the negative; and in actual practice it will be found, that, especially in apparatus designed for great speed, the widest departure from the accepted theory is observed.

Sufficient magnetic force is readily evolved for working the delicate instruments employed on long circuits without the use of exaggerated battery power; the great difficulty experienced being the slow speed of transmission of independent and successive signals; and attention should therefore be directed towards any means of increasing this speed. Amongst others may be cited—

1. Decrease in the resistance of the circuits;
2. Decrease in the inductive effects of the electro-magnets;
3. Decrease in the static charge and increased facilities for discharge.

The third condition, so far as it relates to the decrease of the static charge, can only be affected by modifying the character of the line. The consideration of this is foreign to the object of the present paper, but it will be seen that the result at which we are

aiming greatly facilitates the discharge by considerably reducing the resistance of the electro-magnets.

The second condition has already been treated of in a former paper, in which it was shown, that by joining up the coils of a magnet in duplicate arc instead of continuously, as is the ordinary practice, the inductive effects can be reduced by half, without any diminution of their resistance or their magnetic force.

It finally remains to consider the first method, that is, the decrease in the resistance of the circuit.

It is known that the propagation of a current becomes more retarded as the resistance of the circuit increases, and that the period of propagation, for delicate purposes, is nearly proportional to the resistance of the circuit.

Mr. R. Sabine has proved by a series of admirable experiments that the speed of transmission diminishes with the resistance of the circuit, and that the resistance of the receiving apparatus has a great influence on the speed.

To sum up; the speed of transmission varies inversely as the total resistance of the circuit.

The resistance of electro-magnets should therefore be decreased, but this decrease diminishes their attractive force, which demands an increase in battery power to maintain the standard efficiency.

Certain relations should be established between these two variables, and we propose investigating the conditions which result in the greatest speed, without exceeding the limits imposed by practical telegraphy.

First, suppose a line perfectly insulated, with a resistance R sufficiently great to admit of our disregarding the resistance of the battery, though this is not indispensable.

Let e equal the number of cells necessary for working the relay satisfactorily, the latter being in the best condition for obtaining the maximum effect, that is, having a resistance R . The magnetic intensity will then be required by

$$\frac{ef}{2R}$$

f being the co-efficient of the relay.

The latter portion, however,

$$\frac{m}{(m^2 + 1)^2}$$

is the only one involved.

Differentiating and making it equal to zero we get for result—

$$m^2 = \frac{1}{3}$$

Hence the resistance of the relay R m^2 should be equal to $\frac{R}{3}$ to obtain the maximum effect, that is, the highest speed with the lowest power.

2. *Maximum possible Speed.*

In this case the cost of the battery is neglected, the object being to obtain the highest speed. To effect this m^2 must be reduced as low as possible, E being increased so as to maintain the necessary magnetic force. There are, however, practical limits to this increase, for the number of cells cannot be multiplied indefinitely, as a period arrives when the current becomes too variable, and the maintenance of the battery is very difficult. Let E be this limit, then equation 1 becomes—

$$\frac{ef}{2R} = \frac{efm}{R + Rm^2}$$

Whence, replacing $\frac{E}{e}$ by M,

we get
$$m = M - \sqrt{M^2 - 1} \dots \dots \dots 4.$$

It will be seen that the greater M becomes, the more m , and consequently m^2 , or the resistance of the relay, diminishes, but in a greater ratio. Take for example a long circuit, which requires 100 cells to work it. Increase this to 125, which is about the maximum battery power that can be practically used for telegraphy, we get—

$$M - \frac{125}{100} = \frac{1}{4},$$

and from equation 4

$$m = \frac{1}{2} \text{ whence } m^2 = \frac{1}{4}.$$

Thus, by increasing the battery by $\frac{1}{4}$, we may reduce the resist-

ance of the relay four times, without diminishing the magnetic force.

Further it will be observed, that for long circuits this value $m^2 = \frac{1}{4}$, which is almost a limit, approximates closely to the value $m^2 = \frac{1}{3}$, which represents the useful effect, although for short lines very different values may be obtained.

When $m^2 = \frac{1}{4}$ we get as the number of dots

$$N = \frac{2 A}{m^2 + 1} = \frac{16}{10} A.$$

When $m^2 = \frac{1}{3}$ it becomes

$$N = \frac{2 A}{m^2 + 1} = \frac{15}{10} A.$$

We have hitherto considered the case of a line perfectly insulated, but the same results follow when leakages are taken into account.

Take a wire with a resultant loss giving a resistance c . Let a be the resistance between the battery and the resultant leakage, and b that between the latter point and the relay. The magnetic intensity will then be represented by the formula

$$\frac{e f c}{ab + ac + bc + r(a + c)}$$

r being the resistance of the relay.

Suppose, as before, the relay have a resistance equal to the remainder of the circuit, we then shall have

$$r = \frac{ab + ac + bc}{a + c}.$$

Let $ab + ac + bc = B$, and $a + c = D$,—
the expression then becomes

$$r = \frac{B}{D}.$$

The total resistance is then $\frac{2B}{D}$ and the magnetic intensity

$$\frac{e f c}{B + r D} = \frac{e f c}{2 B}.$$

Modify the resistance r , make it equal to $r m^2$, and let E be the new battery, then—

$$\frac{E f m c}{B + B m^2} = \frac{E f m c}{B(m^2 + 1)}.$$

For the new magnetic intensity to be equal to the former, we must make

$$\frac{e f c}{2 B} = B(m^2 + 1),$$

whence results

$$E = \frac{e(m^2 + 1)}{2 m}.$$

The new resistance, instead of being as hitherto $\frac{2 B}{D}$, becomes

$$\frac{B}{D} + r m^2 = \frac{B}{D} + \frac{B m^2}{D} = \frac{B(m^2 + 1)}{D}.$$

Further, let A be the number of dots per second in the first case, we now get—

$$N = \frac{A 2 B}{D} \times \frac{D}{B(m^2 + 1)} = \frac{2 A}{m^2 + 1},$$

the useful effect being—

$$\frac{N}{E}.$$

Replacing N and E by their last values, this is represented by

$$\frac{4 A}{2} \times \frac{m}{(m^2 + 1)^2},$$

being the same value as in a perfectly insulated line, the maximum useful effect being still

$$m^2 = \frac{1}{2}.$$

This result is therefore general, and it shows that to obtain the maximum useful effect the relay should have resistance of $\frac{1}{2}$ the circuit.

For less delicate apparatus it is generally admitted that the speed of transmission varies inversely as the square of the resistances, instead of as the resistances alone. The same reasoning proves that for such cases the maximum is obtained when $m^2 = \frac{1}{2}$, that is, when the relay is $\frac{1}{2}$ the resistance of the circuit.

For ordinary apparatus, a mean value of $m^2 = \frac{1}{2}$ may be accepted.

Applying the above results to general cases of long circuits, with delicate apparatus, we see that the resistance of the relay should be

$$r = \frac{1}{3} \times \frac{ab + bc + ac}{a + c}.$$

On well-maintained lines the resultant of the leakage should be in the middle, neglecting the resistance of the battery, we can then make

$$a = b,$$

which gives $r = \frac{1}{3} \times \frac{a^2 + 2ac}{a + c} = \frac{1}{3} \left(a + \frac{ac}{a + c} \right).$

If the insulation be perfect, then c is infinite, and

$$r = \frac{1}{3} \times 2a = \frac{R}{3},$$

R being the resistance of the perfect line; we thus find another confirmation of the first investigation.

Take a case with moderate leakage. Let $c = 6a$, then

$$r = \frac{R}{3 \cdot 2}$$

with $c = 4a$ it becomes $r = \frac{R}{3 \cdot 3},$

$$c = 2a \quad ,, \quad r = \frac{R}{3 \cdot 6},$$

$$c = a \quad ,, \quad r = \frac{R}{4},$$

which last represents a loss of half the current.

Lastly, when $c = \frac{a}{2}$, showing a loss of $\frac{2}{3}$ the current, we get

$$r = \frac{R}{4 \cdot 5}.$$

This is the proportion of loss taken by Mr. Hughes in his admirable experiments on electro-magnets. In certain experiments by this gentleman, with the object of ascertaining the proportionate resistance for electro-magnets, he found that with a line giving 500 kilometres resistance (old French unit) the best results were obtained with a resistance of 120 kilometres on the magnet. The formula gives

$$r = \frac{R}{4 \cdot 5} = \frac{500}{4 \cdot 5} = 111 \text{ kilometres.}$$

If the battery were taken into consideration, this number would approach very closely to 120 kilometres.

The new rule, therefore, which indicates that for delicate apparatus the relay should have $\frac{1}{3}$ the resistance of the circuit for its maximum useful effect, agrees with experience and practice.

It remains now to show that the number of elements necessary to work these relays is not excessive, and that it is not beyond the bounds of ordinary practice.

In the equation

$$E = \frac{e(m^2 + 1)}{m}$$

if we replace m and m^2 by their values $\sqrt{\frac{1}{3}}$ and $\frac{1}{3}$, we get

$$\frac{E}{e} = 1.15.$$

Thus, by increasing the ordinary battery power by 15 per cent., we can reduce the resistance of the relays to $\frac{1}{3}$ the resistance of the circuit, and obtain an increase of two or three times the speed, for in the equation

$$N = \frac{2A}{m^2 + 1}$$

by replacing m^2 by its value we find

$$N = \frac{3}{2}A.$$

Finally, it follows from this and the preceding investigation that the coils of electro-magnets should be joined in duplicate arc, and that the resistance of delicate relays should be $\frac{1}{3}$ the resistance of the circuit; whilst for less delicate apparatus, it should be $\frac{1}{4}$ or $\frac{1}{5}$ only. Further, that in practice, taking a mean loss on long lines, through defective insulation, of $\frac{2}{3}$ of the current, the resistance should be only $\frac{1}{4}$ or $\frac{1}{5}$ of the normal resistance if the conductor is supposed to be perfectly insulated.

For apparatus in which speed is no object, but in which the maximum magnetic force is required, the resistance of the relay should equal that of the line.

(Signed) EMILE LACOINE,
 Chef de la division technique des
 Telegraphes.

Constantinople, January 4, 1877.

TELEGRAPHY IN NEW ZEALAND.

By W. H. FLOYD, M.S.T.E.,

Electrician to the New Zealand Government Telegraph Department.

With the hope that some account of the character of Telegraph construction and management in New Zealand may be interesting as helping to show the various conditions under which Telegraph Officers have to work, in different parts of the world, to arrive at the one result of establishing and maintaining Telegraphic communication between distant points, I offer the following notes of an experience in this colony extending over seven years.

All the telegraph lines in New Zealand are in the hands of the Government. They are under the control of a Minister of the Cabinet, who is styled Commissioner of Telegraphs, and who is, usually, Postmaster-General. The chief permanent officer of the department is the General Manager, to whom all other members of the staff are directly accountable.

For maintenance and supervision of lines there are the electrician, who is also a district inspector, four inspectors of districts, and about forty linemen. The linemen are so placed that any two of them riding on horseback towards each other from their respective stations will meet in from six to eight hours.

Each inspector is provided with a Siemens' Universal Galvanometer, a "ten thousand" box of resistance coils, and all necessary appliances for testing land lines. It is his duty to test all the lines under his charge for wire resistance, and for insulation, at least once in every month, and to take steps to remedy any deterioration that the testing may make apparent before an actual interruption to communication occurs.

The following record is copied from an Inspector's Test-book :—

Date.	Name of Section between what points.	Mileage of Section.	No. of Wires.	All in Siemens's Units.				What Hour of Day the Tests taken.	Description of Weather		Remarks.
				Total Copper Resistance of Wires.	Copper Resistance per Mile.	Total Insulation of Wires.	Insulation per Mile.		At Home Station.	At distant Station.	
1876		Miles	Looped				a.m.				
Dec. 20th	Tauranga to Napier	Loop 388	1 and 2	5,820	15	290,000	8-20	Fine	Fine		
"	" Wainui	Loop 570	"	8,520	14.9	156,700	"	"	"		
"	"	"	1 and 3	8,760	15.36	"	"	"	"		
22nd	" Grahamstown	Loop 152	1 and 2	2,529	16.6	17,770	8-0	Drill and Overcast			

At the end of June, 1876, there were 3,154 miles of telegraph line, carrying 7,247 miles of wire, in operation in the Colony, and the number of telegrams forwarded during the preceding twelve months was 1,051,086. Number of telegraph stations 142. Staff, including all grades, 567 persons.

Construction of Lines, &c.

Telegraph poles in New Zealand are almost universally cut from Totara, or from Kauri.

Totara (*podocarpus Totara*) is found throughout the Colony; it usually attains its greatest dimensions on rich alluvial lands, or on dry hill-sides of low elevation. Large specimens are found in the northern part of the North Island, but Totara does not occur in abundance there; it is found in the greatest quantity and of the best quality in the southern part of the North Island, where trees are occasionally from 8 to 10 feet in diameter and 70 feet in height. The average size is from 4 to 6 feet in diameter, and from 40 to 50 feet in height. Totara is a highly-valued timber in the Colony from the durability of its heart-wood in the ground, and it is in great request for marine wharves and bridges, from the fact that, when driven with the bark intact, it has the power of resisting the attacks of teredo for a considerable period. Kauri (*dammara Australis*) is only found in the northern part of the North Island. It attains to the height of from 120 to 160 feet, and clean, symmetrical trunks may be seen from 50 to 80 feet in length, varying from 5 to 12 feet in diameter. The Kauri has acquired a reputation above all other new Zealand timber, from its value for masts and other purposes of naval architecture.

All telegraph poles are sawn. The usual dimensions are—length, 20 feet; thickness at the butts, 8 inches square, tapering to 6 inches square at the tops. The greatest care is exercised in examining poles before they are received for use on the lines, and a stringent specification, prescribing heart-wood and freedom from knots, shakes, or any other imperfections, is rigidly insisted upon. This examination is of great importance, especially as regards absence of sap-wood, for, although the heart-wood of both Totara

and Kauri have been proved to be very durable in the ground, the sapwood of either timber will decay almost immediately, and poles containing it in any quantity will be quite rotten at the ground-line in from two to three years after their erection. The pole-arms are sawn from the Rata (*metrosideros robusta*), a dense tough wood, found principally in the North Island. It is not durable in the ground, but hardens with exposure in air, and is very suitable for pole-arms. Large quantities of arms are sawn, and bored, and stacked at Wellington, where they are seasoned, and whence they are distributed over the colony as occasion requires.

Pole-arms are bolted to the poles with $\frac{5}{8}$ galvanised iron bolts, which, with galvanised iron pole-caps, No. 8 iron line wire, No. 11 homogeneous wire for river spans, &c., No. 16 binding wire, and No. 8 Varley's brown stoneware insulators, are imported from England. Until lately the Varley insulator was ordered for all new lines and for renewals, but a few hundred white "Prussian insulators" have been recently imported, and are in course of trial. A few porcelain shackles, also imported from England, are in use, but their employment is not encouraged, sufficient strength for sharp angles being obtained with steel-pinned insulators, two of which are used for each wire at every angle where they are deemed to be necessary. The plan pursued is to bolt two arms on to the pole, one on each of its sides that face up and down the line. The two arms are placed exactly opposite to each other, and the arm-bolt passes through both of them and through the pole. An insulator is placed at each end of each arm, so that each wire can be tied to two insulators at every angle.

Struts and stays, being liable to injury from cattle in open country, are avoided as much as possible, and it is sought to make every pole strong enough to stand of itself the greatest strain that can be put upon it by the worst weather.

For angles it is ordinarily found sufficient to lay two poles together, so as to double the thickness of the pole in the direction of the strain of the angle, and to set such double pole five feet deep, with a stout block at its back butt, and a similar block at the front, about a foot below the ground-line.

Poles are usually set four chains apart over level country, but in

broken country the spans are of irregular lengths to suit the character of the ground. No fixed rule can be applied, but it is sought to arrange the poles so that the wire, when strained to a liberally-calculated safe tension, will rest lightly upon its arm.

The longest span I am personally acquainted with in the colony is 36 chains—it is across a deep gully, and its wire is the ordinary No. 8 line wire. I know many spans that are within 6 to 16 chains of the same length, and there has never been the slightest trouble with any of them since their erection.

On the lines constructed under my supervision all spans of more than 8 chains in length are in the straight. This rule may sometimes cause an angle to be necessary at only 2 chains distance from the long span, but it avoids a fruitful source of breakdown. At each end of spans exceeding 12 chains in length two poles are placed—they are called braced poles, and when completely fitted they resemble the letter **A** in appearance. Each pole is set in a separate hole. They are 4 feet apart at their bases, and 2 feet apart at their tops. Two Rata arms, one on each side, up and down the line, tie the poles together, and also bear the line-wires. A bolt passes through both arms, and through each pole. This arrangement has been used by me in hundreds of cases during the past seven years, and it has never given trouble. A great deal depends, however, upon carefully setting the poles.

For spans over navigable rivers stout lower masts, fitted with ordinary telegraph poles for topmasts, have been used for heights not exceeding 60 feet, but for greater heights endeavours have been made to provide a support for the wire, that may be carried to any requisite height, and at the top of which an ordinary lineman can work, in perfect safety, during the most stormy weather. For these purposes four turrets, square on plan, tapering from 20 feet width at the ground-line to 8 feet width at their tops, and about 100 feet high, were erected for river crossings near the Thames goldfields in 1870, under Mr. Alfred Sheath's direction. The turrets were built upon stout Totara piles driven 20 feet into the banks of the rivers. The sides of the superstructure were formed by light wall-plates of Kauri placed at intervals of 12 feet, and connected by Kauri studs that were tied together, and to the wall-plates by

diagonal braces, also of Kauri. On every set of wall-plates there was a flooring, and a ladder was fixed between each floor, so that a lineman could pass from the base to the top of the turret almost as easily, and quite as safely, as he could go up-stairs in a house. Iron bolts and bands were used at the angles to bind the whole timber structure together.

In 1872 the writer designed a turret that, by being triangular on plan, dispensed with one-fourth of the material required by the square pattern, and offered less resistance to wind. Two turrets of this form were built in the Bay of Plenty district in 1872-3, and have given every satisfaction.

A triangular turret, 100 feet high from base to top, erected at Maketu, near Tauranga, cost £175. The cost included three coats of paint for all the woodwork.

The advantages of the turrets over tall masts will be obvious. It is in stormy weather that telegraph lines are most likely to fail, and long spans over navigable rivers are often more than ordinarily exposed to strong gusts of wind that may break the wires. Should a break occur it must be repaired at once, and any man can go to the top of a turret to work at the wires in any weather, while not one in a hundred would be found to venture to the top of a tall unprotected mast during a gale of wind.

Every telegraph pole is fitted with a No. 8 wire passing from a coil at its foot, up along one side of the pole, and to 6 inches above the pole cap. This wire is only used as a lightning-conductor at present, the necessity for leakage wires not having yet made itself urgently noticeable in New Zealand.

Offices are fitted on the Morse system with Siemens' polarised relays, recorders, galvanometers, and single current keys. Gravity batteries in glass jars are universally employed throughout the colony; for the longest circuits—about 600 miles—50 cells are required. A Siemens' plate lightning-guard is placed between each line wire and its instrument in every office. The bridge duplex system adapted by Dr. Lemon, the general manager of telegraphs in New Zealand, is in use on several circuits, and has been very successful.

So far, I have written of what is common to the whole telegraph

system of New Zealand. The same kind of timber, and the same sort of wire, insulators, &c., are employed throughout the colony, and one uniform standard of excellence for completed lines is insisted on, no matter what may be the character of the country over which the lines pass.

Every line must be constructed of the best materials, and must be thoroughly well set, and protected from every known possibility of injury. If, from the nature of the country, these conditions are difficult of fulfilment, that is a matter for the constructor: he has to be sure that his work fulfils them—how he manages it is entirely his own affair.

Where well-travelled roads have been made before the wire was called for, telegraph construction is, perhaps, as simple a matter in New Zealand as in England, and offers no special features for description, but it frequently happens out here that the telegraph is the first evidence of progress shown in hitherto almost unknown districts, inhabited only by aboriginal natives. Under such circumstances the work required from the Telegraph Engineer becomes of a most varied, and often of a most arduous, character. He may have to cut a path through dense forest, to build temporary bridges, cut tracks contouring high hills, and make temporary roads across swamps, before any of his material or appliances can be placed on his line, and before supplies can be conveyed to where his men will be at work, and, worse than all, he may be met by Maori opposition that must be coaxed away. The Telegraph "Act" gives the constructor full powers for dealing with obstructionists, but those powers cannot be used in a country exclusively owned by Maoris, and where there is no white population. Force under such conditions is out of the question. Bribery is quite useless, for yielding to an exorbitant demand only invites one yet more extortionate. The only weapons to be used are tact, patience, and determined persistence. They do not often fail, but English human nature may be sorely tried in applying them.

The construction of new lines is invariably entrusted to officers of the Telegraph Department. The officer selected to construct a particular line receives instructions from the General Manager to connect two places by wire. If the intervening country has been

surveyed he receives plans, and any information the Government can supply him with. Often enough, however, it has happened that the country between the two places to be telegraphically connected has not been surveyed, for the reason that, until now, the Maori residents on the land have strenuously refused to allow a white man to haul a chain over it, or to bring a theodolite anywhere near them; therefore little or nothing has been known at head-quarters that would be serviceable as a guide to the constructor. His first proceeding is to repair to one of the points to be connected; he there collects all local information as to the character of the country, and makes arrangements to personally examine it with a view to selecting the best route for his line. The information he receives, and the length of line to be made, will determine what the nature of the arrangements for a personal examination of the country should be. In the following description I propose to show a course actually pursued successfully in the construction of a telegraph line, 220 miles long, passing, for a great proportion of its length, over sparsely inhabited, unimproved country.

Provided with such maps as could be obtained, and accompanied by a surveyor, and by an interpreter, who, in addition to a competent knowledge of the Maori language and customs, was an active, hardy man, accustomed to bush life, the constructor started from Auckland to journey northwards. All three travellers were well mounted, and a pack horse carried a tent, blankets, and food. They expected to find inns, or accommodation houses, or hospitable settlers along their line of route most of the way, but it was probable they would sometimes be far away from any habitation when night came on, and for such a contingency the tent, blankets, and food were provided—they were all required before the journey of examination was completed.

After five days the constructor had selected the route of the intended line for the first fifty miles, and the surveyor returned to Auckland to form a survey party to commence cutting a line along the course selected, and to peg off the position for each telegraph pole.

The constructor and his interpreter rode on, and continued, day after day, for six weeks, examining the country, making the acquaintance of settlers and Maori chiefs, and generally collecting all necessary particulars as to the various routes by which a telegraph line might be taken. Then they again rode into Auckland, and the constructor reported to head quarters at Wellington on the information he had gained during his journey, and made his recommendations.

He had found that, of the 220 miles of line to be erected, about 60 miles would pass through heavy timber scattered in patches along the whole length of the route. For about half the distance the country was sparsely inhabited by Europeans, the remainder was in Maori possession and occupation. Kauri trees were plentiful along most of the line of route, and were generally in convenient situations for the supply of telegraph poles from them. Spans over navigable rivers would be few, and the crossings had been selected where the river-banks were sufficiently high to make turrets, or specially designed poles, unnecessary. Nine towns and settlements were recommended as suitable places for telegraph stations, and preliminary arrangements had been made to secure a site at each. The various routes examined were described, and the reasons for and against their adoption minutely entered into. In selecting the route he recommended, the constructor was mainly guided by the considerations that more road-work had been done over it than over any of the others. More forest clearing had been completed, more of the rivers and creeks were bridged, and it was a route that would probably become the principal road through the country, and that would be gradually improved and supplied with bridges as settlements increased. These are important considerations in selecting a telegraph line in New Zealand, for well-kept roads and bridges are of great assistance to prompt repair of telegraph wires in cases of break-down, and maintaining roads and tracks, respecting which highway boards recognise no responsibility, may be a heavy charge upon the telegraph department, which must keep a track open to enable linemen to follow the course of the wires. The constructor's report was made in March, and on the

28th May he received orders from the Government to make the line he recommended.

Meanwhile the surveyor had been steadily pegging off the selected route for the past three months, and was progressing at an average rate of about a mile a day. Tenders were at once called for the supply and delivery at pegs, in accordance with a standard specification, of 4,500 telegraph poles cut from heart of Kauri or Totara. Tenders to be delivered in Auckland by July 7th, and all poles to be at pegs by December 31st in the same year. To encourage settlers along the line of route to tender for the supply and delivery of poles, the work was divided into seven separate contracts, a suitable number of poles being allotted to each contract from the experience gained upon the preliminary journey of exploration.

On the 1st of June a party of bushmen, under an experienced foreman, started to follow the surveyor's track, and make a clean clearing through the forest along the course of the intended line. And the constructor again rode through the country to examine the surveyor's work, and to make further arrangements for forest clearing. He found small settlers who were struggling to make homesteads for themselves very glad to take contracts to clear the timber near their locations. Thirty-two contracts for clearing were made with Europeans and Maories, varying from £5 to £500 in value, and all the work was well and faithfully performed by both European and Maori contractors. They contracted to knock down all trees that could possibly fall across the route of the wire, to make a clean clearing of all logs, scrub, &c. for a width of 20 feet on each side of where the wire would be, and to a radius of 30 feet at every pole-peg. These precautions, and the additional one (carried out by the erecting gang) of digging round all poles to a radius of 12 feet, and sowing the grass-seeds most suitable to the land, are most important for the preservation of the line from injury from falling trees, or from bush fires. It is characteristic of New Zealand forest, that, whenever a line is cleared through it, the trees on the edge of the forest along each side of the clearing speedily wither and fall; as some of the trees attain a height of

160 feet, and a diameter of 12 feet, the work to be done before a telegraph line through forest can be considered safe is often very heavy, and a serious addition to the cost of construction. Clearing forest in the North Island of New Zealand is made additionally difficult by the luxuriance and density of the undergrowth. In travelling through it before a road is formed, it is absolutely necessary to follow Maori tracks, and carry a tomahawk and bill-hook to cut new tracks, should the old ones have become blocked up by fallen trees. On the line under description, the forest clearing amounted to 5,860 square chains, and cost £5,323 6s. 8d. It was commenced on the 1st of June, and finished before the end of December in the same year. As I have said, the work was faithfully done by both Europeans and Maories, but getting the contracts made with our "brothers in brown" was, in the majority of cases, by no means easy.

The constructor found the first native over whose land the line would go, and with whom he had dealings, a thoroughly straightforward, honourable man, who made no difficulty about the necessary destruction of his timber, and who undertook a very heavy piece of clearing at a reasonable price. He was an influential chief, although only a half-caste, for his mother's blood had been especially blue; his father is not known to this generation, but is supposed to have been a whaler.

To be the son of a blue-blood mother, by any father, is however thought of far more importance than to be called the son of a great male chief by an inferior woman. Eru Nehua's good faith and example helped the constructor very materially when he came to deal with less honourable natives.

In nearly every other case the Maories demanded compensation for the destruction of their timber, or, where they had no timber, for the land that would be occupied by each telegraph-pole. The demands varied as to the amounts asked for, but they were always designed on a liberal scale.

In the case of timber clearing, the constructor consistently refused to pay compensation, but he invariably offered the Maori owners the privilege of doing the work on their own land, and

stated his price for it. To quote actual cases : where the constructor offered £300, the Maories demanded £2,000 ; where he offered £30, they asked for £200 ; and this kind of thing occurred at least a dozen times before the contracts were finally completed on the constructor's terms. One party of Maories held out for six weeks, and were very strenuous in their assertions that nothing should induce them to allow the wire to go on any but their own terms, but they gave way at last. In every case a fair value for their work was offered them in the first place, but the idea of compensation for destruction of timber was never entertained ; if it had been, the demands would have been enormous, and would have increased at every fresh patch of forest that had to be dealt with. There was no real case for compensation, for the timber was, in every instance where claims were preferred, either unmarketable or so difficult to get out to a market as to be practically valueless. In fern land the favourite demand per pole for permission to erect the line was £5. Patience and persistence, together with the greatest care that no injustice was attempted, nor any real cause for complaint given, by any of the telegraph construction party, while instant advantage was taken of every concession, at length overcame all difficulties without a penny of compensation being paid from end to end of the line. By the 7th of July the constructor was again in Auckland, and opened tenders for supply and delivery of poles at pegs. All seven contracts were at once taken up. The prices ranged from 17s. 3d. to 26s. 6d. for 20-foot poles, 25-foot poles 5s. extra.





The contractors went to work at once to fell trees, build sawpits, and engage sawyers for the pole-cutting, while the bush-clearing parties were increasing in number as the surveyor worked steadily forward with his pegging. By the end of October the delivery of poles commenced. Each contractor was supplied with instructions for laying the poles, in the following form :—

Section—Warkworth to Mangawai.

No. on Peg.	Poles.		
	20 ft.	25 ft.	
1	1	—	At Warkworth Telegraph office.
2	—	1	
3	—	1	Road.
4	1		
5 and 6	2	—	Angle.
7	1		
8	1	—	Creek.

As soon as pole-laying had fairly commenced, the arms, bolts, pole-caps, and wire for the line were shipped from Auckland to convenient ports, and thence laid along the line, by the help of drays where the roads were good enough, and packed on horses over parts of the route where drays could not travel. Instructions were issued to packers in the following form:—

Section—Warkworth to Mangawai.

No. on Peg.	Insulators. 	Arms. 	Pole caps. 	WIRE — coils.	Bolts.		Remarks.
					 8 in.	 10 in.	
1	6	6	6	1	4	2	
7	5	5	5	1	5		
12	5	5	5	1	5		
17 & 18	6	6	6	1	4	2	

The rude sketches of the various articles to be laid at pegs were made for the benefit of European packers who could not read very well, and of Maories who knew no English. The plan of laying

enough material at each heap to use up a bundle of No. 8 wire is preferable to that of placing each article exactly where it will be used ; there is less liability to loss, and the work of the packer is reduced, as he has not to leave the track to go to every pole. The extra trouble to the erecting gang is trifling, and is not nearly so great as the hindrance occasioned by finding single-pole articles placed at a double-pole angle, which is what will sometimes occur with the most perfect packers.

Next, a well-trying erecting gang, recently come from another line, was broken up into parties of two men, and each party of two proceeded to a section of the line indicated by the constructor, and hired labourers sufficient to make an erecting gang that should be able to put the poles up as fast as the contractors brought them on to the ground. One of each two men had to fit arms, pole-caps, and lightning conductors on all the poles, the other looked after the hole-sinking and pole-raising. In European districts it was not difficult to get labourers who quickly picked up the work, but in Maori districts the mode of proceeding was necessarily rather peculiar, from an English point of view, and sometimes troublesome. In order to avoid hindrance or opposition, the constructor arranged that the Maories from every settlement on the line of route should be employed to erect the poles over the ground they claimed to be theirs. Six young men were to be selected from each settlement, and were to be paid at a fixed rate of daily wages. Where the settlements were far apart this plan was perfect, for the natives were soon as smart at the work as white men, but when settlements were close together the plan was troublesome from the frequent change of labourers. Sometimes the same settlement would supply men for a whole week, and by that time some of the party would certainly think they could set a pole quite as well as their English foreman, but there were places where men came on to erect only half-a-dozen poles, and insisted that nobody else should be allowed to erect them. The land was theirs, and they alone should receive money for working on it. So they worked and were paid whatever proportion of a day's wages their working-time entitled them to. These frequent changes made the work arduous to the unfortunate European who had to supervise hole-

digging and pole-setting. It also gave a good deal of extra work and anxiety to the constructor, who found it necessary to personally superintend the work through the Maori settlements, in order to meet objections as they cropped up—to pay wages immediately work was done, to alter the position of a pole if it was not exactly to the taste of the aboriginal owner of the ground, and generally to keep everybody in good temper, so that the work might not stop, for if it stopped a second start might not be easily made.

When the work was all done, the plan pursued bore good fruit, for every Maori through the country who had worked upon the line looked upon it as a piece of his own ingenuity, over which it was incumbent on him to keep a watchful eye.

These scratch gangs picked up all over the country were only permitted to erect the poles and to dig up the ground to a radius of 12 feet around them, as a protection from fire. The wiring throughout was done by one party of Europeans under an experienced wireman, who came steadily on at the rear of all the other parties and finished up, leaving a completed line behind them. By the plans adopted, and which I have endeavoured to describe, the constructor had the satisfaction of finding his line completed and open for traffic on the 11th of March, less than twelve months from the date he returned from his first examination of the country.

The total length of line was 220 miles.

Total cost . . . £18,258 18s. 2d.

Cost per mile . . . £82 15s. 4d.

Of the cost nearly £25 per mile was due to the forest-clearing, which was an exceptionally heavy work.

Of all those engaged upon the work, the constructor and his interpreter led the hardest lives. During the twelve months from the commencement of the line till its completion, they continued travelling on horseback from end to end of the line. They were never more than three or four consecutive days in any one place, but rode about the country day after day without regard to weather all the year through. This was a necessity, for by the constructor's

plans the work was proceeding simultaneously all over the country, and he had to superintend every detail of it, to make all contracts, pay wages, and all other disbursements connected with the line; to issue all instructions to contractors, to negotiate with Maories, and to keep a system of accounts to the satisfaction of the audit department. Of the £18,000 expended during the year the constructor paid (by cheques, for various amounts, from £1 to £1,000) all—except the cost of the wire, arms, and insulators, &c., imported from England. He could not have clerical assistance, for his payments were made, contracts drawn up, and instructions written, under all kinds of conditions. Sometimes his saddle was his writing-desk; sometimes a fallen log served as both chair and table, and often he could not do better than lie face downwards in a Maori hut, and use the floor for a writing-table. He carried writing materials, voucher forms, and a cheque-book constantly on the saddle, and had to be ready to give a contractor a progress payment, pay wages, or draw contracts whenever and wherever the occasion required, without reference to the comfort or convenience of the circumstances surrounding him. The labour and strain upon him were severe and constant from beginning to end, but he had his reward when he saw a difficult work brought to a successful issue.

ABSTRACTS AND EXTRACTS.

THE IMPORTANCE OF A GENERAL SYSTEM OF SIMULTANEOUS OBSERVATIONS OF ATMOSPHERIC ELECTRICITY.

By W. E. AYRTON and JOHN PERRY, Professors in the Imperial
College of Engineering, Tôkiô, Japan.

Read before the Asiatic Society of Japan on the 25th April, 1877.

The great practical value of simultaneous meteorological observations is the assistance they afford us in enabling fairly accurate predictions of the weather to be made some hours in advance. It is unnecessary for us to enter fully into what is being done, and what has been done, in this direction. The weather maps that are issued three times a day by the United States War Department accompanied by, 1st, the table of records of observations, 2nd, the synopsis of these reports, 3rd, the table of probable rain and wind, 4th, the list of facts verifying or disproving the probabilities issued with the previous map, are evidences of the great labour that is bestowed on meteorology by the United States Signal Office, and of the great utility of this work.

But all these observations are derived from instruments like the barometer, thermometer, &c., which are only affected by the air or other bodies in their immediate neighbourhood. A disturbance produced in the higher regions of the atmosphere cannot possibly affect a barometer or thermometer until this wave of disturbance has tarvelled down to the lower air strata, whereas electrical and magnetic instruments are instantaneously sensitive to disturbances produced at great distances: the Pneumatic Despatch and the Electric Telegraph may, in their difference of speeds, be taken as fairly analogous with the sluggish barometer and the ever watchful electrometer. Now, Dr. Veeder has this evening pointed out to us

what great effects on the weather are produced by such disturbances in the higher regions, and why, therefore, in consequence the United States Government observers are specially instructed to observe, and record, the motion of the clouds in the *upper* regions. These instructions, however, they, of course, are utterly unable to carry out when the lower regions are also cloudy. Dr. Veeder has also drawn our attention forcibly to the fact that even surface winds, although they affect the weather, produce no changes in the barometer.

Now, since the value of all storm warnings increases with the time by which they precede the danger, the day may come when electrical and magnetic observations may not only aid, but actually supplant, barometric observations.

But, if an electrometer arranged to measure atmospheric electricity be always varying in its indications, then it may be objected at the outset that we cannot make any use of such observations, for where are the laws which connect wind and rain with the electric potential of the atmosphere? As well, however, fifty years ago might it have been objected that, as storms were very complicated phenomena, and as their connection with atmospheric pressure, temperature, &c., was very vague, it was quite idle to make systematic meteorological observations. Had such objections, however, been allowed to carry weight then, the regular reports of the United States Signal Office, and of other similar offices (which reports, we think, we are right in regarding as among the triumphs of modern science), would have had no existence. But we may go even further than this. Not only has experience hitherto always shown the wisdom of making regular observations, even when their practical value could hardly have been foreseen, but in the case of atmospheric electricity, or rather in the case of its allied subject, natural currents in telegraph lines, one of our greatest meteorologists, the late Admiral Fitzroy, has testified to their value in his forecasts of the weather. Mr. Cromwell Varley, the well-known electrician, having noticed that on several occasions earth-currents were followed by a change of weather, communicated this fact to Admiral Fitzroy, who found such information of so much assistance to him in predicting the coming of storms, that he requested to

have it regularly supplied. "On some occasions," says Mr. Varley, "Admiral Fitzroy could see the approach of a storm days before the barometer or thermometer indicated anything of the kind."

As the time has now arrived when it appears to us to be becoming the duty of all civilised peoples to co-operate in a general system of simultaneous observations of atmospheric electricity, it may be well to consider—first, what observations have been made, and what has been learnt from them; secondly, what is the proper way to make such observations.

Our present knowledge of this subject may be summed up nearly in the words of Sir William Thomson in his address as President to the Society of Telegraph Engineers. Suppose for a moment that there were no electricity whatever in the air—that the air was absolutely devoid of all electric manifestation, and that a charge of electricity were given to the whole earth. For this no great amount would be necessary. Such amounts as we deal with in our great submarine cables would, if given to the earth as a whole, produce a very considerable electrification of its whole surface. We know the comparison between the electro-static capacity of one of the Atlantic cables, with the water round its gutta-percha for outer coating, and the earth, with air and infinite space, for its outer coating. For, since the earth's radius is about 630 million centimetres, its capacity is about 630 micro-farads, or about that of 1,600 miles of cable. Well now, if all space were non-conducting, and experiments on vacuum tubes seem rather to support the possibility of that being the correct view—if all space were non-conducting, our atmosphere being a non-conductor, and the rarer and rarer air above us being a non-conductor, and the so-called vacuous space, or the interplanetary space beyond that (which we cannot admit to be really vacuous), being a non-conductor also, then a charge could be given to the earth as a whole, if there were the other body to come and go away again, just as a charge could be given to a pithball-electrified in the air of this room. Then, I say, all the phenomena brought to light by atmospheric electrometers, which we observe on a fine day, would be observed just as they are. The ordinary observations on atmospheric electricity are precisely the same as if the earth were electrified negatively and

the air had no electricity in it whatever. In rainy weather, however, the potential of the atmosphere referred to that of the earth is sometimes positive and sometimes negative.

Observations made everywhere in the northern hemisphere tend to show that the potential is greater in summer than in winter, but the months of maxima and minima appear to differ at different places. Observations made at Kew and at Windsor in Nova Scotia show distinctly two maxima in the year, those at Brussels and Kreuznach only one. Both the Kew and Brussels observations show in addition two maxima daily at 8 a.m. and 10 p.m. in July, at 10 a.m. and 7 p.m. in January, and at about 9 a.m. and 9 p.m. in the spring and autumn. Although, therefore, all the tests made at different parts of the earth's surface in fair weather (except some of doubtful meaning made at the Peak of Teneriffe in the early days of the study of this question) have shown the earth's surface to be negatively electrified, the amounts of the electricity existing at the same time at different places will be very different; and this difference manifests itself in a manner often extremely disagreeable to the Telegraph Engineer—in natural line currents.

The country in which these natural line currents have been most carefully studied is undoubtedly British India, since the uniform system of land-line testing employed in the Government telegraphs throughout that country causes the accurate measurement of these currents to be daily carried out. From the results of 10,000 such measurements it is seen that in India the direction of the current is far more constant than its magnitude, and on the whole there appears to be a marked preponderance of currents of positive electricity flowing from the east to the west, that is with the sun; and such a current the laws of electro-magnetism tell us would be consistent with the earth's magnetism.

Observations made on the Atlantic cables tend to show that when there are no unusual disturbances the earth currents at one end have two positive maxima and two negative maxima daily. Submarine cables, however, even when long, are far less disturbed by terrestrial currents than land-lines, which may possibly be due to the sea having a far greater electric conductivity than the land.

Since the early days of telegraphy a large number of observa-

tions of natural currents have been made at the principal London office in Telegraph Street, the results of which were communicated to the Astronomer Royal. These tests seemed to show that natural currents in land-lines were the continuations of the submarine currents which were arrested by the comparative non-conductivity of the land, for on Mr. Varley's endeavouring to find the neutral, or equipotential line, for the currents on the east coast of England, he found it to coincide approximately with the shore-line.

Attempts have been made by private people to observe terrestrial currents on short telegraph lines of a few hundred yards which they have erected for this purpose. All such efforts however have been comparatively useless, for the following reasons:—The copper *earth-plates* which are buried at the two ends of a telegraph line, will, on account of their slightly different electric state, depending on the amount of moisture, oxidation, &c., almost invariably produce a current. This current on a long telegraph line will be insignificant compared with the current due to atmospheric causes, but on a short line it will often completely overcome, and mask, the latter. For observatories, therefore, an experimental line should be at least 6 or 7 miles long, and two such should be erected at right angles to one another, so that an idea of the true direction of the current may be formed. Long telegraph lines, however, may even be expected to give better results when a proper instrument, such as will be described further on, is employed for the systematic registration of the natural currents.

During auroras these currents become extremely strong, sometimes as great as can be produced by the employment of a battery of 2,000 Daniells cells, and occasionally even exceeding this. Of such currents the most extensive set of simultaneous observations that have been made was during the remarkable aurora of February 4th, 1872; but as on that occasion these observations were not the result of any general system of measurement, but owed their origin to the fact that the currents became so strong as to interfere with the working of all the telegraph lines throughout the world, it cannot be expected that any large amount of information can be derived from the mass of records made on that day. At first sight it might be presumed that the times at which the strong currents

made their appearance on the different lines would determine the rate at which the phenomena propagated itself over the earth's surface, but if it be remembered that the delicate instruments employed at observatories would be affected long before those used in land-line telegraph offices, and that the receiving instruments used on submarine cables, although much more sensitive than the land-line instruments, are by Mr. Varley's plan of using condensers so arranged as to be extremely little affected by natural currents, it will be seen that the recorded time of these appearances of the strong currents on the different lines is useless for scientific purposes; also it must not be forgotten, that, as the stoppage of a telegraph line represents so much loss of money, the signallers at the commencement of imperfect writing are all busily engaged in attempting to restore communication and have no time for making scientific entries in note books. One point, however, can be learnt from the observations made on February 4th, 1872, and that is this: First, the general direction of the positive currents was from east to west, that is, with the sun. Secondly, along lines running north and south the currents were comparatively weak.

It is well known that auroras are accompanied by magnetic disturbances, and, as Sir E. Sabine has pointed out, the years of maximum sun-spots are those of greatest disturbances in terrestrial magnetism; we may therefore conjecture that atmospheric electricity and sun-spots will be found connected.

There seems to be no doubt now that earthquakes are preceded, or accompanied by, unusually strong natural currents in telegraph lines. As far as we are aware, attention was first drawn to this by one of the writers of this paper in a communication made to the Asiatic Society of Bengal, in June 1871, in connection with the Indian earthquake of February 16th of that year. The Indian earthquake again of December 15th, 1872, was preceded by such strong earth-currents during the evening of December 14th in the land-lines from Valentia to London, that in order to send messages it was necessary to loop the lines, by means of which the current in the one line was made to neutralise that in the other. The Egyptian earthquake of January 12th, 1873, was preceded for some days by equally strong natural currents. This earthquake

was also accompanied by an eruption of the volcano Shaptar Jokull in Iceland, which lasted from January 9th to January 12th, and it is interesting to notice, as Mr. Graves of the Atlantic Cable Company has pointed out, that a direct line drawn from Cairo to Iceland crosses the telegraph wires from Valentia to London. Again, the Italian earthquake of March 17th, 1875, was accompanied by great disturbances on the land-lines of Italy. One case published by Mr. Varley in 1873, of a momentary current observed by him in 1864 in a cable coiled up in a tank, simultaneously with a slight earthquake shock in England, must, of course, not be included in the above list, as here the momentary current was produced by the actual tilting of the cable tank and not by a great difference between the earth's potential at two remote places. Such a current as that observed by Mr. Varley is generally noticed during the laying of a submarine cable each time the ship pitches, in consequence of the cable being thus moved backwards and forwards across the earth's magnetic lines of force. When the systematic testing of natural currents is introduced into the Japanese telegraphs, and this, judging from the progress made in that department during the last few years, we hope to see at no very distant date, then the scientific world may expect to receive such a fund of information on the connection of these currents with earthquakes as will remove this subject from the realms of conjecture and place it in the region of certainty.

In what has preceded we have briefly indicated our reasons for concluding with a fair amount of certainty that (1) atmospheric electricity, (2) auroras, (3) earthquakes, (4) magnetic distances, (5) natural currents in telegraphic lines, (6) sun-spots, and (7) wind-storms, all are linked together, and we feel that if this is shown nothing more is needed to induce thinking people to interest themselves in the subject of this paper.

As regards the methods of measuring the atmospheric potential we have not much to add. Sir William Thomson's quadrant electrometer, combined with his water-dropping collector, forms a very delicate measuring apparatus for observatories, and can easily be made self-recording; his portable electrometer and burning match may be used instead by travellers, or when neither very delicate

observations nor automatic records can be taken. Full instructions for the use of this latter instrument were supplied in the manual furnished to the officers who accompanied the late Arctic expedition, and can be obtained by any one desiring to use the instrument.

Concerning natural line currents a mass of information could be collected if telegraph operators everywhere would, when no messages were being sent or received, make frequent observations of a moderately high resistance tangent galvanometer placed between the line and the ordinary receiving instrument, or between the receiving instrument and the earth-plate. Although this would entail but very little extra work on the signallers, it is possible, nevertheless, that considerable difficulty might be experienced in inducing private Telegraph Companies to issue rules giving such duties to their employés. Government administrations, however, might, in view of the very important information to be gained, be prevailed upon to issue such regulations, and it is the duty of scientific men to urge the matter. But better results would probably in all cases be obtained if the Royal Society, the British Association, and other similar scientific societies, would furnish telegraph offices with self-recording instruments, guaranteeing, of course, that their use would not interfere with the ordinary working of the telegraph line. Such an instrument might be cheaply made, and we would suggest the following as a possible form:—Between the telegraph line and the receiving instrument let there be inserted, on every line in all important offices, a long wire forming a coil about 15 centimetres internal diameter with its plane parallel to the magnetic meridian. Turning on a pivot fixed at the centre of this coil is a thick short magnet about 2 centimetres long, or a system of magnets, carrying a brass disc about 12 centimetres in diameter, and of such thickness that the time of oscillation is about 5 seconds. A strip of photographic sensitized paper, such that it requires about 5 minutes to be decidedly blackened under such diffused light, whether sunlight or lamplight, as may be available, and about 12 centimetres broad, is moved along underneath and parallel to the disc at the rate about 10 centimetres per hour, and so that the centre line of the paper passes

under the centre of the brass disc. A round hole 2 millimetres in diameter, with bevelled edges near the circumference of the disc, allows diffused light to blacken a small portion of the sensitized paper. The magnitude of the steady natural current will, therefore, be always registered, while rapid variations of the current produced by the signalling will have no effect in consequence of the large moment of inertia of the disc. The rollers on which the paper is wound might be moved by a very simple clock going, say, 15 hours, but which would be regularly wound up every morning and evening, at which time the signaller would make a pencil-mark on the paper. These marks would be of great assistance in measuring time along the paper when it was examined, and would also check any great irregularity in the going of the roller clock. The sensitized paper ready wound on the rollers would be supplied in closed-in tin boxes, each box containing sufficient paper for one month's use. The box would be put in position underneath the disc, the projecting axle of the roller being connected with the clock by means of a catch, and a sliding tightly-fitting door opened in the top of the box to allow the light which passes through the hole in the galvanometer disc to fall on the paper. At the end of the month the slide would be closed and the box returned to the person who had charge of the investigation, who would then fix the photograph, and refill the roller with fresh paper. Removing one box from underneath the galvanometer and substituting another would not, of course, stop the working of the line, even for a second, since the line and galvanometer connections are not interfered with.

It might be objected that not only would sudden changes in the current produced by signalling leave no record on the paper, but sudden variations in the natural current would also pass by unrecorded; undoubtedly, if the changes in the natural currents were comparable with the making and breaking of the signalling current both as regards rate and intensity of change, this would be the case, and it is difficult to see how any instrument could be devised in which it would be otherwise. But this objection is not a serious one, since such sudden changes are only produced during a magnetic storm, and it is not from such observations that much infor-

mation can (at any rate at the commencement of the study of the subject) be gained.

We have not in this short paper referred to the medical value of systematic observations of atmospheric electricity, but we are informed by well-known doctors, that they believe the electric state of the air has no small effect on the general health of the public.

[It may be well to remark that any suitable *simple* recording arrangement would be exceedingly valuable if applied to a Thomson's improved ship's-compass. Such an arrangement, working, say, in the captain's cabin, would give a complete record of the course of the ship during a voyage.]

A DUPLEX PARTIAL-EARTH TEST.

By W. E. AYRTON and JOHN PERRY,

Professors in the Imperial College of Engineering, Tôkiô, Japan.

All practical Electricians are aware of the great difficulty experienced in determining the exact position of a partial earth fault when the loop test cannot be employed. The well-known method devised by M. Blavier (see Clark and Sabine's *Electrical Tables*, p. 47), which consists in making two tests of the resistance of the faulty line—the one when the distant end of the line is insulated, the other when it is put to earth—has the very serious objection that unless the resistance and polarisation of the fault remain constant while the two tests are being performed no use can be made of the tests. Now, apart from circumstances unconnected with the testing, the resistance and polarisation of the fault are extremely likely to vary: first, because the current passing through the fault in the insulation test is much greater than in the conduction test, and this is especially the case when the fault is near the distant end of the line; secondly, because, if any electromotive force exists in the fault, then tests with reverse currents must be made, both when finding the insulation and conduction resistances, and reversing the

current is almost certain to alter the resistance as well as the electromotive force of the fault.

To overcome the objection to combining conduction and insulation tests it has been proposed, when a second wire is available for speaking, but which is not sufficiently well insulated to be used in a loop test, to make *successively* insulation, or conduction, tests from the two ends of the line, and from each pair of tests, to calculate the distance of the fault in the well-known way (see Clark and Sabine's *Electrical Tables*, p. 48). Messrs. Latimer Clark, Lumsden, and others, have also proposed methods, to be used, in this and similar tests, for depolarising the fault by reverse currents being applied in special ways (see *Culley's Practical Telegraphy*, pp. 315-320).

All these methods however have the objection that unless the resistance of the fault be nought two tests must be taken *in succession*, and these can only be made use of if the resistance and polarisation, or non-polarisation, of the fault remain quite constant during testing.

Plans can of course be devised of overcoming these difficulties if instruments for measuring differences of electric potential (electrometers or condensers combined with high-resistance reflecting galvanometers) are available at the two ends of the line (see Clark and Sabine's *Electrical Tables*, p. 50). But although such instruments exist in submarine cable stations they are never met with in land-line telegraph offices: consequently some method of testing is desirable which requires the employment of only the ordinary galvanometers such as are commonly used with Wheatstone's bridges.

Two methods of *simultaneous* testing at both ends of the line, with ordinary galvanometers only, have suggested themselves to us, by means of which the position of a partial earth-fault can be accurately determined. Of these plans the following one is the better, and although simple has not, as far as we can learn, been hitherto published or employed. It has the two great advantages that—

1. It is independent of changes of resistance of the fault;
2. It is independent of any electromotive force in the fault.

FIRST.—Connect two galvanometers and batteries to the faulty line, one set at each end, as shown in fig. 1. One of these batteries has its copper pole to line, the other its copper pole to earth; this

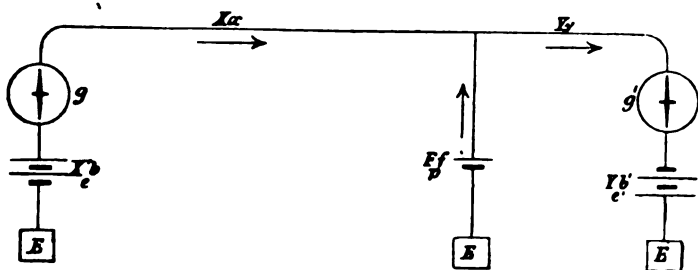

Fig. 1.

is for the purpose of sending as little current as possible through the fault so as not to alter its resistance or polarisation with too great rapidity. This precaution is desirable but not indispensable. Note the current on the galvanometer at each end at the moment when a signal is sent on a second line (which is workable but not sufficiently well insulated to be used in the loop test), or, better, adjust the controlling magnet of the galvanometer at each end so as to keep the needle at zero,* and at the moment a signal is given on the second line leave the magnet alone; the latter method of keeping the needle at zero has the advantage that the galvanometer is then used in its most sensitive state.

SECOND.—Disconnect the galvanometers from the line and insert resistances r and r' as in fig. 2, so as to exactly reproduce the currents previously obtained, or so as to exactly bring the needles back to zero, the controlling magnets being left as they were the moment the signal was sent on the second line. Attach one pole of a Latimer Clark's constant cell (these are very cheaply made, and have an extremely constant electromotive force if they are not employed in sending currents) to some point A, A' of the resistance coils, and find another point B, B' such that no current passes through the battery detector d, d' when it and the cell are connected with the points A B, A' B', care being taken to send as few currents

* This adjustment should be made by turning the magnetic field of force without producing much alteration in its strength.

as possible through the constant cell during the trial. Let the resistance $A B$, $A' B'$ be q q' respectively.

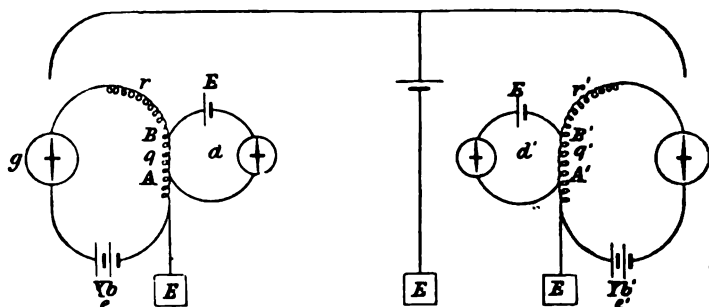

Fig. 2.

Let x , y be the resistances of the line from each end up to the fault, and l the resistance of the whole line, previously obtained by testing when no fault existed, then

$$x = \frac{q' r + q (r' - l)}{q' - q}$$

$$y = \frac{q' (l - r) - q r'}{q' - q},$$

as will now be proved.

Let e e' be the electromotive forces of the batteries, and X , Y the currents flowing through the two portions of the line, then by Kirchoff's second law we have from the first test made *simultaneously* at the two ends of the line

$$X(x + g + b) + Y(y + g' + b') = e + e'.$$

The fault may have a resistance f , an electromotive force p , and there may be a current F flowing through it, but the above equation contains none of these three unknown quantities.

From the second test, we find by Ohm's law, if E is the electromotive force of the Clark's constant cell,

$$X = \frac{e}{r + g + b}$$

$$Y = \frac{e'}{r' + g' + b'}$$

$$\frac{e}{E} = \frac{r + g + b}{q},$$

$$\frac{e'}{E} = \frac{r' + g' + b'}{q'}$$

therefore, eliminating X, Y, e, e' , we have

$$\frac{x-r}{q} = \frac{r'-y}{q'}$$

But

$$y = l - x$$

$$\therefore (q' - q)x = q'r + qr' - ql$$

$$\text{or } x = \frac{q'r + q(r' - l)}{q' - q}$$

$$\text{and } y = \frac{q'(l - r) - qr'}{q' - q}$$

When instruments for measuring differences of electric potential are not available, as for example in offices connected with cables under rivers, under straits, &c., then this method will be found of great value for determining the position of a partial-earth in a submarine cable, since if *simultaneous* readings or adjustments of the galvanometers be made at *fixed times* previously agreed upon, and the results communicated afterwards by ship, no second cable is necessary.

JOURNAL

OF THE

SOCIETY OF TELEGRAPH ENGINEERS.

VOL. VI.

1877.

No. 19.

The Fifty-eighth Ordinary General Meeting was held on Wednesday, the 25th April, 1877, Mr. LATIMER CLARK, C.E., Past President, in the Chair.

The following paper was read :—

ON BATTERIES.

BY MARTIN F. ROBERTS, F.C.S.

Batteries are of such extreme importance to all Telegraph Engineers, and the cost of their construction and maintenance forms such a very considerable item in the working expenses of, I may say, almost every line of telegraphs, that I trust the paper I have the honour of reading this evening will not be altogether without interest, and I even hope that it may be of some practical value to the members of this Society. I have not attempted to discuss in this paper the relative merits of the many batteries now in use for telegraph purposes, as this question has been recently so ably dealt with by Mr. Sivewright in the paper he read before this Society on "Batteries and their Employment in Telegraphy," but I have rather confined myself to giving the results of experiments I have made with a view to obtaining the best possible working from the two batteries most largely used in this country, viz., the Daniell's and Leclanché; and in stating these results I have purposely, as far as possible, avoided purely theoretical questions, although I

regret to say that many points which deserve a very important place in any paper of this description have been omitted.

It will be convenient, I think, if I first refer to the porous cell, which is one of the principal features of the usual forms of the batteries I have named, as it not only largely affects their life and working, but is the cause of considerable trouble when an attempt is made to fit up equal cells, either for the purpose of comparison or for testing. One of the most, if not the most, important points to consider is, of course, its resistance, but this cannot be measured by immersing the cell in an electrolyte, and sending a current through it from a battery, owing to the polarization caused by the decomposition of the liquid, for even if a very feeble current is used, and an endeavour made to get a very quick reading, really satisfactory and reliable results cannot be obtained. Another method I have tried is to rapidly reverse the current by means of a whippe, but this way is inconvenient, especially when a large number of cells has to be tested, and is not, I think, nearly as suitable as the following method:—A square glass or ebonite cell is fitted up in the Daniell's form, when the cells to be tested are intended for use in that battery, the zinc plate being placed in a porous pot containing a solution of sulphate of zinc, and the outer cell being filled with a solution of sulphate of copper of known strength, the copper plate being held in position by passing through a strip of wood or ebonite, fixed at the top of the cell, thus:—

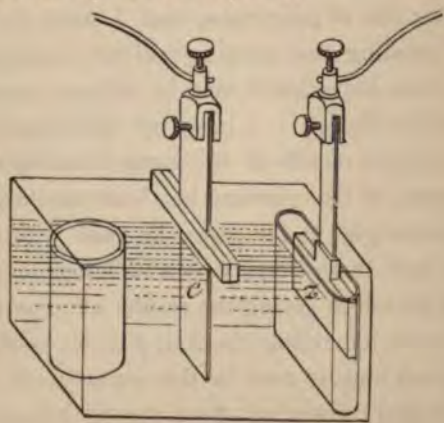

Fig. 1.

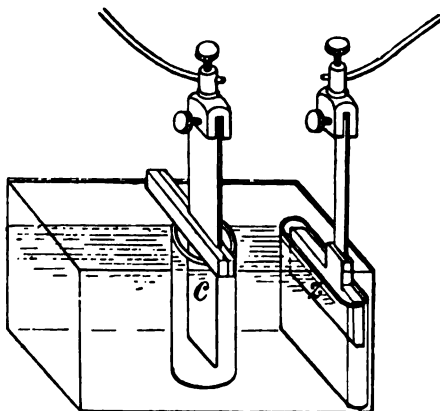

Fig 2.

The internal resistance of this cell is then measured, either by joining it up in circuit with a tangent galvanometer, and adding resistance until we get half the deflection, or by Sir William Thomson's, or one of the other methods commonly in use. The porous cell to be tested, which has been filled with, and placed in, a solution of sulphate of copper of the same strength as that used in the battery, during, say, the previous twenty-four hours, is then removed to the cell of known resistance, and placed so that it surrounds the copper plate. On again measuring the resistance of our cell, which now includes two porous pots, the increase will be due to the one surrounding the copper plate, and it is therefore only necessary to deduct the figures obtained in our first from those obtained in our second experiment to get the true resistance of the porous cell we are testing.

A round cell 4 inches high by $2\frac{1}{2}$ inches in diameter, and $\frac{1}{8}$ th of an inch thick, after being soaked in a saturated solution at 60° F. of sulphate of copper for twenty-four hours, should not give more than 2 ohms resistance, and this resistance will usually decrease to a considerable extent after the cell has been in use a few days.

To measure the resistance of cells in a solution of chloride of ammonium (sal-ammoniac) the arrangement would be the same,

except that a zinc plate is placed in the cell to be measured in place of the copper one used in the arrangement already described, and, instead of the porous cell containing sulphate of zinc, a cell fitted with a carbon rod, and packed with powdered carbon and manganese, is employed. A cell $4'' \times 2\frac{1}{2}'' \times \frac{1}{8}''$ thick, measured in a saturated solution of sal-ammoniac at 60° F., should not exceed $1\frac{1}{2}$ ohm.

Of course, to measure a cell in dilute sulphuric acid, it is only necessary to use a Grove's arrangement, placing the zinc in the cell to be measured; and, to determine the resistance in nitric acid, the same form of battery can be used, the platinum plate, however, being this time placed in the cell to be measured.

Suitable porous cells having been obtained, the most important consideration when fitting up a Daniell's battery is the purity of the zinc used for making the plates, as mercury cannot be used with advantage for amalgamating them, owing to its forming an amalgam with the copper which is always more or less deposited on the zinc plate in this battery. The average composition of the zinc used by the Post Office during the last two years has been about

99.38	per cent.	zinc
0.50	,,	lead
0.12	,,	iron,

with usually scarcely any trace of copper, arsenic, or sulphur, although it is not at all an unusual thing to get samples of so-called pure zinc, from firms who do not understand our requirements, containing as much as 2 or 3 per cent. of lead. The figures I have given show a very high quality of zinc, which we have now no difficulty in obtaining, although some years ago we had very considerable trouble in getting spelter which contained less than 1 per cent. of lead, and many large deliveries were rejected on this account. This improvement in quality is, I think, as much due to the fact that manufacturers know that each parcel is tested before approval, as to any superior process of refining this metal which may now have been adopted, and, I think, shows the necessity for all materials of this description being analysed before use, as it is only by these means that it can be determined if a delivery is suitable for battery requirements or not; for no proof is required to show the inaccuracy of a statement which is sometimes made, that

a high quality of spelter can be recognised by its crystalline appearance when broken, and the idea indulged in by many battery men, that the crystals of pure sulphate of copper should be perfectly transparent, is equally fallacious.

A most important point when purchasing sulphate of copper is the quantity of water the crystals contain, as it is not an unusual occurrence for parcels of this substance to contain quite 3 per cent. of extraneous water. The quantity of water which crystalline sulphate of copper contains can be readily determined by those who do not possess much skill in chemical manipulation, as it is only necessary to keep a weighed quantity of the sample to be tested (say about 25 grains) at a temperature of from 212° to 230° F. until it ceases to lose weight, to find the quantity of extraneous water, together with the quantity of water of crystallization it contains. Now as sulphate of copper contains 28.9 per cent. water of crystallization, whatever loss there is greater than this quantity is due to excessive moisture, but the commercial article rarely contains less than 1 per cent. of extraneous water. In this experiment care must be taken not to raise the temperature above 230° F. or the sample will lose some of its water of constitution, which would make the results obtained inaccurate. The importance of using sulphate of copper almost free from iron has, I am inclined to think, been greatly exaggerated, and I shall be glad of any information which Members who have had greater experience than I have had can give me of cases where bad results have been obtained from cells owing to the sulphate of copper with which they were charged containing a large quantity of sulphate of iron. It is stated in several standard works on telegraphy that this material should not contain more than a mere trace of iron; but I have fitted up cells with sulphate of copper which contained as much as 0.7 per cent. of crystalline sulphate of iron (green vitriol), and find that the electromotive force and quantity are not reduced, and the consumption of sulphate of copper, so far as I have been able to determine, is not more rapid, nor is the internal resistance of the battery materially increased.

One of the principal causes of defective working in this battery, and one which has certainly not received the attention which its

importance demands, is the action of hard water with which it is frequently charged. It is a well-known fact that well and river waters usually contain several of the following substances: viz. carbonates of calcium, magnesium, and iron; sulphates of calcium, magnesium, sodium, potassium, and aluminium; chloride of sodium, potassium, and calcium; silica, phosphate of calcium, carbonic, hydrosulphuric, and nitric acids, and, in very small quantities, bromides, iodides, &c. Of these substances the telegraph engineer has, except in rare cases, only to contend with carbonate of calcium and carbonic acid, sulphate of calcium, sulphate of magnesium, chloride and sulphate of sodium, and, in a few localities, hydrosulphuric acid and chalybeate waters. I have lately ascertained, as accurately as possible, the effect of most of these last-named substances on the working of a Daniell's and Leclanché battery, and my experiments conclusively prove that the Leclanché has a decided advantage over the Daniell's, in that it is scarcely affected by the quantity of calcium and magnesium salts usually met with in hard water.

The average increase in resistance in a Daniell's cell if charged with water containing 50 grains of carbonate of calcium to the gallon (that is, water of 50 degrees of temporary hardness,) is 28 per cent., and there is a corresponding falling off in quantity; the electromotive force also falls off about 5 per cent. The bad working caused by carbonate of calcium can, however, be considerably reduced by adding a small quantity of dilute sulphuric acid to the battery, but care must be taken when wooden troughs coated with marine glue are used, that strong acid has been diluted with at least four or five times its weight of water, otherwise the heat evolved will be likely to sufficiently soften the glue to permanently damage the battery. A better plan than using sulphuric acid is to boil the water before use so as to expel the carbonic acid it contains, when the carbonate of calcium will be deposited owing to its being almost insoluble in water free from carbonic acid. Water which has been heated for domestic or other purposes may, therefore, be advantageously used. It is, however, preferable for a battery-man when he finds that the liquid in the porous cell containing the sulphate of copper becomes cloudy, and a thick scum

forms on it, indicating usually the presence of carbonates or carbonic acid, to make an endeavour to get rain-water, as he is then pretty sure to get good working batteries without further trouble.

Sulphate of calcium, usually the principal cause of what is called permanent hardness, although as we should expect not nearly so injurious as the carbonate, causes 10 per cent. increase in the resistance, and, consequently, a similar falling off in the quantity when water of 50 degrees of hardness as before is used—that is, water containing 68 grains of sulphate of calcium to the gallon; but the electromotive force, if there is any decrease at all, does not fall off more than 2 per cent.

A small quantity of chloride of sodium (common salt) in the water used in a Daniell's battery also causes no appreciable difference in the electromotive force, but $58\frac{1}{2}$ grains to the gallon, that is, a quantity of sodium equivalent to the quantity of calcium used in the previous experiments, increases the internal resistance of the cell about 9 per cent. and therefore decreases the quantity, but these results appear rather anomalous, as we should at first sight expect the chloride of sodium rather to increase than otherwise the conductivity of the liquids in the cell. The cause of the higher resistance is, however, soon discovered when the battery comes to be examined, as it is found in most cases that the deposit of electrotype copper instead of taking place equally all over the copper plate forms in patches, and that frequently half or even three-fourths of the surface of the plate is rendered useless, probably owing to the formation of a thin coating of chloride of copper when the battery is not working. Chloride of sodium also causes a thick scum on the liquid in the battery after it has been working a short time, somewhat similar to that caused by carbonate of calcium, except that it does not produce any clouded appearance in the solution in the copper cell.

Sulphate of magnesium, when water containing not more than 60 grains to the gallon is used, a quantity of magnesium again equivalent to the quantity of calcium used in the first experiment, does not, so far as I can say, in any way affect the working of a battery or cause any dirty appearance.

I have already referred to the damage which may be done to a marine-glue-coated trough through the use of concentrated sulphuric acid, and I would point out a curious instance of this in the trough on the table. It will be noticed that in some places on the bottom of the trough small round holes have formed in the marine glue, and, as this defect was found in several batteries, we were very much puzzled as to the cause when it was first observed. It was, however, found, when the history of these batteries was inquired into, that they had usually been employed at race meetings, and it was eventually discovered by Mr. W. H. Preece that sulphuric acid had been used to enliven them up. Of course it was then at once seen that the high specific gravity of the sulphuric acid had caused it to fall to the bottom of the cell, and the heat produced by its combining with the water had been sufficient to, in some cases, cause the holes to which I have referred, and in others to melt the glue, so that it was all found floating at the top of the cells.

The Leclanché cell, although at first sight it would appear far simpler in construction than the Daniell's, is much more complicated when we come to consider its chemical action and the various points which require attention to insure good working. Its advantages, when compared with the Daniell's, are, that it is charged with only one liquid; that it requires less attention; that there is but little waste when it is not working; that the materials used to maintain it are not costly; that hard water does not affect its working; and that it gives about 75 per cent. more electromotive force when first put in action and considerably more quantity and less internal resistance. Its disadvantages are, that it is not constant; that it is impossible to prevent the porous cells splitting or cracking, if it is hard worked, through a low resistance; and that great care has to be taken in its construction to prevent many causes of bad working to which its present form renders it liable.

Of course, as this cell has been patented, only the manufacturers appointed by the patentee (the Indiarubber and Guttapercha Company in this country) are at liberty to make it, but the following points require attention when replacing those portions of it which have become useless. The manganese used should be of the crystalline variety, and should contain not less than 85 per cent. or at

the lowest 80 per cent. of pure peroxide. This, like sulphate of copper, is another substance which should always be analysed before use, as some of the samples I have had sent me for analysis during the last few years, and which have been represented as of high quality, have not contained more than 35 per cent. of peroxide, and would therefore have been of no use for fitting up this battery.

The next important consideration is the resistance of the carbon plates, and it is very advisable that every one should be tested before use. A convenient way of making contact with the plate is to rest each end on a small flat surface of mercury. The maximum resistance in a carbon plate $4\frac{3}{4}'' \times 1\frac{7}{8}'' \times \frac{5}{16}''$ should be 1 unit, but good plates, made from the carbon of gas retorts, when tested in this way, do not average more than 0.5 unit, and a very large proportion of them come out as low as 0.1 unit, and in some cases even less.

Of course these plates do not give nearly as much resistance when in use in a battery as when tested with the mercury connection, owing to one-half of the plate being immersed in the fluid with which the cell is charged, and the connection made by the lead cap is usually rather better than the one made by the mercury.

It will be remembered that when the Leclanché battery was first brought into use it gave much trouble, owing to the solution of sal-ammoniac rising through the carbon to the lead cap, which it rapidly converted into a chloride of lead, and, as this salt when dry is a bad conductor, in many cases it rendered the cell completely useless. This defect has now been entirely removed by the manufacturer, by soaking the upper portion of the carbon plate, after capping, in melted paraffin wax or tallow mixed with resin, and allowing the plate to cool in it, but the former substance is found to give by far the better results. This operation of soaking the carbons with an insulating material is not found to increase their resistance, as the figures we obtained when experimenting with tallow, and which are given below, will show:—

No.	Res. before Capping.	Res. after Capping the Plain Plate.	No.	Res. before Capping.	Res. after Capping.
1	·19	·17	10	·21	·10
2	·26	·19	11	·36	·28
3	·40	·35	12	·40	·10
4	·38	·35	13	·41	·38
5	·57	·51	14	·53	·51
6	·60	·48	15	·59	·30
7	·80	·74	16	·62	·60
8	·90	·72	17	·80	·73
9	1·10	·60	18	·95	·93
	<hr/>	<hr/>		<hr/>	<hr/>
	5·20	4·11		4·87	3·93
Average	·57	·45		·54	·43

Tallow.

Tallow and
Resin.

I may mention, while speaking of carbon plates, that we find those cut from the carbon obtained from gas retorts very superior to those manufactured by moulding, as the latter average about four times the resistance of the former, and in some cases give as much as 14 to 20 ohms.

You will be aware that the original form of the Leclanché battery consisted of a porous cell containing the carbon plate, surrounded by crushed carbon and peroxide of manganese, inclosed in a glass jar; but, owing to the tendency of the porous cell to split in this battery, frequent experiments have been made with a view to dispense with the porous cell altogether. With this object, the porous pot has been replaced by a bag of felt or canvas, and also by perforated earthenware cells; but my experience leads me to think that neither of these modifications is desirable, as, in addition to the polarization being more rapid, considerably more local action takes place, apparently caused by small particles of manganese or carbon reaching the zinc plate. A far better plan is the gravity arrangement proposed, I think, by Mr. Fuller; but, even in this form, it is advisable to wash the crushed manganese and carbon, to remove any traces of the powder produced when the materials are being broken before use.

The polarization in a gravity cell fitted up as above is, when *short-circuited*, slightly more rapid than when a porous cell is used,

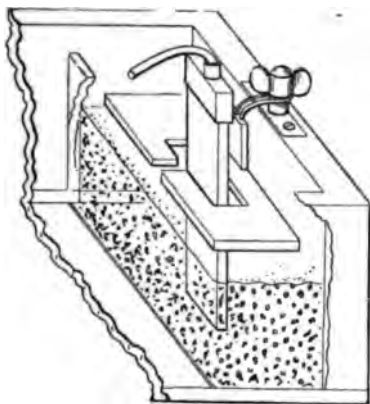

Fig. 3.

but then its recovery is equally quick, so that in actual working the results obtained compare very favourably with the original form of this battery; and the internal resistance is extremely low, not averaging more than $1\frac{1}{2}$ unit.

Another disadvantage in the usual form of the Leclanché battery is the risk of damage which the porous and glass cells run when being conveyed from one place to another, and, to avoid this, about four years ago the Post Office ordered a number of these batteries arranged in a teak trough, with the cells separated by slate partitions, and coated inside with marine glue, in the way that Daniell's elements are now usually fitted up for telegraph purposes. These batteries can scarcely be said to have worked well, as, when they are used on any but very light circuits, the formation of oxychloride of zinc takes place so rapidly, owing to the zinc plate having been made too large for this form of battery, that the porous plate has frequently been known to split and become quite useless in two or three months. When we came to refit these troughs with new porous plates, and reglue them, it was found, on their being tested before they were reissued, that every cell was in contact, and, as it is a very unusual occurrence for us to get any "cell-to-cell" leakage in a refitted Daniell's trough, we at first attributed the failing to the troughs having been damp when glued, or to some carelessness on the part of the men, and another lot was therefore boiled out and glued, but with exactly the same result, every cell being in contact. As we were even then not satisfied that proper care

had been taken, another lot of troughs was refitted, but, as we found them just as bad, it was evident the defect was not caused by careless fitting; and, on a careful examination of the old troughs being made as they came in, it was found that the solution of sal-ammoniac had soaked through the porous plate to the bottom and sides of the wood trough, and then through the end wood from cell to cell. It is a curious fact that, as I have already mentioned, the Daniell's form of battery, when fitted up in a teak trough and coated with marine glue, never, or scarcely ever, has this defect; and, apart from the fact that the trough Leclanché batteries of which I have been speaking were not made of the best quality and closest-grained teak, there is no doubt, from the quantity of sal-ammoniac I found when making an analysis of some of the wood taken from the batteries, that a solution of this salt has far greater penetrating powers than a solution of sulphate of copper. In the next lot of Leclanché batteries we refitted we used porous cells, the edges of which had been glazed with a sealing-wax varnish, thus:—

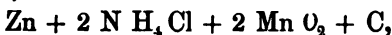

Fig. 4.

At the same time we fitted an equal number of cells in exactly the same way, but with unprepared porous plates; and these experiments at once proved that our theory as to the "cell-to-cell" leakage was correct, for we found that only three of the cells fitted with the prepared plates were in contact, and in these cases it was no doubt due to the sealing-wax having been in places chipped off, while all the cells fitted with the ordinary plates were so bad that we could not use them. These experiments proved the necessity of fitting this form of battery with porous plates with glazed edges, and I have no doubt that, if the Post Office orders another lot of these trough Leclanché batteries, as we call them, they will stipulate that they are to be fitted with plates prepared in this way.

I have already mentioned that the bursting and flaking of the porous cells is one of the greatest defects of the Leclanché form of battery, and, looking at the chemical action which takes place in this cell, I am afraid that, while porous ware is used, this cause of failure will never be entirely removed. You will be aware that the chemical action in this battery is usually represented thus:—

Before contact,



and after contact,

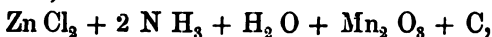

and there is no doubt, the instant the battery is first put in action, that this formula is correct; but, when the chloride of zinc increases in the cell, we must find another formula, as an ammonio-chloride of zinc commences to form, which usually first appears in crystals on the porous cell.

This later action must be represented as

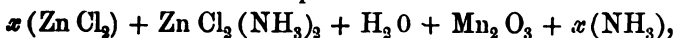

“*x*” in both cases representing an indefinite quantity, as the quantity of liberated ammonia which combines with the chloride of zinc in solution is not constant, and varies with the temperature and the form of the cell, but the composition of the first crystals which appear is $\text{Zn Cl}_2 (\text{NH}_3)_2$. As this battery goes on working without the solution of sal-ammoniac being renewed we even get a third, and, I am disposed to think, frequently a fourth action, but these last reactions are very complicated, and I can therefore only give you an idea of them by the composition of the oxychlorides of zinc which form in the battery. We must remember, to understand these last actions, that as the battery goes on working we get a very concentrated solution of chloride of zinc, and that ammonia is still being produced, and this ammonia, especially when it is formed rapidly by the battery being hard worked, combines with the chloride of zinc under some circumstances, I am inclined to think, in the way represented by the first, and under others in the way represented by the second, of the two following formulæ:

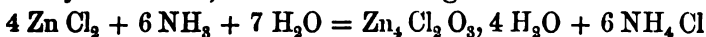

or

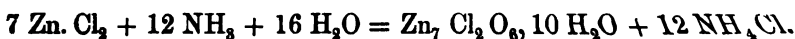

And now that we have so far considered the chemical action in Leclanché's cells we can understand why the porous cells burst, as all the zinc salts which are liable to be formed in this battery, viz. the crystalline compound of ammonia and zinc chloride $(\text{NH}_3)_2 \text{Zn Cl}_2$ and the two oxychlorides $\text{Zn}_4 \text{Cl}_2 \text{O}_3 \cdot 4 \text{ aq}$ and $\text{Zn}_7 \text{Cl}_2 \text{O}_6 \cdot 10 \text{ aq}$, are soluble in a saturated solution of sal-ammoniac, and insoluble in water.

As this battery continues working, the solution of sal-ammoniac gradually becomes less concentrated (owing to the chlorine being taken up by the zinc and the ammonia liberated), and if we could continue the action long enough we should get no sal-ammoniac left in the battery; but long before the battery gets in this state the solution has lost so much of its sal-ammoniac, that is, if it has been hard worked and the sal-ammoniac has not been renewed, that the solution is not concentrated enough to hold the zinc salts in solution, and consequently they crystallize out. The most curious point however which presents itself here is that the chloride of zinc formed in this battery finds its way into the porous cell which surrounds the carbon plate, although in a Daniell's battery we never find that the zinc accumulates in the porous cell until the sulphate of copper has become exhausted. But, without considering by what action it reaches the inside of the porous pot, it is only necessary to admit that it does find its way there, and of this there can be no possible doubt, to fully account for the cells bursting, as the ammonia, as it is formed, converts the chloride of zinc into first one and then another of the salts we have named, which, as they become too concentrated for the already dilute solution to keep them dissolved, crystallize out, expanding in very much the same way that water does when freezing, and with force quite sufficient to account for the porous cells bursting.

The cause of the peeling of the porous cell is exactly the same, except that in the latter case the chloride of zinc and ammonia crystallize out in the pores of the porous ware as well as inside the cell.

It will be seen that the liberated ammonia is the cause of all this trouble, and it is therefore not advisable to seal this battery up *air-tight* when it is required for really hard work, but rather to

give the ammonia every facility for escaping. I may mention that I am not advocating the advisability of using open in preference to sealed cells on theoretical grounds only, as the results of experiments I have made with this battery enable me to state that an open cell works, when constantly in use and through a low resistance, much longer, and gives far better results with the same consumption of sal-ammoniac than if it had been hermetically closed.

The formation of the basic or oxychlorides and ammonio-chlorides of zinc, which I have shown is one of the causes of the ultimate failure of this battery, can be prevented by occasionally adding a small quantity of hydrochloric acid to the liquid in the cells to neutralise the ammonia held in solution, but only sufficient acid should be added to give the liquid a slightly acid reaction. This method of getting rid of the oxychlorides by converting them into chlorides and neutralising the ammonia could not, however, be conveniently adopted in practice.

The method at present in vogue with linemen who see to the maintenance of the batteries, that is, to add more sal-ammoniac whenever the oxychlorides make their appearance, is also anything but economical, and one which has, I am inclined to think, unfortunately got into general use through the following instructions for charging the battery being issued with each 10-cell trough by the Indiarubber and Guttapercha Company. These directions are: "When the liquor becomes thick or milky add sal-ammoniac such as was originally in the glass cell, which will cause it to appear clear in a few hours, and the battery will be as powerful as when first charged."

Now, there are several objections to this practice of adding sal-ammoniac when the oxychlorides commence to crystallize out, and it has not, so far as I am aware, one single advantage. In the first place, as the conducting power of a concentrated solution of sal-ammoniac is better than the solution of, I think I am correct in saying, any other salt, we only increase the resistance of the cell by using a solution of oxychloride of zinc and sal-ammoniac in its place, and, not only this, but the larger the quantity of chloride or oxychloride of zinc contained in the solution the greater tendency

it has to crystallize out, and cause the bursting and flaking of the porous cells to which I have already referred.

It would therefore be far better to instruct those who have charge of these batteries to entirely remove all the liquid they contain, and recharge them with a new lot of sal-ammoniac and water, whenever it is noticed that there is the slightest tendency in the solution in the cells to become milky, and this, too, is by far the more economical plan, for it is obvious, when we come to consider the matter, that no sal-ammoniac is wasted by this method, because whatever quantity remained in the liquid we are throwing away is required to keep the oxychlorides in the solution from crystallizing out, and is therefore able to do no work without causing a larger quantity of the oxychlorides to make their appearance. And not only is the sal-ammoniac in the old solution of no use, but a portion of what we are adding to it is not available for actual work, owing to its being required to dissolve and hold in solution those crystals which have already formed.

There is another way in which the crystals cause the failure of this battery besides bursting the porous pots, and that is by forming a completely air-tight coating about half way up the outer cell, and as soon as this has taken place the ammonia which is liberated as the battery continues working forces all the liquid in the bottom portion of the cell through the porous pot, and out above this crust into the glass cell again; and, if the battery is still kept hard working, a second coating sometimes also forms, from below which all the liquid is again expelled as the free ammonia is liberated by the action of the battery. I have here two cells in which this action has taken place, one of which is still working, and the other has had one side broken open, to show more clearly the way in which this crust forms. In this last-named cell the formation of both the first and second crust is so complete that I think it will be particularly interesting to those gentlemen who have not before observed this action.

There is another important question in connection with the renewal of Leclanché's battery, and that is the question of reoxidising the manganese after use; but, although this is successfully done

by many chlorine manufacturers, the methods employed could not be made use of for oxidising the waste products from a Leclanché battery.

I may mention that the sal-ammoniac used for charging this battery usually contains more or less iron, but this does not injuriously affect the working of the battery, as it is simply precipitated by the ammonia liberated in the battery. The sal-ammoniac of commerce may therefore be safely used.

And now, Gentlemen, before resuming my seat, I must beg to explain that I intentionally selected the comprehensive title I have given this paper, in the hopes that those Members who have devoted attention to the subject of new galvanic arrangements would favour us with descriptions of their inventions or improvements, as the case may be; and I hope this intention on my part will be considered a sufficient excuse for my not having adopted the more modest title of "A Paper on some Points connected with the Maintenance of the Daniell's and Leclanché Batteries," as the latter title would far more fitly have described its contents. There is, I think, no doubt that we have not yet got the battery of the future, but the large number of Daniell's and Leclanché's batteries in use, and the immense sums annually spent upon them, must be my excuse for having occupied your time so long as I have in reviewing some of the causes which affect their working. In conclusion, I must beg to sincerely thank Mr. A. Bell for the valuable assistance he has given me while preparing this paper.

The CHAIRMAN: We shall be happy to hear any remarks upon Mr. Roberts's paper. I hope you will not fail to observe that he has invited any questions about batteries generally, therefore it will come fairly within the scope of this paper.

Mr. ALEXANDER J. S. ADAMS: Although I cannot hope to throw new light upon the chemistry of the battery cell, I rise to submit a peculiar feature, which, whilst not hitherto noticed, so far as I am aware, may be interesting and apposite to the subject before us.

Having occasion to compare the internal consumption of material

and the electro-motive force of a Daniell battery, when that battery was joined through an electro-magnet coil, without armature, with that of the same battery when the electro-magnet armature was applied and caused rapidly to break and complete the circuit, it was observed that with the same consumption of material the electromotive value of the battery was considerably greater in the latter case. To illustrate this, if after a battery has been joined through a non-vibratory bell-coil, and the bell-armature spring strengthened until the bell-magnet fails to attract it, the battery be for a few seconds passed through the vibratory electro-magnet and again shunted to the bell-coil, the bell-armature will become energetically attracted, and this increase of force will be found to obtain for some seconds. How is this? It transpired that with every vibration of the armature the electro-magnet induced current passed in an opposed direction into the battery, and reduced the partial depolarization of its negative plates. If, however, the vibrating armature be caused to make contact with a lower stop, and the stop is connected to the electro-magnet coil in such a manner that the induced current may freely circulate, this improvement to the electromotive force does not occur.

I have applied the principle of this difference of electromotive force as a comparative test for batteries, and by it find that the relative depolarization of the Fuller bichromate cell compares very favourably with the Daniell.

Mr. D. G. FITZGERALD: I think this paper, though it deals with details, is of considerable practical importance, and, as the older electricians are mostly engaged in original research, it is very expedient that some of the younger electricians should take up these points of detail as thoroughly as Mr. Roberts has done. There is one point in connection with the working of the Leclanché battery to which I think he has not referred. I have not had much experience in this direction myself, but on one occasion I analysed the contents of a spent Leclanché cell, and found in them a considerable quantity of nitrate of ammonia, and it is stated that nitrate of ammonia is invariably one of the products of that battery. I should like to hear whether this experience is confirmed by other observers. It may be interesting to give the equation of the

chemical reaction according to which this salt would become formed, viz.

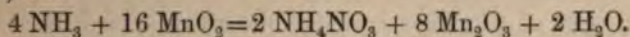

I will now, if I may be permitted, refer to a new oxidant for employment in batteries, which I have tried experimentally, and which might prove of value generally. Great anticipations were entertained some years ago as to the value as an oxidant in batteries of a solution of chromic acid obtained by adding sulphuric acid to a solution of bi-chromate of potash. Those anticipations have been to some extent justified, for the ordinary bi-chromate battery is of great importance to amateurs, and of value in many experiments extending over a short period of time, though useless for practical purposes. The bi-chromate of potash was, in fact, of all the salts of chromium the worst that could have been selected for the purpose in view. The object in adding an acid to a salt of chromic acid was the liberation of chromic acid or of some compound of chromic acid equivalent to it, and, in order to do that to the best advantage, and to obtain a strong solution of chromic acid, we should select a salt forming an insoluble or a non-crystallizable compound with the acid used to liberate the chromic acid. Now the bi-chromate of potash requires ten times its weight of water to dissolve it, and thus affords but a very weak solution of the oxidant, a solution, moreover, having a strong tendency, unless certain precautions be taken, to deposit sulphate of potash in crystals. The precaution is to add sufficient sulphuric acid to form the hydropotassic sulphate instead of the neutral salt. It requires, as I have said, ten times its weight of water for solution, begins with a tendency to deposit crystals, and ends by producing a salt—very beautiful in itself, but highly objectionable in a voltaic battery—which crystallizes in combination with a large proportion of water, viz. chrome alum. The formula for this salt, which is deposited in magnificent violet octohedra when its solution is left for some time at rest, is

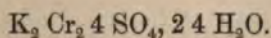

Another disadvantage which should be pointed out is, that this salt of potash is intrinsically more costly than other salts of chromic acid which could be produced—such as the chromates of soda,

ammonia, and baryta—since potash is the most expensive of the alkalis. It may hereafter be regarded as a curious circumstance that, in spite of the high anticipations which were formed of the importance of chromic acid as an oxidant, an oxidant giving in voltaic combinations an electro-motive force rather over two volts, no effort should, for so long a period, have been made to obtain and to use generally a more suitable salt for the production of the oxidant for battery purposes than is the bichromate of potash. The salt I have used for a long time is the bichromate of lime, or, more correctly, the hydrocalcic chromate ($H_2 Ca 2 Cr O_4$). I obtain it for my own purposes in a somewhat expensive way, viz. by adding caustic lime to a solution of bichromate of potash, thus precipitating half the chromic anhydride in combination with calcium, and producing the neutral chromate of potash. I then precipitate half the lime from the chromate of lime by means of sulphuric acid and obtain the hydrocalcic chromate by evaporation. I intended to bring some of this salt with me, and regret not having done so; but if any of those present should require a small quantity of it for experiment I shall be happy to supply it. With this salt of lime (although we cannot precipitate more than half of the lime by the addition of sulphuric acid) we obtain, by adding sulphuric acid in excess, what virtually amounts to a strong solution of chromic acid; and, in presence of this energetic oxidant, “polarisation,” with a carbon cathode, becomes evidenced only when a battery is more or less “short-circuited.” I take this opportunity of protesting against what I consider a great mistake in testing batteries adapted for telegraph work, viz., the plan sometimes adopted of short-circuiting such batteries. If I require a battery to work through a resistance of eight or ten ohms, I construct one specially for this purpose, and I do not then aim at long-continued action. I think some electricians are rather unreasonable in their expectations of batteries. It is futile to expect every advantage at once in the same battery. If you want cheapness, long-continued action, and constancy, you can hardly expect to have at the same time a battery which you can circuit through a resistance of one ohm or less, or even through a considerably higher resistance, without obtaining strong signs of *polarisation*, and exhausting the battery rapidly. In connection

with the subject of this evening, which, I think, ought properly to have been styled the "Chemistry of the Voltaic Cell," I might speak for a long time; but, as there are probably others who would like to make observations upon the paper, I will now sit down.

The PRESIDENT: There is a chromate battery on the table, made, I believe, by Mr. Fuller. I think Mr. Rudall has had some experience with that, and I would ask him if he knows anything about its construction?

Mr. RUDALL: Judging from the paper read, I hardly thought that the question would come before the Meeting, but that it would be confined to the Daniell's and Leclanché batteries. I think, with regard to the non-employment of bichromate batteries for telegraph purposes, the results which have been obtained on the Chatham and Dover Railway may be of interest. We have several circuits worked by means of this battery, introduced by Mr. Fuller. We had a needle circuit of 78 miles with 10 single-needle instruments, which we worked with 60 cells of the ordinary Daniell sulphate battery. This is now replaced with 24 of these Fuller cells, which have been at work since the 1st of May, 1876, and which have only been refreshed once with a small amount of bichromate of potash and sulphuric acid. That is a trough battery. That circuit is now at work, and it is a very interesting one, as the 24 cells have done more than the 60 cells of Daniell. Of course at night it is at rest. I thought it only fair to try the Leclanché battery against the above. I therefore selected, about two months later, another circuit of 92 miles, with 10 single-needle instruments on it, and put on 24 Leclanché (No. 2 size) cells, and that circuit has worked equally well. The cells only require a little water now and then. I can speak favourably of both these batteries for needle circuits. We have worked both circuits without any trouble, one since the 1st of May, 1876, and the other about two months later, and both are working well. Of course we all know that the Leclanché cell is not equal to the other upon a closed circuit: it soon loses its power and breaks down. I asked Mr. Fuller to let us have some larger bichromate cells to work our printing circuits. We have one of these on a Metropolitan District circuit of 10 miles and 10 instruments, and we work that with a constant current.

We used to work this circuit with 60 sulphate cells at one end and 40 at the other end of the circuit. This is always in use, night and day. Twenty-four of Fuller's quantity bichromate cells have replaced the 60 at one end, and the 40 sulphate cells at the other end have now been replaced by 12 at Victoria, and we find these 36 cells work the circuit perfectly, in place of 100 sulphate cells. They were put to work about a month ago. They require $1\frac{1}{2}$ lb. of sulphuric acid to be added every ten days or a fortnight, and about 20 lbs. of bichromate have been used since the 6th of October last. We have now another printing circuit of 10 miles, with 6 instruments, worked with 20 quantity cells, and these are in use, with a constant current, from 7 in the morning till 10 at night, and have required only about 2 lbs. of sulphuric acid since the 9th of February last. We have also four quantity cells, brown ware, rather larger than those spoken of. On the 1st of February last four of these cells replaced 10 sulphate cells on a distant signal indicator circuit, and they have not been touched since: they are working with reverse currents. Then we are trying two quantity cells on a constant block instrument circuit, working for a short distance from Victoria to a bridge over the Thames. This was started on the 5th of April, and has worked well since. That is a constant current, with the exception that, when the signal "line clear" is given, it is relieved for a few seconds. Lastly, we have five cells of the bichromate battery, replacing 16 sulphate cells, working a very busy block needle circuit from the Grosvenor Road station. The whole of the down trains—about 300 a-day—passing from Victoria are worked with that instrument, and it is in use night and day, but the current is only employed during the passage of each train. Our experience has hitherto been much in favour of these bichromate batteries. In the case of the sulphate battery, there is a great waste of sulphate of copper in closed circuits, whereas we have used, as I said, only 25 lbs. of bichromate and about $1\frac{1}{2}$ lb. of sulphuric acid per week, since the 6th of October last, on a busy closed circuit.

The CHAIRMAN: In what does it differ from the ordinary bichromate battery? Do you find it requires more attention than the Daniell?

Mr. RUDALL: No. The only objection is, sometimes it will suddenly fall in power if not watched. It requires careful watching. By adding a small quantity of bichromate or sulphuric acid, as the case may be, it is restored at once. I am very satisfied with these batteries, and intend to extend the use of them.

Mr. HIGGINS: I cannot give any fuller information on this subject, but I can give you my reason for using bichromate of potash instead of lime. Bichromate of lime is not manufactured commercially in this country, and bichromate of ammonia is much too expensive. It costs 11s. per lb., therefore we cannot use that, whereas bichromate of potash is only 4 $\frac{3}{4}$ d. per lb. Whatever advantages there may be in favour of bichromate of ammonia or lime we cannot use them on account of the great cost. As to the deposit of chromate of alum I do not know how that is, but we do not get any deposit in our solution of bichromate and water. Our batteries are used to produce electricity, and therefore they never arrive at that point.

Mr. FITZGERALD: I would observe, that, if you wished to experiment with the bichromate of lime, you would have at the present time some difficulty in obtaining any, and you might possibly have to pay even 8s. or 10s. per lb. for it. But, surely, if it were shown that the bichromate of lime was more advantageous in every respect than the bichromate of potash, the present high price of the bichromate of lime (which is due merely to its rarity) is an obstacle that could soon be surmounted. As a matter of fact the manufacture of bichromate of potash almost invariably involves the preliminary production of chromate of lime, which salt is subsequently decomposed by the carbonate of potash. On a large scale you could obtain more cheaply either of the two other alkaline carbonates than this carbonate of potash. Lime, as a base, would practically be still cheaper. It is calculated if bichromate of potash can be made for 5d. per lb. bichromate of lime ought not to cost more than 2d. The main expense of manufacture in the case of all the chromates is not the chrome iron ore; that is to be obtained very cheaply. The other day I heard that several tons of it were thrown into the river to make the foundation of a bridge. The main cost is for fuel consumed in the reverberatory furnace, and

the alkali potash, which is almost invariably used in the production of a chromium salt. If a few electricians wished to obtain a considerable quantity of the calcic salt, they might easily obtain it at a low price. I have recently seen a description of a battery invented by Mr. Fuller, in which I understand the oxidant to be the bichromate of mercury, which, with sulphuric acid in excess, would constitute a very powerful oxidant.

Mr. HIGGINS : The zinc is immersed in mercury.

Mr. FITZGERALD : I imagined that the battery was maintained in action by mercury chromate or bichromate. The mixture of bichromate of potash solution and sulphuric acid is the fluid which I hold to be objectionable, and which I propose to supersede by a more concentrated oxidant, having no tendency to deposit crystals. Amateurs use bichromate batteries of the ordinary single-fluid form to a considerable extent. They are careful not to leave the zinc immersed in the bichromate solution for any length of time, otherwise the chromic acid would be soon reduced to the condition of sulphate of chromium, and with the sulphate of potash would constitute chrome alum. With these batteries, although the initial electro-motive force is very high, this force rapidly falls, not on short circuit only, but even when a considerable resistance is incurred between the poles, and my own experience of batteries worked by the ordinary bichromate fluid is, that unless a considerable amount of attention is given to them you will obtain a great mass of these magnificent crystals of chromic alum, which are objectionable, since they increase to almost an unlimited extent the internal resistance of the battery, crystallizing the carbon plates and also the zinc.

Mr. HIGGINS : We have used this ordinary bichromate battery, in which this objectionable crystallization is said to take place, for five years without having noticed it. We use them every day, and we have never noticed these crystals except when the battery is exhausted, but we never allow it to get into that state in practice. Using a concentrated solution of chromic acid would rapidly destroy the mercury, and every oxidizable solution would be rapidly oxidized. Troughs of marine glue would be unable to work for a single day. The dust and fibres of vegetable matter in the wood

decompose it very rapidly, and in addition some sulphuric acid must be added to increase its conductivity. A solution of chloric acid does not act better than a solution of sulphate of potash made up with sulphuric acid. The sulphate of potash and pure sulphuric acid facilitate the passage of electricity through the liquid.

The CHAIRMAN: Can we obtain any further experience of these batteries from those who have used them? If no other remarks are offered I will call upon Mr. Roberts to make any observations he thinks fit in reply.

Mr. ROBERTS: There is one rather interesting fact connected with the Leclanché battery which I have not referred to in the paper I have just read, that is, that if a Leclanché cell is charged with a large excess of sal-ammoniac and heated to about 212° F. we get a battery with far lower internal resistance than a Grove's cell with the same size plates would give, although, of course, it is not nearly so constant.

With reference to what has been said about Fuller's battery, and to Mr. Fitzgerald having stated he was under the impression that bichromate of mercury was used in it, I think this misapprehension has arisen through its being generally called "Fuller's mercury-bichromate battery," its distinctive feature, and in fact the only point in which it differs from the bichromate battery which has been in use for years, being that the lower portion of the zinc plate rests in a reservoir of mercury. The large quantity of mercury used in the present form of this battery is however, in my opinion, objectionable, not only on account of its expense, but because it frequently dissolves the lower portion of the zinc plate, and when wires of a large gauge are used to connect the plates in one cell with those in the next, as is usually the case, they frequently support the undissolved upper portion of the plate in the cell right above and out of reach of the mercury, and the battery then soon exhausts itself, owing to the local action which quickly commences on the unprotected zinc plate. I cannot say very much as to what chance there is of Fuller's bichromate arrangement breaking down through the formation of chrome-alum as I have had few opportunities of examining the solutions in this battery when working, and, although I had one sample of this salt sent me some time ago

to say what it was, I have not since found in any case that a large quantity of the crystals had made their appearance on the carbon plates, although I have examined a very considerable number. I am quite of Mr. Fitzgerald's opinion, that bichromate of calcium could be obtained at a low price if a large quantity were required, although I am not able to give the results of any experience which would warrant my expressing an opinion as to the advisability of using that salt in place of bichromate of potash; but I may state that some two years ago I had occasion to ask a firm at what price they could supply the calcium salt, and they quoted, I think, 2s. 6d. or 3s. per lb., but mentioned that if a large quantity was wanted they would be able to supply it at a very low figure, probably, I should imagine, at a few pence per pound. I do not, however, think that Mr. Fitzgerald is quite correct when he states that in the manufacture of bichromate of potash from chrome iron ore bichromate of calcium is first produced, as I have always understood that the only reason chalk is mixed with the powdered ore, when it is heated with carbonate of potash in the manufacture of bichromate of potash, is to prevent the fusion of the mass in the furnace.

There is another point which Mr. Fitzgerald has called our attention to, which is, I think, of the greatest interest, and that is that nitrate of ammonia is usually, or always, one of the substances found during the working of the Leclanché battery, but I wish he had informed us what is the largest per-centage of this substance he has ever found in the salts taken from a Leclanché cell, for I am inclined to think the quantity formed is so small as not in any way to affect the working of this battery.

The CHAIRMAN: Whatever may be the difference of opinion as to the merits of batteries, there can be only one opinion, I am sure, as to the great practical value of the paper which Mr. Roberts has brought before us to-night. We very much want, and always have wanted, the assistance of chemists who will take the trouble practically to discover the nature of the operations within the battery which are not to be seen by the eye, and which are unknown to most people who are not chemists. Therefore papers of this kind are of great practical value, and we must all feel indebted to Mr. Roberts, Mr. Fitzgerald, and others, who have enlightened our

views on the nature of the changes which go on in our batteries. I agree with Mr. Fitzgerald that chromate of lime might be brought to be a cheap ingredient, and we cannot but appreciate his kind offer to send specimens of it for experiment to Members who would like to use it. I hope some of our Members will take advantage of the offer, and will experiment upon the value of this chromate of lime. Mr. Fitzgerald gave me some of it two or three years ago, and I tried experiments with it which convinced me in a satisfactory manner, but, having to go abroad at the time, it was neglected; but, from what I learnt at first, I formed a high opinion of it. I do not know what to think of batteries: we have such good accounts of the bichromate battery, the Leclanché, and others, that we must form our own judgment of their respective value. I hope in due time we shall have further information on this subject, in order to determine what shall be the battery of the future. I have great pleasure in proposing a vote of thanks to Mr. Roberts.

The proposition was unanimously agreed to, and the Meeting adjourned.

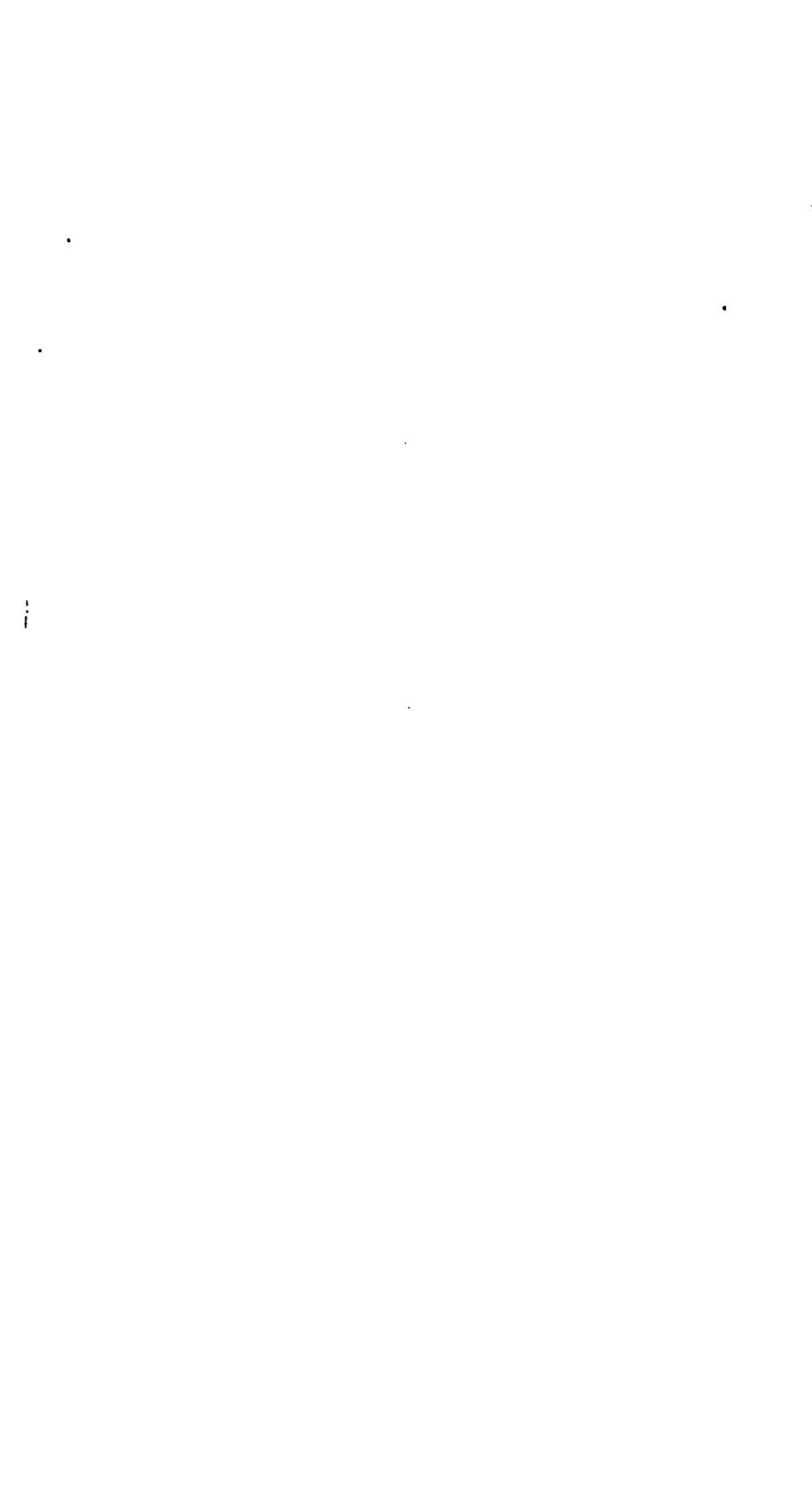

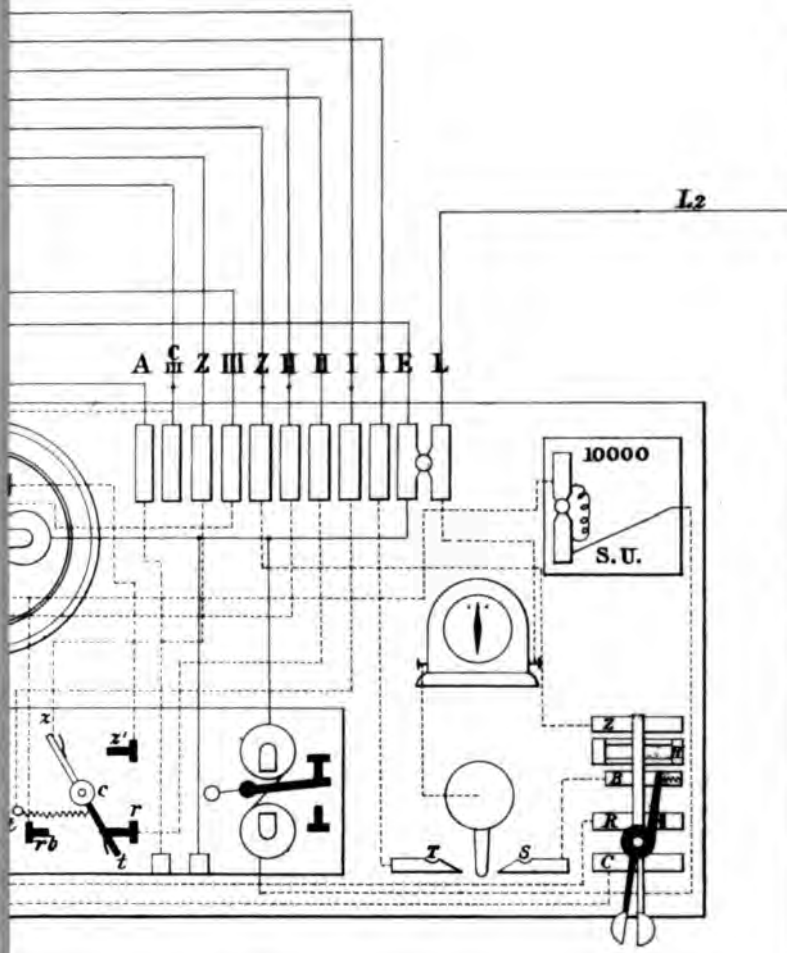

App. II.



electrical contacts and adjustments, or rely upon the strict attention of an operator. With that view, the bracket or cradle of the sending key of the early days was provided with a vertical axle, so as to give the lever a horizontal motion, and it had to be held over laterally against the tension of a spring for sending, an operation which required some practice, and was rather fatiguing to the operator. It would return when released by the hand, drawn by the tension of the spring, into its position for receiving, and discharge the line direct to earth on its road before reaching the relay contact. That key, which originated in 1858, is described and illustrated in Dr. Schellen's German work on Telegraphy, published in 1870, page 550. It has since undergone several modifications, without deviation from the general principle. One form is carefully illustrated and described in the same work, page 552, and is an acknowledged improvement of the older form, no longer trying to the arm of the operator, nor requiring special skill, as it works just like a single-current key. It is best explained by comparing it to a pair of scissors with one shank insulated from the other when open. Both parts, being held together by the hand of the operator when sending, are brought into metallic contact, and rock together on one common horizontal axis, like an ordinary sending-key, making contact up and down to zinc and copper respectively; but, on the operator's hand releasing the handles, the upper half, which is in contact with the line, ascends until its corresponding back part comes in contact with the relay stop for the receiving position, thereby breaking contact with the lower half, which communicates with the poles of the battery. During a portion of the time of both ascent and descent of this upper half, to which line is attached, direct contact to earth, for the purpose of discharging the line, is made by the action of a spring upon a little crank lever before bringing the relay in direct contact with the line, on the one hand, or before sending any fresh currents into it, on the other hand.

The latter key, designed in 1869, is the key actually used by the Indo-European Company's clerks since the erection of their lines.

The sending-key, as shown on the diagram, and as applied to the instruments which, through the kindness of Messrs. Siemens, I am enabled to place on the table before you, is still of a later origin.

and still easier to manipulate. Designed in 1875, it has been supplied lately in that form to the Indo-European Government Telegraphs for their lines, in continuation of those of the Indo-European Company. The scissor-like arms of the lever of the key open and shut horizontally on a vertical axle, each part carrying a portion of the key-knob. They are held in contact by the slightest touch of the operator's finger, and move conjointly up and down on a horizontal axis for sending, like an ordinary key.

The early Indo-European inker, although in matters of detail of a novel construction at the time of the erection of the Indo-European line, yet contains all the principal parts of the so-called "Submarine Inkers" of 1858, which, in conjunction with the key above-mentioned, we find described in Schellen's as well as Sabine's early editions. The first marking current passing through the coils of the inker starts the train of wheels automatically. This action at the same time causes a mechanical automatic switch to change position, which changed position it maintains while the clockwork is running. During the position of rest this mechanical switch holds the coils of the receiving instruments connected with their respective lines, while, when the train is in motion, it connects, during that time, the translating lever in action with the line to be translated into, and also the zinc pole of the main battery to the rest-stop of the translating lever. The earliest Indo-European instruments were polarised direct inkers, *i. e.* the reversals arriving by the line were passed direct into the coils of the inker, the writing lever of which, at the same time, acted as translating lever. That instrument will also be found illustrated and described in the 1870 edition of Schellen, page 618, &c., and its origin falls together with the key of 1869. It having been superseded, however, by an improved arrangement since January 1874, I need not further dwell upon it, as the principal parts are preserved in the present instrument, specimens of which are on the table.

The present arrangement is in so far, perhaps, novel that it is *neither a proper direct acting circuit, as there is a relay in circuit acting upon the inker; nor is it an ordinary local arrangement, as there is no local battery.* Yet, inasmuch as the tongue of that same *relay*, the coils of which receive the currents arising from one side

of the translating station, acts at the same time as translating lever for both zinc and copper currents which are being translated into the line at the other side of the station, it must be pronounced a direct acting circuit. The coils of the recording instrument are placed in a shunt circuit of very high resistance (usually 10,000 units) branching from this translating circuit. The inker abstracts, therefore, a corresponding small battery power from the translating main battery, and is thus an actual duplicate and faithful recorder of the signals sent into the line by the translating lever of the relay from the "line" battery, and thus a great deal more reliable than signals obtained by an intervening "local" battery.

The plans show diagrammatically the principal parts of the instruments, and also the way they are connected up.

Each half of a translation set is mounted on one general base board, as shown on the plan marked "Special." It has been invariably the custom of Messrs. Siemens to advise this arrangement, as it is easily connected up, and, if anything should happen to one half set, it is easily disconnected and replaced by a spare half set, whereas otherwise a complete spare set would be required.

The Permanent Hand-switch.

There is only one hand-switch to each board, marked on the plan S and T, which requires permanently setting, once for all, to either S for station-to-station correspondence, or to T, for translation correspondence. The former position puts the sending-keys in communication with their respective line wires, and the latter position places the relay tongues to line. All further switching is performed automatically by the apparatus itself.

The Sending-key with Automatic "Send and Receive Switch."

The sending-key is represented on both the "Special" and the "General" plan by the terminal slabs C, R, B, Z. Crossing them transversely is an ordinary Morse key hinged upon H, and shown in white upon the plan. A second lever shown in black is hinged horizontally to the fore part of the lever key, which, turning upon the hinge *h*, and drawn by a spiral spring fixed to the slab B, opens similar to a pair of scissors until it rests against a projection of the

slab R. It will be seen that the slab B and with it the shaded part of the lever (by means of the spiral spring) are in constant contact with the line when the hand-switch handle is turned to S, and thus in its position of rest currents arriving can pass from the line through galvanoscope switch S, B, and R through the coils of the relay to earth.

Thus the main lever of the key is, in this position, a dummy only. But when the hand of the operator, when sending, unites the split handles, the shank of the insulated part, in making contact with the main lever, withdraws from the projection on slab R, whereby the relay is disconnected from and the zinc pole of the battery put to line, since the main lever rests on the back contact Z, to which zinc is attached, and a depression of the key sends copper to the line, as C, the front contact, is connected with the copper pole and the middle of the battery to earth.

On the withdrawal of the hand of the operator from the key-knob the split lever opens again, and, resting against R, re-establishes automatically the communication with the relay for receiving.

The Polarized Inker with self-acting "Send and Receive" Switch, Fast and Slow Speed Regulator, and Self-starting Gear.

It is the combination of the self-starting gear with the switch lever which constitutes the originality of this instrument. The mechanism is applied to the back of the inker, and is represented in fig. 3 of the plan.

An arm, i , is fixed to the axle of the grooved drawing-off drum u of the clockwork, and rests with its end against the axle h , thus stopping the motion of the clockwork. At the place where it touches the axle an incision is made into the latter, cutting away half the cylinder for the width of the arm i , and the axle is so placed that the end of the arm i rests against the edge of the incision, so that a slight movement of the axle h round its own centre may allow the arm i to pass under, and the train of wheels to run. Fixed rigidly to the axle h is also the bent lever-arm g , which carries on its lower extremity a pin, which catches into a little hook

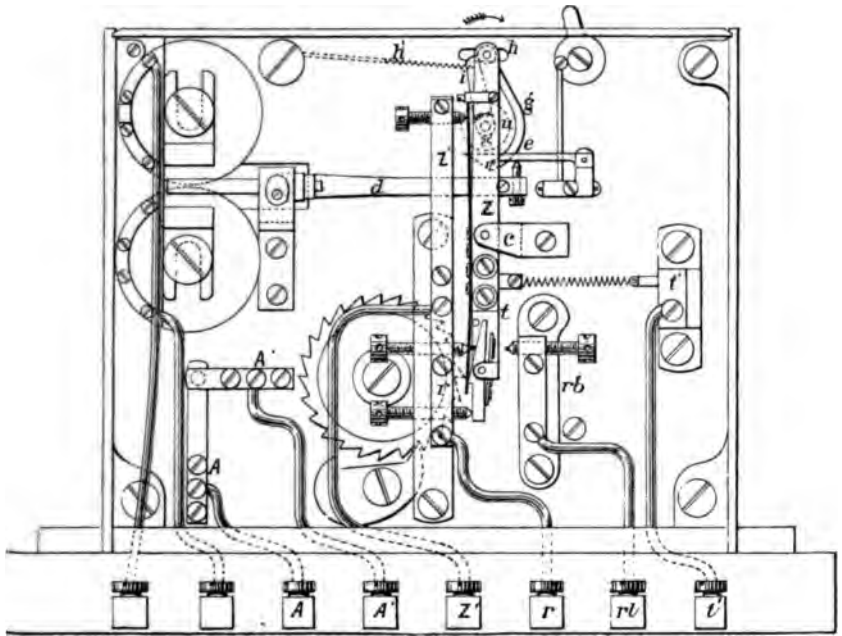

Fig. 3.

at the end of the lever *e*, and, when thus caught, the spiral spring *k'*, which tends to turn the axle *h* round its own centre, is prevented from doing so. (Pos. I. fig. 4.) On the elongation *d* of the writing

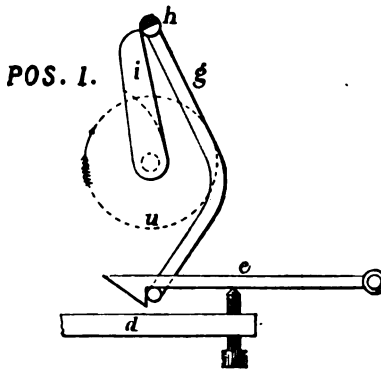

Fig. 4.

lever striking against lever *e* from below, the little pin is released from the hook on *e*, the spring *h'* can contract and turn the axle *h* through the incision in which arm *i* now can pass, and the clock-work starts running. Thereby the bent lever *g* has been thrown over to the left until the inner edge of its curved part strikes against the arm *i*. (Pos. II. fig. 5.) A projection from this arm *i* now

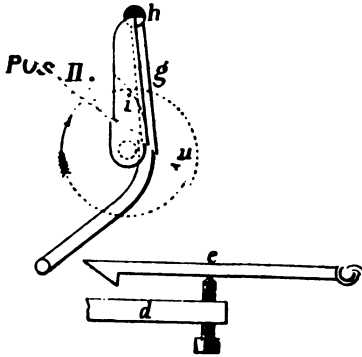

Fig. 5.

engages with the curved inner edge of the bent lever *g*, thereby extending the spiral spring *h'*, and, forcing the lever over from left to right, passes the little pin on *g* under the hook on *e* in the same direction during the first quarter of its revolution to the right. (Pos. III. fig. 6.) During the second quarter of the turn the pin

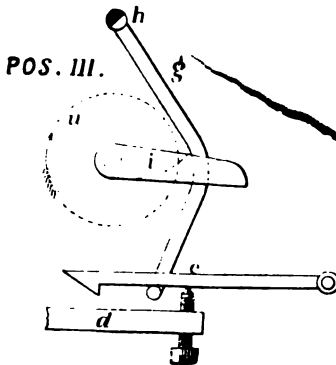

Fig. 6.

returns from right to left, drawn by the now contracting spring h' , and leaves it engaged in the hook on e , when, having nearly completed the second quarter of a revolution, it points downwards. (Pos. IV. fig. 7.) Thereby the axle h has assumed its original po-

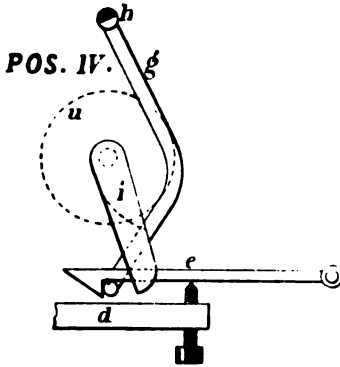

Fig. 7.

sition, so that, when now arm i has made one complete revolution, it must strike against the edge of the incision on h , and is arrested, and with it the clockwork (Pos. I. fig. 4.) Each marking current, therefore, which passes through the coils of the inker at intervals exceeding the time it takes arm i to make one turn, will start the clockwork, allow the drawing-off drum to make one revolution, and then arrest it again. If, however, currents arrive in rapid succession, as they do when a message is being sent, the little pin cannot engage with the hook on e , which is constantly being struck by the elongation of the writing lever, and, even if it should happen to be caught, it would require, in order to stop the clock, a quiescent state of the armature for the duration of rather more than the latter half of the revolution of arm i , viz., from the time of its locking of the pin on g with the hook on e till the arrival of the arm at h , which, being almost three-quarters of a turn of the drawing-off wheel, is not likely to happen in practice. Part of this arrangement, as, for instance, the employment of axle h with its incision, is not new, and has been repeatedly employed before by others for

similar purposes; but it is the combination of this self-starting gear with the automatic switch which mostly deserves our attention. The switch lever is represented by Z, c, t . Its upper extremity, Z , is in metallic contact with the body of the instrument by means of its centre, C , upon which it turns, the standard supporting the same, and also one end of axle h , which is pivoted to the upper end of Z on the side turned towards the spectator, and to the frame-plate of the clock on the other side. That end of axle h which is turned towards the spectator can therefore partake of the oscillating motion to the right and left of the lever Z . The lower extremity of this lever is insulated, and stands, by means of a spiral spring, in metallic communication with the terminal t' , which, being connected to T of the hand-switch of the fellow set of apparatus, thus communicates with the line whence a current arrives. The tension of the mainspring of the clockwork gives a tendency to the arm i to turn to the right (as indicated by an arrow), which causes the arm to press against the end of the axle h , which is pivoted in the extremity Z , and thus holds both axle and lever over to the right until the insulated lower extremity t bears against the contact r , which again communicates with the relay coils of the fellow set of instruments. This being the position of rest, it will be seen that any marking current arriving by any line can pass from L , galvanoscope, T, I to I' of the fellow apparatus, and over t', t, r, II , back to II' , and into the relay coils of the original set, and thence to earth. Thus the relay speaks and the inker starts, because, the tongue of the relay having been thrown over to the stop C , which is the copper pole of the main battery, a marking current passes over the relay tongue, the 10,000 units' resistance, and the inker coils, to earth. The self-starting gear of this inker now being set in motion as explained, the pressure of the arm i upon the axle h ceases, and the spiral spring connecting the lower extremity t with t' , together with the spiral h' acting upon the upper extremity, can now pull the lever over into the opposite position, until the insulated lower half rests against rb , and the upper part Z against the stop Z' . By that means zinc of the main battery is put to the second relay stop, and the line to be translated into, to the relay tongue,

which now acts as double-current sending-key, the currents from which divide themselves between the line to be translated into and the home inker, in the proportion of their respective resistances. The mechanical switch of an inker at rest, therefore, stands ready for receiving from either line in such a manner that the switch of the "down" inker connects the "up" line with the "up" relay, and the switch of the "up" inker the "down" line with the "down" relay. The switch of an inker in motion puts the line to be translated into to the tongue of the receiving relay, and also zinc to the rest-stop of same. From the above, the passage of the current in either direction will be easily understood, and also the peculiarity of the system, which has only the electro-magnet coils of the receiving relay in the direct circuit; the tongue acting the same as a direct acting translating lever, and the recording inker forming a derived circuit from the same. Hence arises the facility with which this system can be transformed into a double-current duplex system, on either the bridge or differential method. The Indo-European Company might with advantage avail themselves of this method in order to duplicate the comparatively short length of about 300 miles of single line from London to the Continent which they rent from the English Government. Having a double wire, I believe, the rest of the way, this alone would at once almost double the capacity of their line.

As long, now, as the clockworks are kept wound up, the automatic commutating will go on as described, and an omission of doing so when the clockwork is run down will, of course, immediately stay that action. In order to obviate this, a mechanism has been attached to the winding-up barrels of the instruments which causes two otherwise insulated metal springs, communicating with a battery and chattering alarum, to make contact a little time before the mainspring is quite run down, and thus to sound the alarum, which serves as a reminder to the attendant that the time for winding up has arrived. A and A' represent those two springs, which make and break contact accordingly, and the circuit is easily traced from Plan II.

It has been objected that for the kind of sending key described

above double the number of elements are required than with the key which is mostly used for a similar purpose in this country. It will be seen however from the plan that the double number of elements also serve two keys, so that, for translation or intermediate stations at least, it amounts to the same. Only when the two lines are of different lengths and two batteries of different strength are required, the poles of the smaller set are shifted more towards the middle of the battery, and in that case this system would require a few elements in excess, *i.e.* where one set of 30 and another of 40, total 70 elements, are required, this system would require twice 40 elements, if arranged as shown on the plan. But by a very simple arrangement the key is so modified as to act from a single battery, and in that form it is used for terminal stations, and applied to the instruments on the table representing terminal stations.

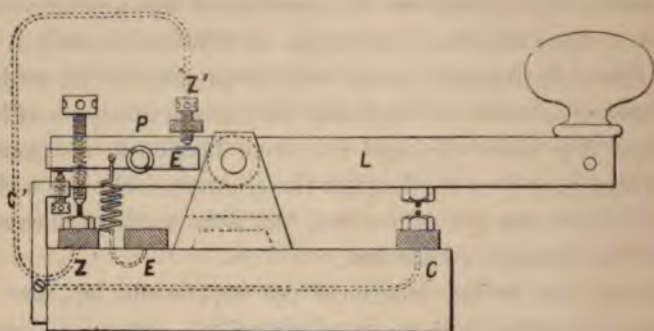

Fig. 8.

Figure 8 shows the arrangement referred to minus the automatic switch described before. L is the lever of the key, with Z and C the ordinary back and front contacts. E is a similar little two-armed lever fixed to the back part of L, but insulated from the same, and, working upon a pivot P, is drawn by the spiral spring, which, at the same time, acts as the working spring to the key, against the stop C', while the main lever L, drawn by the same spring, rests upon the back contact Z. The little lever E is in communication with earth by means of the spiral spring, and the

stop it now rests upon communicates with the copper pole of the battery. When, therefore, the hand of the operator unites the two parts of the knob of the key he puts zinc to line, the copper end of the battery being to earth. A depression of the key brings the lever *E* to bear against the top stop *Z'*, which causes it to break contact with *C'*, when, by a trifling further depression, the main lever *L* strikes upon the front contact *C*. Thus the line, which was before to zinc, is now to copper, and the earth, which was before to copper, is now to zinc.

In this form therefore the key requires but the single number of elements for reversals.

The construction of this key also recommends itself as a convenient form of constant resistance key for duplexing, and is thus a modification of an arrangement proposed several years ago by J. F. Vaes of Rotterdam (Schellen, 1870, p. 682). For duplexing single currents the little lever *E* is not insulated from the body *L* of the key, the lower stop *C'* is in metallic communication with the back contact *Z*, and the upper stop *Z'* with the front contact *C*. Then, while *L* is depressed, *E* would maintain the back contact until it strikes against *Z'*, thereby simultaneously interrupting at *C'* and putting battery on at *Z'* a little time previous to *L* reaching the front contact, and maintaining the same until *L* returns far enough for *E* to touch *C'*, which causes the battery-contact to be broken and the rest-contact to be re-established in the same instantaneous manner.

For duplexing double currents the key is supplied with two such little side levers as are represented in *E*. They are placed one each side of the main lever, the one insulated from it and communicating with earth, and the other, not insulated, with line. (The latter is not shown on sketch.) Their respective top and bottom stops are reversed, so that when the key is resting on the receiving contact the main lever as well as its lateral non-insulated companion rest on zinc, and copper is to earth by way of the insulated lever *E*. A partial depression puts the latter to zinc and the former to copper, and so on in the same manner as above described. If the play between both lateral levers and their stops be equally adjusted, then they must make and break contact simultaneously; but, if not,

then there will be a short interval between each change of current, in which the line would be, for an infinitely short period of time, in direct contact with earth, which, if not actually assisting our working, cannot do much harm, as the discharge of the previous current must be in the same direction as the following current. There is no difficulty, however, in adjusting the play perfectly equal and in obtaining perfectly instantaneous and sparkless breaks.

It will be seen also that for an instantaneous charge or discharge key, or for any contact without interval requirements, this arrangement offers every facility.

The very useful agency of translation to work very long lines with increased speed and accuracy has as yet been made very little use of, so far, at least, as any number of translation stations in the same circuit are concerned. Some telegraph engineers to this day will not acknowledge translation as a reliable means of coupling up long lines, and a circuit with several translation stations is still looked upon as a feat more fit for the experimenting room than for actual working, the same as was duplexing till very recently. Frequently therefore we find the advantages of recording messages on long circuits lost sight of, and recourse had to a system of visual and other signals, which of necessity lead to the many errors we daily find in our telegrams. It was left to the enterprise of Messrs. Siemens to pioneer in that direction for translation, and prove, by this compact yet simple arrangement, the practicability of effectually working a circuit of 3,800 statute miles in length, which has now been done uninterruptedly since the opening of the Indo-European Company's line on the ordinary direct inker translation principle, and since January 1874 on the relay system just explained. It is obvious that upon a line of such length circumstances will prevail which necessitate the working in sections, such as partial low insulation, storms, breaks, contacts, &c. and you cannot fail to observe the facilities given for switching the sound sections together and leaving the faulty ones to fight their way through until they recover.

In such cases retransmission, of course, becomes necessary, but can always be maintained at the minimum.

It has latterly been found advantageous to work the line as a rule in the three following sections : viz.

London 117, Lowestoft 274 to Emden	391	stat. miles.
Emden 325, Berlin 395, *Warxhau 432,		
Gitomir 360, *Odessa 446, Kertch	1,958	„ „
Kertch 400, *Suchum Kaleh 284, Tiflis 377,		
*Tauris 390, Teheran	1,451	„ „
	—	
Total	3,800	„ „

N.B. The stations marked * come in relay only when called.

That the managers of the Indo-European Company find it advisable thus to cut up their line into sections, and limit the number of stations actually translating in each section, is a sure sign that too many intervening translating stations are inconvenient, a circumstance which we can well understand, since the too frequent automatic re-transmissions must seriously interfere with the original duration of the marking and spacing currents even with the best regulated instruments, and I do not, therefore, desire to be understood to advocate translation up to any amount; on the contrary, of actual translating stations there should be as few as possible. But what I do advocate is the establishment of a well-organized system, thickly studded with translation appliances of long range but in short intervals, so as to enable the engineers to shift them at will, as climatic or other circumstances, over which we have so little control, may demand.

That, on the other hand, under favourable circumstances, that is to say, a good line throughout, it is easy to carry on simultaneous through translation to India has been proved over and over again; and I need hardly remind you of the telegraphic feats performed at the Meeting of this Society at the Albert Hall in July 1872, when the Grand Vizier of Persia sent a warm message of congratulation to the Prince of Wales without retransmission straight from Teheran, as reported in the "Times" of 20th July, 1872, on which day also Kurrachee, Calcutta, and Bombay were freely communicated with. Even as far back as April 1871, in the "Times" of the 10th of that month we find that a well-known engineer of the Indo-European

Government telegraphed to his department in London from Kurrachee, 5.36 P.M. April 8th: "This message is the first really sent from India to England simultaneously. By Indo-European line we work now easily and quickly direct with London. WALTON." Also that commercial messages were being forwarded in that manner to Kurrachee for Calcutta, that Kurrachee put the line direct "*through*" to Bombay, and that a commercial message was sent to Bombay direct by London at 1.58 P.M. which was instantaneously acknowledged, the distance thus telegraphed being above 6,000 miles. The daily papers of the 1st of June, 1872, reported the astounding fact that telegraphing the result of the Derby to India by the Indo-European Company took—

To Kurrachee	1 minute.
To Bombay	1½ „
To Calcutta	2½ „

which was said to be the greatest practical telegraph feat on record.

The wide difference thus apparent between the capabilities of multiple translation under favourable circumstances, and the manner in which the system is actually being worked at the present day, give rise to serious reflections, and leave evidently a wide scope yet for improvements in almost every direction. But even in its dissected state the system is fully up to the traffic at present obtainable, and we notice from the records of the Government Telegraph Gazette of Calcutta, of which I append an abstract, showing the average time of transit of messages over the respective lines during each month and for the year 1876, the following general results:

The average time of transit of a message from England to India, as published by the Indian Government Telegraph Department, for 309 competitive working days during the year 1876, was:

viâ Teheran	1 hour	40 min.	40 sec.
„ Suez	1 „	50 „	7 „

That the line viâ Teheran was interrupted during the year of 1876 for 24 days and the line viâ Suez for 35 days. That the line viâ

Teheran alone carried messages to India during 1876 for 34 days and the line viâ Suez for 21 days.

(Record of 16th March missing.)

If we are to understand by this time of transit, so published by the Indian Government Telegraph, the time occupied from the handing in of a message to the English department to the time of delivery of the message in India, then it would be interesting to know how much of this time these respective departments occupy themselves in forwarding these messages.

The Chairman of the Indo-European Company, in his yearly Report to the Shareholders at the general meeting the 28th March 1877, states that the average time occupied per message on their line from London to Teheran was 22 minutes only in 1876, which, if correct, would leave the large margin of over one hour and a quarter for which a message is detained by the respective Government departments.

At the same time it is also stated that the average time of transit of a message from the London Indo-European Office to Kurrachee during the year of 1876 was 57 minutes. We thereby have viâ Teheran.

3800 miles from London to Teheran	22m. Indo. Eup. Govt.
1190 ,, Teheran to Kurrachee	35m. Indo. Eup. Govt.
1800 ,, Kurrachee to Calcutta or elsewhere		43m. 40s. Indian Govt.
	Total 1h. 40m. 40s.

Some of the time shown against the Indian Government Department will naturally fall to our English Telegraph Department, which, failing reliable information, I was unable to take into consideration. I have also not been able to find reliable data to enable me to dissect, in a similar manner, the time of transit viâ Suez.

We cannot but be grateful to the Indian Government Department for the publication of the valuable statistics contained in their Gazette, and I pressinglly recommend to our Home Department the early imitation of so good an example, and I trust they may before long favour us with a similar means of appreciating their zeal and energy for the speedy transaction of business. I fear

however we should find that our home messages take by far a longer time in transit than do the messages to India over some 6,000 miles of line.

There can be no doubt that the capacity of the system introduced in 1874 may yet be enormously increased, not alone by the duplex working of the single line to the Continent above referred to, but also by duplex translating along the whole of the line in sections, which may be reduced in number by the adoption of those faster and more reliable relays with larger range, which at the present day we have at our disposal. Thus the Indo-European Company would have it in their hands to compete with their submarine rival at a nominal outlay.

While I concede that, for lines of such lengths and conditions as the Atlantic cables, satisfactory means for recording messages with any reasonable speed and certainty have not yet been proposed, I would urge on our electricians not to cease striving towards that desirable object by following the footsteps of Sir W. Thomson, who, in his syphon-recorder, has led the way in the right direction, although, perhaps, not fully to perfection yet; and, further, that, pending that result, they should avail themselves more of translation in coupling up long stretches of land or submarine lines in order to secure to the public the benefits of having their messages recorded rather than depend upon the fluctuating and fugitive oscillations of a spot of light, with their accompanying errors and necessary repetitions.

While on the subject of recording I would also say another word in its favour as against reading solely by sound, which seems much on the increase just now, and which I hold to be a retrograde proceeding on the part of telegraph administrations; for, in spite of all the clever clerks we have been educating and are still educating for the purpose, the quality of our telegrams, so far as my experience goes, does certainly not improve by the innovation.

The Morse recorder, being sounder and register at the same time, offers the same facilities to the "sounder" clerk to take down the message by ear in his accustomed manner, as does any sounder, while the registered strip serves as a proof of its correctness or

incorrectness without further repetition or inquiry, thereby saving time. It is a mistake to overlook the value of this proof in all its manifold and important bearings for the sake of the saving of the value of the little slip of paper with its few ink-spots upon it, nor is there any real economy practised by saving the value of the clockwork in first cost of instrument, as no appreciable difference can arise when the cost of the whole line, with station fittings, &c. is taken into consideration. When in our most common daily transactions we hesitate acting upon any "word of mouth" communications, and require our most ordinary agreements and instructions to be made and given to us "black on white," then, I say, it is wrong when telegraph administrations undertake to accept from the public, and pass on by wire, communications of so important a nature as telegrams almost exclusively are, without keeping the slightest tangible proof of how and in what manner that work has been performed, and where and how a mistake, if any, did occur, and it is not wise to issue documents in such numbers, and so full of importance, without a trace of a copy of instructions left in the hands of the issuer. In conclusion I beg to state that I do not point towards one certain kind of instrument as the most suitable for the purposes of recording, as I consider it immaterial in what shape or form records are taken, whether in type, or code, or procured by stylus, disc, or syphon; the one which combines speed and accuracy, with durability, simplicity, and cheapness, is sure to make its way, and that administration which exclusively adopts such instruments for the rendering of their telegrams to the public will supply work of the highest quality, and may issue its telegrams with the greatest confidence, for they retain the certificates of their correctness.

APPENDIX.

Abstract of average Time in Transit of Messages from the United Kingdom to India viâ Teheran and viâ Suez, taken from the Government Gazette, Calcutta, for twelve months, ending December 31st, 1876.

1876.	Viâ Teheran.	Viâ Suez.	Days of Interruption.		Days of Competitive Working.
			Viâ Teheran.	Viâ Suez.	
	H. M. S.	H. M. S.			
January	2	31	.
February	2 36 21	1 56 55	2	2	25
March .	1 33 2	1 29 2	1	.	29
April .	1 11 4	1 19 14	1	.	29
May .	1 8 10	1 15 4	3	.	28
June .	1 13 4	1 11 18	1	.	29
July .	4 5 52	3 0 38	2	2	28
August .	1 27 45	2 3 49	2	.	29
September	1 27 24	3 4 2	1	.	29
October .	1 27 24	2 3 42	1	.	30
November	1 11 28	1 3 24	.	.	30
December	1 25 52	1 44 7	8	.	23
Totals .	18 27 26	20 11 18	24	35	309

Average time for the year per message :—

Viâ Teheran, 1 hour 40 minutes 40 seconds.

Viâ Suez, 1 hour 50 minutes 7 seconds.

The PRESIDENT: The Members are greatly indebted to Mr. Risch, —first, for his clear description of the beautiful arrangement of double-current translation, the mechanical details of which, how-

ever, it is difficult to follow by simply listening to the paper; and, secondly, for the very successful results he has placed before us of this system of recording messages. I have no doubt on the latter subject, which is one of considerable practical importance, we shall have some observations from Members present, which I now invite.

[After a pause, and no Member rising,]

The PRESIDENT said: With regard to these instruments, it must be assumed that those present are hardly in such a position to discuss them as they will be when the paper and illustrations of the mechanism are in print; but it may be deduced, from the silence of the Members with regard to the latter part of the paper, that the observations as to the system of recording are generally acquiesced in. I have now to ask you to return your cordial thanks to Mr. Risch for his valuable paper, after which I will call upon the acting Secretary to favour us with an account which he has drawn up of a new form of electric light, which has recently been experimented upon in Paris.

ON A NEW FORM OF ELECTRIC LIGHT.

I am sensible that I owe to all those present many apologies for laying before them a description of a subject which must necessarily, from sheer want of time to acquire a fuller knowledge of its details, prove very imperfect. This being however the last of the Society's Meetings for this portion of the Session, I am placed in this position—that I must either submit the subject to your notice, meagre as it is, or allow it to stand over till after the recess; but, inasmuch as there is every probability of the invention assuming, even within the period of the recess, a highly practical and tangible form, I thought it might be only meeting your wishes if I adopted the former course, placing you in possession of such information as I have been able to glean, and for the rest throwing myself entirely upon your indulgence.

During the early portion of the past week my attention was attracted to the following notice, which appeared in the Paris paper "La France," dated the 18th April:—

"Towards the end of last year M. Denayrouze made known to the Académie that a Russian Engineer officer had found the means of keeping carbon points together in electric lights without the use of electric regulators. M. Jablochhoff substituted for this costly and delicate apparatus a candle composed of two carbons placed side by side, and separated by and enveloped in an insulating and fusible substance. This forms a very great improvement.

"Since then the efforts of the learned Russian officer have been an uninterrupted succession of advances, and to-day, in a very remarkable paper analysed by the illustrious permanent secretary, M. Denayrouze has called the attention of the Académie to some fresh discoveries. It is already known that not only is the Jablochhoff candle better than any clockwork regulator, but that it is also possible to get several lights from an electric machine. That was a great discovery, and one which made the deeper impression on the Académie, as before coming under their notice it had been practically and publicly proved, for all last week the shops of the Louvre were lit up by M. Jablochhoff's method. But this result was only an introduction to the subject.

"While studying the manner in which the elements of his simple and ingenious apparatus acted physically and chemically, M. Jablochhoff saw that if a strong electric current were passed through a slip of refractory earth, *kaolin* for instance, it immediately, without melting, becomes white-hot, and produces a splendid light, very steady, soft, and noiseless, or, as M. Dumas expressed it, 'dumb,' for there is no combustion.

"The light which was neither dazzling nor blazing showed everything in its true form, and did not surround them with that disagreeable haze and those ghastly shadows of the light produced by the voltaic arc.

"Of course the intensity of the light produced in this way by M. Jablochhoff can be regulated in such a way that the light may be of different sizes, equivalent to one or more gas-lights.

"By a special and very ingenious distribution of the electric

current, to describe which would take up too much of our space, M. Jablochhoff has easily obtained, says the paper, fifty lights from one electric current.

“It is particularly noteworthy that all these lights are independent of one another, and they can be distributed about and lit up all at once, or one at a time; so by this system the distribution of the electric light over any building is exactly the same as the arrangements of the gas or water supply of the present day. The thing is simply wonderful, and we can understand the interest which all the Members of the Académie showed, and the sustained attention with which they listened to the interesting communication from M. Denayrouze. The results which may follow are very considerable, for they may entirely revolutionise the modes of producing light, and make a great advance in the question of producing it cheaply.”

Feeling that the subject was one of peculiar interest to the Members of this Society, I lost no time in placing myself in communication with Mr. Applegarth, of Southampton Street, Strand, the London representative of M. Denayrouze, the manager of the company formed to work the invention; and I am pleased to be able to testify to the extreme courtesy and desire of that gentleman to place at my disposal, for the benefit of the Society, such information as was at his disposal. It is to him that I am indebted for the following copy of the most recent communication addressed by M. Denayrouze to the French Academy of Science:—

To the Permanent Secretary,
Académie des Sciences.

Although the invention of Monsieur Paul Jablochhoff has been continually advancing ever since the first communication I had the honour of addressing to the Académie, I thought it becoming to wait before again calling its attention to the experiments until a further application had proved publicly and practically—

1st. That the candle could advantageously take the place of the clockwork;

2nd. That it was possible by this process to get several lights from a single source of electricity.

We have just put these two points out of the field of discussion,

by lighting up one of the principal warehouses in the Louvre with a number of lights during the whole of last week.

I think I shall be able, after this public proof of the principle submitted to the Académie, to make known to the Members some new and far more important discoveries which M. Jablochhoff has made in these experiments during the last few months in the factory belonging to the Company which I manage.

After our first experiments with the candle we recognised the fact, that, if we obtained a light of longer duration than with the regulator, and we succeeded at the same time in producing several lights, this two-fold result was due to the action of the current on the insulator placed between the two carbons, that the voltaic arc in fact by fusing this substance made a much easier passage for the current than when it was in a solid state.

Experience proves that by giving the current from the machine a certain intensity the distance which it could pass through this sort of liquid conductor became sufficiently great to allow us to set up a comparatively great number of lights; but there may be arranged as many as eight candles to burn at one time in the circuit of a single machine of the commonest kind with alternating currents.

From that M. Jablochhoff was led to try the effect of the sparks produced by a current of great intensity on refractory bodies.

He introduced into the centre circuit of the machine the primary wires of a series of induction coils, and sent the electric current from the induced current on to a slip of kaolin placed between the two ends of the outside wire of each coil. We then saw that, although the current had not sufficient intensity to cause the interposed kaolin to melt and consume, it nevertheless heated it to a white-heat.

The current is first sent through a sort of priming of greater conducting power along the edge of the slip of kaolin. The part of the slip which is heated in this way forms a conducting line of great resistance, which becomes white-hot, and throws out a beautiful light when a current of great intensity is passed through it. A certain consumption of the kaolin takes place throughout the whole extent, but the consumption is small. The slip consumes at the rate of about a millimetre per hour throughout its whole extent.

The result thus obtained between the two ends of the wire of the

coil is a splendid band of light, which reaches to a greater length than the induction spark would if discharged in air alone; but this luminous band, unlike the induction spark, which gives no light, gives out a permanent light, softer and steadier, than any other light in existence, including the electric light.

As to its power, that only depends on the number of the spirals and the diameter of the wire of the coils used.

As a great number of coils can be placed in a circuit, and as the slip of kaolin of convenient size placed on the coil can be divided into several sections, each one emitting light, the complete divisibility of the electric light is obtained. Fifty lights can easily be obtained from a single machine of the ordinary kind.

In our experiments we used coils of different sizes, and the intensity of the light was in proportion to them, varying with the diameter of the coil.

We arranged the intensities of the different lights so as to have a graduated series of luminous bands, the weakest of which gave a light equal to about two gaslights, and the strongest equalling about fifteen.

By using alternating currents the interrupter and condenser of the coils are not required. The whole system of distribution of the currents is in fact reduced to a central artery represented by the series of primary wires of the coils, from which branch out as many distinct conductors, which are placed on the secondary coils in the circuits. Each light, therefore, is perfectly independent of the others, and can be lighted or extinguished separately. The distribution of electricity over a building becomes in this way similar to the gas and water supplies, and in the special factory which we are constructing the large rooms are lighted with candles and the offices and passages by luminous bands.

The lighting apparatus of small places are most strikingly simple, indeed they are nothing more than a pair of clips holding a slip of porcelain, which, if a centimetre wide, will burn a whole night.

In short, the discoveries of M. Jablochhoff now made known, and of which I do not fear to undertake to supply at once the clearest and most practical proof, are as follows:—

Complete divisibility of the electric light.

Perfect steadiness of the divided light.

Means of distributing large or small lights of any intensity, and at any point of a place to be lighted.

Suppression of carbons for small and medium lights.

I may add, that, in accordance with our invariable rule of procedure, we are only communicating to the Académie results practically obtained without bringing before them those which are only experiments.

L. DENAYROUZE,

Formerly Student of the Ecole Polytechnique,
Prizeman of the Institute ;

Member of the Jury of the Exhibition of 1878.

Monday, 16th April, 1877.

As is no doubt known to many Members far better than to myself, attempts have from time to time been made to subject the electric light to general lighting purposes, but hitherto these attempts have not been successful; the electric light, where employed, having been for the main part confined to lighthouses and other special purposes. The ordinary arrangement of the electric lamp is well known; the carbon points from which the light is obtained are arranged vertically, the one above the other, and the distance at which it is necessary to keep them in order to produce the maximum of light is regulated by a train of wheels and guided by an electro-magnet, assisted, occasionally, by the hand of the

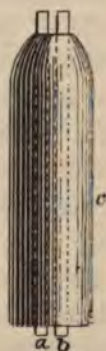

Fig. 1.

operator. M. Jablochhoff dispenses with this arrangement entirely. He places his electrodes side by side and separates them by an insulating compound. As originally designed, the carbons *a*, *b* (fig. 1), some four inches in length and one-quarter of an inch square, were embedded in an insulating substance *c*; the carbon slips being also separated from each other some three-sixteenths of an inch; the whole being moulded into the shape of a candle. In order to facilitate the early action of the current a small piece of carbon, about the size of the lead of an ordinary lead pencil, was placed across the top of the electrodes. With candles of this description, one of which is on the table for your inspection, a series of experiments were carried out at Chatham some time since by order of the War Office, the experiments being conducted by a Committee of Royal Engineers. It is stated that the power then obtained was some fifty per cent. greater than that obtained previously from the recognised electric light.

Since then M. Jablochhoff has twice modified this arrangement, each modification being attended with success beyond that obtained by the preceding. His first proceeding was to divest the carbons of their outer covering, leaving nothing but the carbon slips *a*, *b* (fig. 2), and the intervening substance kaolin *c*. It was with this form of candle that the experiments in the Louvre were carried out. Each carbon is fixed in a small brass tube *d*, *e*, the lower portions of which are left vacant, so that they may fit over two metal pins, attached to which are the secondary wires of the coil. These tubes are insulated the one from the other, the whole being bound together by a band of insulating material *f*. One of these candles is also on the table for your inspection.

The latest modification embraces the removal of the carbons and the replacement of them by a carbon paste *a*, *b* (fig. 3), a sort of

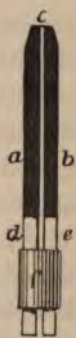

Fig. 2.

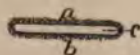

Fig. 3.

priming, the object of which is to reduce the resistance which the kaolin *c*, when cold, interposes to the passage of the current. With this arrangement, as M. Denayrouze explains, a splendid band of light, constant, soft, and steady is obtained.

Fig. 4 is a rough representation of the electrical arrangement so far as I have been able to gather without direct communication with M. Denayrouze.* A is the electromotor, a modification of the

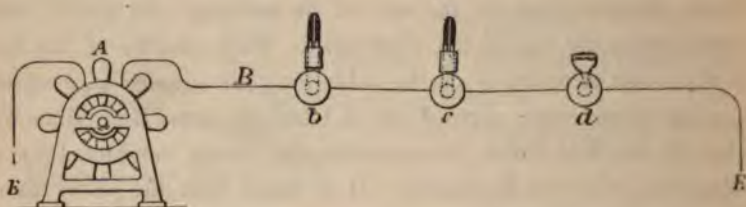

Fig. 4.

Gramme machine, sending its reversals according to the speed of the motive power, which it is perhaps needless to say is steam. B is the line wire, in circuit with which are the primary wires of the induction coils *b*, *c*, *d*, &c. corresponding to the number of lights required. The poles of the secondary wires of these induction coils are attached to the electrodes of the electric candle, as seen at *b*, *c*, or, where the luminous band of light is required, as in the manner shown at *d*. In the candle the action of the current first takes place at the top, promoted, as already explained, by the small piece of carbon placed there for that purpose. The kaolin then consumes slowly, and as it consumes so the light is removed lower down the candle, its consumption being precisely the same as that of an ordinary household candle. When the kaolin is consumed or

* At an exhibition of this form of light, which took place at the West India Docks on the 5th of June, the candles (fig. 2) were arranged in the main circuit. No induction coils were used; but the current from a secondary coil was employed to produce a light by means of kaolin alone, the current being first led across its edge by means of a piece of carbon, after which it burnt with a brilliancy second to that produced by the arrangement shown in fig. 2; the light in this case being, of course, independent of any other lights which might be produced from the agency of the same primary current. An "Alliance" machine was, on this occasion, made use of.

nearly so the light loses its white glow and assumes a red hue. It has then to be replaced by another. At the recent trial, referred to in the papers which I have read to you, the holders for these candles were arranged in pairs, only one candle being in use at a time. When one showed signs of having been consumed the wires were switched on to the other, and then that consumed replaced by a new one. An engine of 3-horse power was employed, from which 450 revolutions of the electromotor per minute were obtained. The light may be used naked or shaded.

So long as the electromotor A (fig. 4) is in motion, it is in the power of any one at *b*, *c*, or *d* to turn on the current, *i. e.* to complete the circuit of the secondary coil, and so obtain the necessary illuminating power. The whole arrangement assimilates very closely with our gas supply. Electromotors of the necessary power may be fixed at any spot, from which the primary wires will radiate, in the same manner as do the gas-mains from the gasometers; whilst the supply of the illuminating power may be controlled by switches or commutators, corresponding to the cocks and taps which govern the supply of the gas. In fact, given the illuminating power, we have at command a system less costly than coal-gas, less injurious to health, attended with less risk, and available at any point. I am informed by Mr. Applegarth that the cost of supplying a light equal to that obtained by gas will be certainly 50 per cent. less than gas. I need scarcely remark, the idea is one generally of large commercial importance, whilst to the Electrical Engineer it is of untold interest, opening up another large field for the application of that science, the utility and advantages of which are year by year becoming more unfolded.

I had hoped that Mr. Applegarth would have been able to afford you a practical illustration of this light; but, I regret to say, although in every way desirous to do so, the motive power was not at his command. Arrangements are, however, being made for lighting up a portion of the East and West India Docks, and I am commissioned to say that Mr. Applegarth will be delighted to have the presence of any Member of the Society on the occasion, and to place at his disposal every information in his power.

In conclusion, I have to ask you to receive the description which

I have laid before you with that caution which should accompany communications unattended by practical illustration. The impression that it is a subject which will command general public attention, and prove of interest to all associated with electrical science, must plead my excuse for intruding upon you a description so very general in character.

Mr. LANGDON at the conclusion of his paper said:—Since that which I have read was written, Mr. Applegarth has sent me a communication from M. Denayrouze to be read before this Society. I have, however, anticipated him, I believe, in all the points except two or three, which I will now read.

[The communication referred to is here reproduced in full.]

Mr. Applegarth, London.

Paper to be submitted to THE SOCIETY OF TELEGRAPH ENGINEERS.
GENTLEMEN,

I beg to submit most respectfully to your notice the important results obtained by M. Paul Jablochhoff during the experiments he made with the electric light, in the workshops of the Company of which I am the manager, during the past few months.

These results may be summed up under two heads.

1st. The suppression of the clockwork regulators in use up to the present time.

2nd. The means of dividing up the electric light indefinitely.

According as the light we desire to produce is to be composed of a few lights of great intensity, or of a greater number but of less intensity, so are the means we use very different. I will now describe the two different kinds of light.

I. The Electric Candle.

The electric lights of great intensity are obtained by means of a sort of candle, formed of two round carbon rods placed side by side, with an insulator between them. The lower end of each of these carbons is encased in a brass tube; which arrangement allows the carbons to be held firmly in a candlestick for the pur-

pose. A binding embedded in a solid paste prevents the carbons from coming asunder.

We may here state that a great number of mineral substances, and even some organic substances, may be used as insulators for these candles. The diameter of the carbons varies with the number of lights produced from the current, and also with the intensity of the current.

In the public experiments which have been, and are still being, made in one of the halls of the great warehouses at the Louvre, the carbons used are four millimètres in diameter, and the insulator between them is a slip of porcelain clay three millimètres thick.

To insure an equal consumption in length of the two carbons, it is necessary, when the electric machine used gives a constant and direct current, that the positive carbon be twice as thick as the negative carbon. With a magneto-electric machine reversing the currents, the carbons used are both of the same thickness, because they consume equally.

The Production of Light.

The voltaic arc is situated between the tips of the two carbons. As they consume slowly in the atmosphere, the slip of porcelain placed between them becomes hot and melts, and, becoming volatile, it renders the space between the carbons more conductive than it is in the ordinary clockwork arrangement. Moreover, the porcelain clay, which is an insulator in its solid state and cold, becomes a conductor when it melts, so that the candles may be extinguished by cutting off the current, and relighted by letting it through them again, if the porcelain has not been allowed to cool sufficiently to render it an insulator.

In this way we have been able, by joining the circuit, to re-light the candles 7 seconds after they had been extinguished by breaking the circuit.

This greater conductivity of the voltaic arc and the fused porcelain allows several lights to be made in a single circuit, a thing which has been hitherto unattainable. With a machine of the ordinary kind worked with steam power, eight separate lights can be pro-

duced, the intensity of the sum of their light equalling the light of about 300 Carcel gasburners.

Automatic Lighting.

As soon as the circuit is made the candle lights itself by means of a very simple arrangement. A little bit of graphite, 1 millimètre thick and 10 millimètres long, is laid across the ends of the carbons and held in its place with a little slip of asbestos paper. The current passes through this conductor, heating and volatilizing it, and the light is produced at once.

By this system we produce a light which is soft, steady, and brilliantly white, an inestimable advantage in all establishments where goods are selected and sampled by their colour.

The light can be coloured when required by mixing with the porcelain clay any colouring matter desired.

Public experiments have proved that what is so far described in this paper are facts beyond discussion, and may be summed up as follows:—

1st. That the candle is an improvement on the system of clockwork regulators.

2nd. That several lights can be produced from a single electric current.

II. The Production of Small and Medium Lights.

I am able to announce, in addition to the above, a discovery of M. Jablochhoff, which is of far greater importance.

In the very first trials we made with the candle we came to the conclusion that, if we got a more certain light with our candle than with the regulating clockwork, and at the same time we succeeded in producing several lights from one current, this twofold advantage was due to the action of the current on the insulator placed between the two carbons. The voltaic arc, in melting this insulating substance, made between the two carbon points a much easier passage for the current than when the insulator was in a solid state.

Experience showed, that, by giving the current from the machine *a certain force*, the distance which the current could get over

through this liquid conductor was great enough to produce a comparatively large number of lights. In this way we obtained as many as eight lights from candles placed on the circuit of one machine of the commonest size with reversing currents.

M. Jablochhoff afterwards tried the effects of the light produced by a current of great force on refractory bodies. He placed inside the circuit of the machine the inside wire of a series of induction coils, and sent the sparks from the induced current on to a slip of porcelain held between the two ends of the outside wire of each coil. We then saw that, although the current had not sufficient intensity to melt the porcelain which intervened, still it heated it to a white heat.

The current is first passed through a sort of priming of greater conductivity, placed along the edge of the slip of porcelain. The portion of the porcelain heated in this way forms a conducting line of very great resistance, which becomes white hot when a current is sent through it and emits a beautiful light. There is a certain consumption of the porcelain, but it is not very considerable, being about a millimètre per hour.

The result obtained in this way between the two ends of the wire of the coil is a splendid band of light, which may attain to a much greater length than the induction spark generally obtained from the coil used; but, unlike the induction spark, which gives no light, this luminous band is a light, constant, soft, and steadier than any other light in existence, the electric light included.

With respect to its power, that depends on the number of turns and the diameter of the wire used in the coils.

As many coils may be placed on the circuit, and as each coil may have a separate slip of porcelain, the means of thoroughly dividing up the electric light is obtained. We can easily produce fifty lights with one machine of common size.

In our experiments we used coils of different sizes, and the intensity of the light from each varied with the size of the coil. We arranged the intensities of our lights so as to have a graduated series, and the weakest shed a glimmer equal to the light of one or two gaslights, and the strongest equal to about fifteen gaslights.

By using reversing currents, the interrupter and the condenser of the coils become unnecessary. Thus the whole system of distribution of currents is reduced to a central artery, formed of the series of internal wires of the reel, from which branch out so many distinct conductors as there are coils placed in the circuit; therefore each light is perfectly independent of the others, and can be extinguished or lighted separately. The distribution of electricity over a building to be lighted up, therefore, becomes exactly like the gas arrangements. In the factory which we are specially building for this business the large rooms will be lighted with candles, and the offices and passages with bands of light.

The appliances for lighting-up small rooms are wonderfully simple, as they consist merely of a pair of clips holding a slip of porcelain. A piece of porcelain 10 millimetres wide will burn a whole night long.

In short, the discoveries which M. Jablochhoff has now made known, and of which I undertake to give the most conclusive practical proofs, are as follows:—

The means of completely dividing up the electric light.

Perfect certainty of the light so divided.

The means of distributing lights of different intensities, great, medium, and small, over the different parts of a building.

The suppression of carbons for small and medium lights.

Price of the light.—As the present paper deals merely with the description of the apparatus, there is no necessity for speaking of the cost of this light. Ultimately I shall give some information as to the value of this light from a commercial point of view, and prove that it is very much cheaper than gas.

(Signed) L. DENAYROUZE,

Former Student of the Polytechnique School, and Prizeman
of the Institute;

Member of the Jury of Admission to the Exhibition of 1878.

Paris, 5th May, 1877.

The PRESIDENT: Mr. Langdon has brought before us a matter not only of much interest, but of considerable importance. I am myself acquainted with the experiments which were made at Chatham some months ago with this new form of electric light, and I am able to say they were of a promising nature, although certain defects existed in the arrangement of carbons which required to be overcome. That these have been overcome there can be little doubt after what we have heard to-night from Mr. Langdon with reference to the very successful experiments made in Paris. There are several gentlemen present who have had experience in the application of electric light who may be able to give us some information with reference to the possible advantages and possible defects of this particular system.

Mr. LADD: Some few years ago, when trying large coils with my Dynamo-Magneto Electric Machine, giving reverse currents, I found (without the condenser) the discharge obtained from the secondary coil was more like the arc of a battery than anything I had ever seen before, and I have no doubt it would have given light, but that not being my object, I did not try it.

Mr. APPELGARTH: I think Mr. Langdon has made such good use of the information he has obtained that he has left very little for me to add, unless it is to give a short description of what I saw of the experiments with this light in Paris, which may be of some little interest to the meeting. I regard this as a great step in the science of electricity, but what may be said in reference to it on that head I leave in the hands of chemists and those who have given attention to it, and I will confine myself to the consideration of the subject as one of public utility. The place in which the experiment was made was about twice the width and twice the length of this room, and was ordinarily lighted up by about 100 gas jets of large size, each carrying a glass globe about a foot in diameter. The chandeliers held groups of nine or ten lights, each suspended by a long rod from the ceiling. At the proper time for lighting up, the gas burners were lighted as usual, after which instructions were given to light up the electric candles. In about five minutes there was an appearance of a sort of daylight above the gaslight, the latter being of a dirty brown colour. The gas

was then extinguished, and the place was lighted as if by daylight. I confess, after the first experiment I saw at Chatham, I was amazed. I expected to see a flickering effect, but, on the contrary, the light was steady, and had all the appearance of daylight. An opal globe was placed on each end of two brass rods which represented a double-ended gas branch or bracket. On looking about for the mechanical means by which this light was produced I saw a 3-horse engine, which was driving the electromotor, and the coil attached thereto went round much after the fashion of a gas tube fixed in a room, and at intervals were the six lights. The thing is altogether so simple, by dispensing with the clockwork which is usual in ordinary electric lights, that it may be regarded as a practically complete adaptation of this form of light to the general purposes of lighting. In a few weeks' time I hope myself to make a trial of this light at the East and West India Docks, which I have every reason to believe will be followed by the practical adoption of it on a very large scale. I have every reason to believe this will be the case from the great number of communications on the subject which I have received, to many of which, I am sorry to say, I have not been able to reply. I regard its general adoption as a matter of certainty.

The PRESIDENT: In asking you to return thanks to our Acting-Secretary for favouring us with this communication, it is my duty to announce to you that this is the last meeting of this Session of the Society, and that we meet again for the reading and discussion of papers on 14th November next. At the commencement of the ensuing Session we are promised a paper of considerable interest on "earth currents," and it is hoped that Members of the Society, being aware of the fact that this subject is to be brought before them, will, during the recess, prepare themselves for an exhaustive discussion on one of the most important subjects that the telegraph engineer has to grapple with. Papers on other subjects are also promised—amongst them, the Telephone, and the systems of quadruplex and duplex telegraph working, on which we may expect to receive some important practical information on the return of Mr. Preece from America. Another paper will be on insulating materials. On all these matters it is most desirable that a thorough

discussion should take place. It is my duty as well as pleasure to point out the characters of the subjects which we hope we may have to discuss in the course of the ensuing Session.

The vote of thanks to Mr. Langdon was unanimously passed.

The following candidates were balloted for and duly elected:—

FOREIGN MEMBERS :

Elisha Gray.

Thomas J. Larkin.

Professor Moses G. Farmer.

George A. Hamilton.

Geritt Smith.

MEMBER :

A. H. Irvine.

ASSOCIATES :

William Dennett.

Thomas Thompson.

John Lea.

Thomas Thornhill Markham.

B. Mason.

Julius Ebel.

When the meeting adjourned for the recess.

ORIGINAL COMMUNICATIONS.

ABSTRACTS AND INFORMATION REGARDING SOUNDINGS TAKEN WITH SIR WILLIAM THOMSON'S APPARATUS ON THE WEST COAST OF SOUTH AMERICA.

BY MR. H. BENEST.

This paper is submitted to the Society of Telegraph Engineers in the belief that the matter contained therein may prove to be of interest to many, and probably useful to a few, of the Members.

In June, 1875, a cable steamer left Valparaiso *en route* for Callao, touching at and making examination of the several ports at which the shore ends of the different sections of the West Coast of America cables were to be landed.

Soundings were taken over the ground that the heavy types of cable would be laid on, to a hundred fathoms' water off each port.

Some sixteen days had been occupied in making this inspection and taking the soundings necessary, when the cable ship arrived at Islay.

On June 21st, 1875, the undertaking of sounding, over the route which the first section of the west coast system was to follow, was proceeded with.

Three thousand fathoms of Horsfall's No. 22 B. W. G. steel-wire were wound on the drum to start with. The sinkers used were of the weight specified, and similar in design to those of Sir W. Thomson's pattern, except that an india-rubber valve was substituted for the ordinary "butterfly."

Means for facilitating operations were adopted as the work progressed. By means of an extra pulley on the auxiliary shaft, and a belt rigged from thence to one on the steam winch, much greater speed was attained, and consequently a deal of time saved, in the recovery of the wire.

Some difficulty was anticipated in preserving the wire while it

was being exposed unavoidably to the action of the sea-air and necessarily wet with salt water, so a portion of the alkaline solution in which the wire had been previously steeped was poured into the trough under the drum, the object in view being to keep the wire passing through it while reeling up; but this plan did not answer, inasmuch as the solution was splashed out, wetting the break-strap and reducing the friction, thereby causing the wire to overrun the sinker in descending.

On the failure of this plan the wire was caused to pass through some oiled waste while picking up, and the wire on the drum well "dosed" with ordinary engine oil during intervals of soundings.

The wire, a sufficient quantity of which was wound on the drum belonging to the apparatus, had been kept, in tanks constructed for the purpose, in a solution of the following proportions: viz.

Caustic soda . . .	3 oz.
Fresh water . . .	1 gallon.

The surplus wire, being wound on another drum and treated in like manner, was ready to replenish any loss that might occur from the drum in use on the machine.

In less than twelve hours from the commencement of the work ten casts had been taken, the maximum depth attained being 1,122 fathoms, minimum 425, amounting in the aggregate to over 5,600 fathoms. Distance run and ground sounded over, about 60 miles.

Two weights were lost with nearly 500 fathoms wire. On one occasion the sinker was supposed to have fouled on a rocky bottom, the wire parting at some depth below the surface without any undue strain being put on from the ship.

This, the first day's experience with the apparatus, certainly proved that it had deserved the merits which had hitherto been claimed for it.

During the following day, June 22nd, 1875, eleven soundings were taken, the maximum depth attained 958 fathoms, minimum 250 fathoms; aggregate number of fathoms nearly 6,000. Distance made and ground sounded, over 104 miles. A strong south-east wind was experienced during the night, rendering operations some-

what more difficult. It was found best, under these conditions, to bring the ship up head to wind and sea, keeping the engines going over the centre to enable her to keep steerage-way. An approximate correction applied for the angle of the wire would give the depth sufficiently correct for all practical purposes; but invariably it was the case that by the time the weight reached the bottom the wire would be plumb, the vessel just "holding her own" against wind and sea.

No wire nor weights were lost during this day's work, and at nearly midnight the task was relinquished until daylight should permit of fresh bearings of the land being observed and a new departure taken.

On June 23rd but seven casts were taken, owing to a dense mist overhanging the land, and, even when clearing a bit, some doubts were held as to the correctness of the bearings. Maximum depth attained 730 fathoms, minimum 119; aggregate number of fathoms, 2,500; distance made and ground sounded over, about 40 miles. Lost 329 fathoms of wire and one weight, owing to wire fouling on the drum.

At about 8 o'clock in the evening, the exact whereabouts of the ship being somewhat doubtful, she was brought to anchor some five miles from the shore in 88 fathoms—mud, with a heavy grapnel and 150 fathoms of 6 × 6 steel wire and manilla grapnel rope.

The next day, June 24th, better work was done, the conditions of the weather being more favourable. Ten casts were taken,—maximum depth attained 715 fathoms, minimum 143 fathoms; aggregate number nearly 4,000 fathoms; distance made, &c., 100 miles. Lost one weight and 126 fathoms of wire; cause in doubt. Anchored, as on the previous night, in 83 fathoms, soft mud.

On June 25th twelve casts were taken, making an aggregate of nearly 5,000 fathoms, and distance made 85 miles. Moderate weather was experienced, with a slight swell. Anchored as before at night.

June 26th. Twelve soundings, as yesterday, making an aggregate of over 5,000 fathoms, and distance 105 miles. Anchored again as before.

June 27th. But six casts were taken, giving a total of 2,100 fathoms; distance made 80 miles.

June 28th. Soundings were continued all night up to noon, when eight more casts had been taken—in all 535 fathoms. Distance made, &c., 40 miles.

This day brought the sounding operations on the first section to a successful issue. A very heavy swell, increasing as the water shoaled, rendered the work both difficult and unpleasant.

A summary of the foregoing abstracts shows the distance made to have been over 600 miles, going on an average nearly 90 miles a day.

Seventy-six soundings were taken, representing an aggregate of 30,466 fathoms, or an average of eleven casts and an aggregate of 4,352 fathoms each day.

In all, four sinkers were lost with 942 fathoms wire.

Comparisons are proverbially odious, but such may be admitted here to show the great superiority of the method of wire-sounding over that of rope, and in making this comparison it need not detract in the least from the credit due to the officers of the Peruvian navy for the able manner in which they carried on the work of sounding over the same section, previous to the advent of the cable ships with their improved and scientific appliances.

A Peruvian Government steamer left Callao on 31st May, 1875, and arrived at Ylo, a port some 50 miles south of Islay, on the 15th June. One hundred and twenty casts had been taken during this period, the maximum depth attained being 618 fathoms, amounting, in the aggregate, to nearly 18,000 fathoms. Four casts, giving a total of 2,149 fathoms, were recorded—no bottom.

This would give (say) eight casts a day, equal to about 1,200 fathoms in the aggregate, and about 40 miles of ground covered, against eleven casts, equal to an aggregate of nearly 4,500 fathoms and 90 miles distance made when using the wire. Much greater rapidity was afterwards attained with the Thomson apparatus, as will be shown, being of course the result of practice.

The absence of further records of the time occupied by the Peruvian steamer in completing her survey of the bottom as far as the Bolivian frontier, effectually prevents further information being given on the subject; however, a brief description of the ship and the nature of her appliances for sounding may be of interest.

Tonnage, about 1,200 tons net; horse-power about 240 nominal, propelled by paddles; she was used as a dispatch vessel, and was chosen and commissioned for sounding, as being the most suitable ship available in Callao at the time.

It is true that the sounding-gear on board this vessel was unavoidably of the most ordinary description. The only line to be procured was 21-thread Manilla. Of sinkers there were a large assortment, big leads and little leads, fat leads and thin leads, short and long; many of these were "made up" into bundles of a weight sufficient to carry the light buoyant line to the bottom in more than ordinary depths.

There was no drum, merely a shear-leg with a block "rigged up" at the stern of the ship, the rope being sometimes hauled up after a cast in "man-o'-war" fashion of "stamp and go," and in depths of 500 fathoms or more taken to the steam winch, the barrel of which had been increased in diameter by having stout wooden battens placed thereon to quicken the process of picking up.

Of indicators there were two kinds, Massey's and Walker's, the preference being given to the latter by Captain Portal, the officer in charge.

The manner in which such an amount of work was done with so few facilities reflects great credit on those who were engaged in the work.

On the completion of the Chorillos-Mollendo cable, it was deemed expedient to supplement the soundings already taken by the Peruvian steamer between the last-named port and Arica with another series, to be taken with the wire apparatus; on this service one of the cable steamers was dispatched, having a few extra picked men on board accustomed to the mode of working the apparatus.

She left Mollendo at 7 P.M. on the 21st July, 1875, for Arica, and returned at 8 P.M. on the 23rd, having taken 30 casts amounting in the aggregate to over 9,000 fathoms, maximum depth attained 435 fathoms, distance made nearly 280 miles. Time occupied 37 hours.

No sinkers nor any wire lost.

On the 28th July the same ship was dispatched from Arica to take soundings between that port and Iquique; she returned to Arica at 6.50 P.M. on the 30th July, having taken 25 casts, reach-

ing an aggregate of over 9,500 fathoms, distance made about 260 miles. Time 52 hours.

324 fathoms wire and one sinker were lost.

On the Mollendo-Arica section it will have been seen that the cable steamer left Mollendo at 7 P.M.; no soundings were taken that night, as no reliable positions by bearings of the land were obtainable; therefore, a course was shaped for Arica. At daylight the next morning they "closed in" with the land, when bearings were taken, after which sounding was commenced, and so on, until the limit of her distance was reached, when "about ship," and a course was "shaped" for the position of first cast taken, sounding commencing towards Mollendo.

On the Arica-Iquique section the same plan was followed, excepting that, as the vessel left earlier, soundings were taken while correct bearings could be observed, and the vessel then kept on for Iquique, which was reached at daybreak, when the same course was pursued as before.

On the 19th August the same vessel left Iquique homeward-bound, taking a careful set of soundings as far as Caldera; 4 days 14 hours were occupied in this work, some 500 miles of ground covered, and 60 casts taken, showing an aggregate of 26,500 fathoms. 1,260 fathoms was the maximum depth attained.

So "steep-to" is the coast on this section that over 1,000 fathoms were found five miles from the shore.

This completed the examination of depths required, and there can be no doubt that the speed with which the sounding operations were accomplished materially assisted in furthering the work and reducing the expenses of the expedition.

500 fathoms wire and two sinkers were lost on sounding over the last section.

Propos of flying soundings, such were successfully taken while paying-out cable in depths varying from 100 to 600 fathoms, without reducing the speed of the ship, which averaged five knots per hour.

The wire and sinker were nearly always recovered, except in depths of over 700 fathoms.

In addition to the flying soundings taken from the "paying-out"

ship, the accompanying vessel was engaged in sounding over any doubtful ground, and signalling results to the former.

Summary.

Exclusive of flying soundings the total number	
of casts taken were	201
Amounting in the aggregate to	76,500 fathoms
Distance over the ground about	1,400 miles
Time occupied	15 days 4 hours
Number of sinkers lost	7
Do. fathoms of wire lost	1,766

Prior to the arrival out of the "Dacia" last year with the cable requisite for the extension to Valparaiso, a Chilean Government steamer was ordered to take a series of soundings between Valparaiso and Caldera.

The appliances available were, as in the case of the Peruvian steamer, of the most ordinary description, consisting of a wood drum about 5 feet broad and some 3 feet 6 inches diameter (which by the way cost £16), on which were wound 2,000 fathoms of ordinary deep-sea lead-line; this latter had been left on the coast by the first expedition. A couple of Massey's patent leads, the only available ones in Valparaiso, were procured at an exorbitant price, and, with some additional sinkers to carry line to bottom in more than ordinary depths, the vessel was despatched.

Ten days were occupied in doing this work. The number of casts taken were 52, making an aggregate of over 24,000 fathoms, the maximum depth attained being 731 fathoms. The distance sounded over about 450 miles.

Out of the above soundings, eight were recorded no bottom in depths varying from 610 to 880 fathoms.

When going over the same ground afterwards and sounding with the wire at some of the indicated positions the depths recorded were found to be as nearly correct as could be expected considering the rough method which had been employed for obtaining them, showing that great care had been taken in the direction and management of the work.

The "Dacia" left Valparaiso on the 22nd August for Caldera,

touching at Coquimbo; 38 soundings were taken, making a total of nearly 15,000 fathoms; maximum depth was 1,085 fathoms, and distance sounded over about 450 miles; the time occupied in sounding being 2 days 13 hours.

A comparison in this case will render it apparent that sounding work can be done with the wire apparatus in something less than one-third the time occupied by the rope and heavy lead method.

A few abstracts from the sounding book will show the time occupied in taking casts in 1,000 fathoms, or thereabouts: viz.—

		H.	M.	S.
No. 9 Sounding	Let go at	11	9	50
	Down		32	15
	Up		52	20
	M. S.			
1,122 fms. Time	42	30		
No. 11	Let go at	3	24	30
	Down		35	0
	Up		55	0
	M. S.			
830 fms. Time	30	30		
No. 4	Let go at	5	32	50
	Down		40	30
	Up		52	0
	M. S.			
730 fms. Time	19	10		
No. 12 Extension	Let go at	4	51	0
	Down		5	5 10
		M. S.		
1,040 fms. Time	14	10	in descending.	
No. 33	Let go at	10	1	30
	Down		22	0
		M. S.		
1,085 fms. Time	20	30	in descending.	

In view of what has been set forth in the foregoing remarks, and by way of making the comparisons therein contained more striking, a statement showing the relative cost of rope and wire-sounding gear are appended.

ROPE-SOUNDING APPLIANCES.

Ordinary deep sea lead line per 1,000 fms.	Drum, &c.	Leads each.	Connections per set.
£ s. d. 15 5 3	£ s. d. 2 10 0	£ s. d. From 3 15 0 to 6 0 0	s. 14

WIRE-SOUNDING APPLIANCES.

Wire per 1,000 fms.	Sir W. Thomson's apparatus complete.	Sinkers each.	Cod-line per 100 fms.	$\frac{1}{2}$ " iron rings each.	Caustic soda per lb.
£ s. d. 2 5 0	£ s. d. 30 0 0	s. 6	s. d. 2 9	d. 3	d. 1½

From the above we will deduce the cost of a complete outfit of each.

ROPE, &c.		£	s.	d.
Say 5,000 fms. Ordinary D.S. line, at £15 5s. per 1,000 fms.		76	5	0
25 sets Connections, at 14s. each		17	10	0
Drum, &c.		2	10	0
Leads—3—150, 2,000 and 3,000 fms. £3 15s. to £6 each		15	0	0
Total		£111	5	0

WIRE, &c.		£	s.	d.
Say 15,000 fms. Horsfall's wire, at £2 5s. per 1,000 fms.		33	15	0
Sir W. Thomson's apparatus, complete		30	0	0
20 Sinkers, at 6s. each		6	0	0
100 fms. Cod Line		0	2	9
20 $\frac{1}{2}$ -inch iron Rings, 3d. each		0	5	0
10lbs. Caustic Soda, at 1½d. lb.		0	1	3
100 Lead Weights for Brake, at 3½d. each		1	9	2
Total		£71	13	2

It will be seen that with 10,000 fms. more sounding (wire) line and seventeen more sinkers, with no increased risk of losing wire or weights, the total cost is nearly one-third less; adding to this great desideratum the many other advantages that have been shown of this over the more primitive method, certainly stamps it as the most practically useful sounding apparatus yet invented, and there is no doubt but that with some modifications it may be brought into use in the ordinary routine of navigation.

Independently of the saving in actual cost, it should be borne in mind that a most important item is represented by the saving effected in time and fuel on board a steamer engaged in this class of work.

Were the two systems equal in efficiency, the fact of having a greater quantity of material, and that at a much lower cost, would give the preference to the employment of the wire apparatus.

Subjoined are the results of a few tests taken for breaking-strain on some wire which had been in use, and kept immersed in the caustic soda solution for nearly two years:—

No.	Broke at	Elongation.	Remarks
1	196 lbs.	3%	Broke in middle of wire.
2	196 lbs.	3%	Do. do.
3	196 lbs.	3%	Do. do.
5	198 lbs.	3%	Do. do.

The original breaking-strain of the wire when delivered new rarely exceeded 200lbs.

In concluding these details and remarks, it will be well perhaps, as a comparison, to give some particulars of the soundings taken for two of the Atlantic Cables. This will convey a correct idea of the extent of work considered necessary for safely depositing at the bottom of the ocean such slender but important property as Submarine Cables.

The cables of 1865 and of 1869 (French) are selected as showing the greatest number of soundings, and where, as may be well under-

stood, neither trouble nor expense was spared in order to obtain the best possible knowledge of the nature and contour of the bottom.

Taking first the lines of 1865 cable between Valentia and Newfoundland, 57 soundings were taken over a distance of about 1,700 miles.

On the line of the French Atlantic between Brest and St. Pierre, 21 soundings were taken in shallow water on the French side, from 40 fms. to 110 fms. over a distance of about 300 miles, 43 soundings were taken in deep water, and into 124 fms. on the American side, over a distance of about 2,440 miles. Seven more were taken in depths under 100 fms., making in all 71 soundings over a total distance of about 2,800 miles.

On the West Coast of America cable expedition 239 soundings were taken with the Thomson apparatus and 221 by the two Government steamers before referred to, in all 460 soundings over a distance of nearly 1,700 miles. This number is exclusive of those soundings taken during the examination of landing-places, and of which mention has already been made.

From what has been set forth in this paper, it will be apparent that, with the Thomson machine for taking soundings, such a contingency as a cable being laid on doubtful ground need not occur. And it may reasonably be supposed that the so-called ordinary deep-sea lead line with hundred-weights of sinkers, and that clumsiest of all clumsy methods of determining the depth, a 3 × 3 buoy-rope and a five hundredweight mushroom, are contrivances of the past.

DESCRIPTION OF AN AUTOMATIC LOCKING SWITCH, AS DESIGNED AND APPLIED BY MESSRS. JAMIE- SON AND DEWAR TO MESSRS. ELLIOT'S SENDING KEYS.

This combined key and switch is intended for use on submarine cables, underground wires or land lines, with speaking galvanometers, Sir William Thomson's Recorder, or any other form of *telegraphic* instrument using the same style of notation.

The objects of this locking switch are to prevent telegraph clerks leaving their switches over for *sending* when they should be arranged

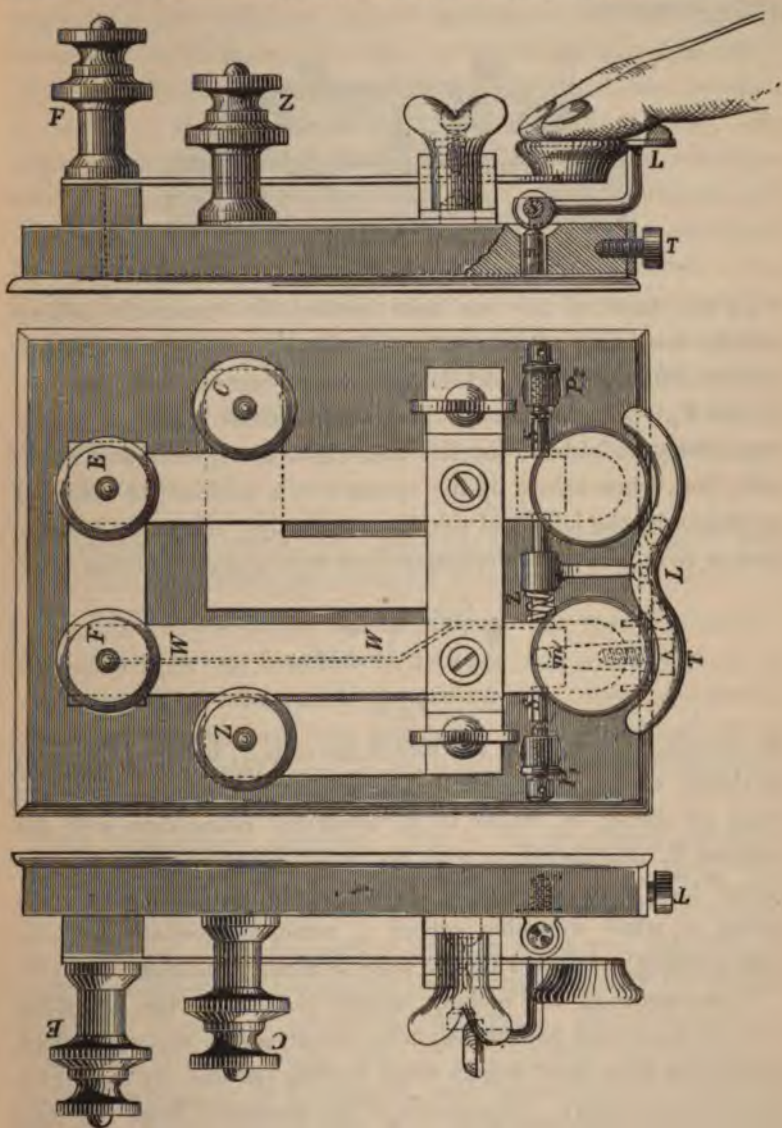

Fig. 1.

for *receiving*, or *vice versâ*, and to combine on the same ebonite base-plate the whole arrangement of sending-key and switch.

The sending-key arrangement is precisely the same as that manufactured by Messrs. Elliot for the Western Brazilian Telegraph Company.

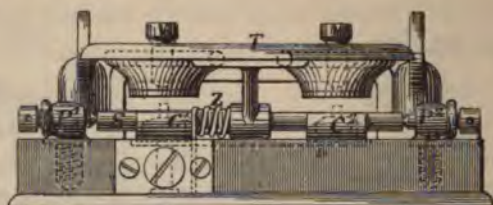

Fig. 2.

To this form of key has been applied the automatic locking switch, consisting of a rocking spindle S , passing underneath, both sending pedals supported by adjustable centres, with jam nuts P_1 and P_2 . Fixed to the spindle s are two cams c_1 and c_2 , placed respectively underneath the left and right hand, their size being such, that, when turned by the spring z to a position for *receiving* (as shown by the left-hand side elevation), they effectually lock the keys so as to prevent the operator from *sending* until he turns down

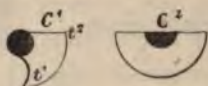

Fig. 3.

the switch. On turning the switch the cam c_1 , being of the form as shown above, makes contact at its lower corner t_1 with the point of spring m , which is in electrical connection with the terminal T , and, therefore, with the *sending* shunt and line. The corner t_1 of cam c_1 , when in a position for receiving, clears the spring m , while the other corner t_2 comes underneath the left-hand sending pedal, locking the same as already mentioned.

To the centre of the rocking spindle S is fixed the switching lever L , faced with polished ebonite, which serves as a convenient rest for the three front fingers when sending (as seen by the right-hand side elevation). On removal of the operator's hand the tension of the spring Z (which is coiled round the spindle S) turns the spindle carrying the lever and cams with it, thus automatically placing the key and speaking instrument in a position for receiving.

A permanent electrical connection exists between the end terminal F and the spindle S by means of the copper wire W, which is soldered at both ends, and carried underneath the sole-plate; in some cases the end attached to the spindle (S) is fixed to the centre of the switching lever L, where there is little travel, and in others to the end of the spring Z, or else a continuation of the same. The latter is perhaps the better plan. From this it will be seen that, when sending and using the recorder, the outgoing currents split at terminal F, between the resistance of the sending shunt and that of the recorder coil, &c., the greater part going direct to line by the former, and the smaller through the instrument coil (its resistance being the greater), producing what are termed the sending signals, which not only act as a detector to show that the circuit is all right, but prove a check on what may have been sent, and must correspond with the signals received and printed by the recorder at the other end.

ARRANGEMENT OF CONNECTIONS NECESSARY FOR CONNECTING IT WITH
SIR WM. THOMSON'S RECORDER OR SPEAKING GALVANOMETER.

1st. *Receiving with the Recorder.* Fig. 4. Currents coming from the cable split at terminal 4, between the resistance of the recorder coil and that of the receiving shunt (the part passing through the instrument coil producing the signals), both meeting again at terminal 3, pass to earth by terminal F, left-hand key, across the key-bridge, and along the right-hand key.

2nd. *Sending with Recorder.* Fig. 4. On depressing the right-hand pedal the copper pole of sending battery is put to earth, while the zinc is in connection with terminal F, where the current splits between the resistances of sending shunt and recorder coil with receiving shunt, the greater part going to line by the sending shunt, on account of its smaller resistance. The course of its passage is from F, along wire W, to spindle S, to cam c_1 , through contact m , to terminal T, and thence by lead to sending shunt, and through sending shunt to cable; while the smaller quantity passes to terminal 3, and there splits between the resistance of the receiving shunt and the instrument coil; both meet at terminal 1, and pass to line with the first portion. Exactly the

same thing takes place on depressing the left-hand key, only zinc is to earth and copper to line.

Receiving with the Galvanometer. Fig. 5. Currents coming from cable split at terminal 5, if a receiving shunt is used between the

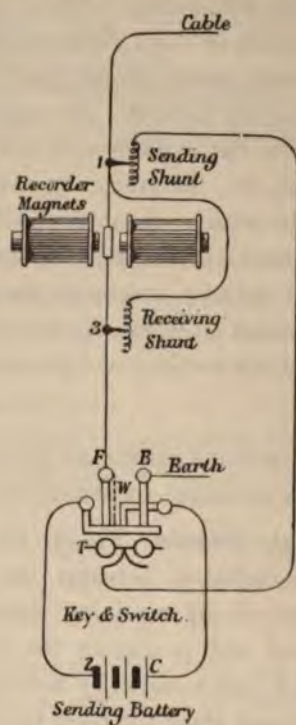

Fig. 4.

resistance of the shunt and galvanometer, but if no shunt is used the whole current arriving at terminal 5 passes through the galvanometer (causing signals) to terminal 6, thence to F, and to earth, the same way as has been described in the case of receiving with the recorder.

In using either recorder or mirror, no current can come from cable through the sending shunt when *receiving*, because the terminal T is freed by the contact *m*, not touching cam *c*₁.

Sending with the Galvanometer. Fig. 5. On depressing the *left-hand key* the zinc pole is placed in connection with earth and

copper with terminal F, from whence the whole of the current flows by wire W to spindle S, contact *m*, terminal T, and sending lead to line by terminal 5. No current (or at least only an infinitely small quantity—just enough to show that all is right)

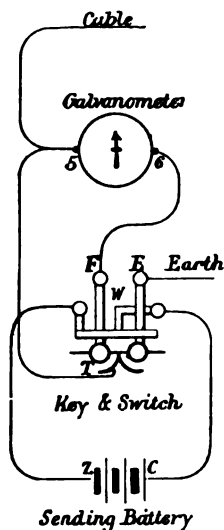

Fig. 5

passes through the galvanometer coil when sending, as the resistance of the galvanometer coil is so much larger than that of the sending lead.

The same takes place on depressing the right-hand key, only the copper pole is in connection with earth and zinc with line.

ANDREW JAMIESON.

UNIFILAR SUSPENSION.

An arrangement for supporting the silk fibre that carries, for example, a system of astatic needles in a galvanometer, would be pronounced a good one if it enabled the following operations to be quickly performed:—

1. Centering the fibre so that the magnets shall hang symmetrically with reference to the coils when the line passing through the centre of the coils is vertical.

2. Turning the fibre round its own axis to remove all tension when the needle points to zero.

3. Lowering the magnet so that the weight may be taken off the fibre when the galvanometer is moved, and raising it again without any risk of breaking the fibre.

4. Removing the system of astatic needles away from the galvanometer without disconnecting the fibre.

The system of suspension commonly employed in the Thomson's astatic galvanometers made by Messrs. Elliott Brothers, in which the silk fibre is attached to a vertical sliding pin, enables operations 2 and 4 to be performed fairly well, operation 3 only imperfectly, and operation 1 not at all. In addition there is considerable danger of torsion being accidentally put into the fibre in raising and lowering the magnets.

The plan followed by Messrs. Siemens, in which the fibre is wound round a horizontal pin, the supports of which are attached to a tube held inside a much larger tube by three horizontal screws, enables operation 1 to be performed, but with a little difficulty, operations 2 and 3 satisfactorily, and operation 4 not at all. In addition this system of the three screws is somewhat troublesome, and therefore expensive to make.

The following adaptation of the ball and socket joint occurred to

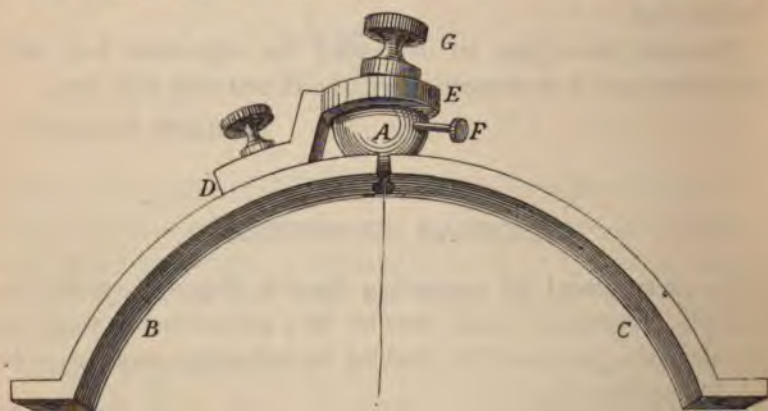

us during a conversation on this subject with Mr. Shaefer (formerly of the Japanese Imperial Telegraphs), and as it has in practice

been found very satisfactory we have thought it worthy of the notice of the Society of Telegraph Engineers.

A brass ball is allowed to rest in a spherical cavity made in the the upper surface of a metallic arc, and kept in position by a piece screwed to the arc. In this ball there is a vertical hole about $1\frac{1}{2}$ millimètres in diameter, except at the bottom, where it is made very fine. Into this hole is inserted the silk fibre which is fastened to the pin F, which passes through the ball and is made conical to prevent its slipping. G is a mill head-stopper, closing up the hole in the ball. This stopper serves as a handle with which to rotate the ball, and also by coming against the edges of the opening in the piece D E prevents the ball being rotated so far round a horizontal axis as to cut the fibre. When rotating the ball the screw fastening D E to B C is, of course, slightly loosened.

The way in which the fibre is raised or lowered, rotated round a vertical axis to remove torsion, placed in any vertical line within certain limits to centre it, is obvious, and it is also clear how the whole suspension can be removed from the instrument without disconnecting the fibre.

W. E. AYRTON.
JOHN PERRY.

The Imperial College of Engineering,
Tokai, Japan.

ON THE PRINCIPLES TO BE OBSERVED IN THE ERECTION OF WIRES OVER LONG SPANS.

I.—*Telegraph Wire.*

1. There are three kinds of wire at present in use for overland lines in India,* namely, the soft iron wire generally employed; homogeneous iron wire, which is stronger but less ductile; and stranded steel wire, which possesses still greater tensile strength. For wires of the same gauge, the homogeneous is about twice, and the stranded steel about three times, as strong as the soft iron.

2. In considering the value, from a mechanical point of view, of

* This paper was written with especial reference to Indian practice.

any wire for the purposes of overland telegraph construction, it is not with the absolute strength of the wire that we have to deal, but with a certain constant, which has been called the "modulus" of the wire. The physical meaning of the "modulus" will be readily understood from the following:—

3. Let T = the breaking strain of any wire; w = the weight of the unit length of the wire; and L = the length of itself it can just support without breaking. Then $\frac{T}{w} = L$ = "modulus": an absolute length, which is constant for any of the same kind and quality of wire, and whose numerical value simply depends on the unit of length adopted.

For instance, Johnson's soft iron wire, weighing about 600 lbs. per mile, breaks at a strain of about 2,000 lbs. Hence in this case:—

$$\text{Modulus} = L = \frac{T}{w} = \frac{2,000}{600} = 3\frac{1}{3} \text{ miles.}$$

But we have said that the homogeneous iron wire is about twice, and the stranded steel wire about three times as strong as the soft iron wire; and therefore the former would just carry $6\frac{2}{3}$ miles, and the latter 10 miles, of itself without breaking.

Breaking modulus for soft iron wire	= $3\frac{1}{3}$ miles
" " homogeneous iron wire	= $6\frac{2}{3}$ "
" " stranded steel wire	= 10 "

4. In straining up the wire on a line, a factor of safety (z) is allowed, so that the working strain (t) is only a fraction of the breaking strain (T). Thus

$$t = \frac{T}{z}$$

And if we call l the working modulus

$$l = \frac{t}{w} = \frac{T}{z w} = \frac{L}{z}.$$

In India the factor of safety generally adopted is 4, so that the wire is strained to only one quarter of its breaking strain.

The following table exhibits the working moduli corresponding to different factors of safety:—

WORKING MODULUS IN FEET.

Factor of Safety.	Soft Iron.	Homogeneous Iron.	Steel Strand.
3	5,867	11,733	17,600
4	4,400	8,800	13,200
	3,520	7,040	10,560
6	2,933	5,867	8,800

II.—*Properties of the Catenary.*

If a perfectly flexible but inextensible wire of uniform material and size throughout its length be freely suspended from two points, it will, under the influence of gravity, fall into a curve which has been called the “catenary.” The properties of this curve cannot be investigated without recourse to the higher methods of analysis; but it may be noted that when the “dip” of the wire is small compared with the horizontal distance between the points of support, the form of the curve differs little from that of the “parabola,” which is treated of in all books on the conic sections or on elementary analytical geometry.

It will be assumed that the wire is perfectly flexible and inextensible.

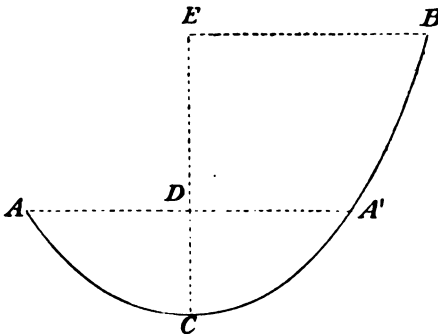

Fig. 1.

Let A and B (fig. 1) be the two points of the suspension and A C B the suspended wire.

Draw A D A' horizontally and C D E vertically.

The lowest point (the vertex) C of the curve falls nearer to the

lower point of support A, then to the higher point of the support B. When the two points of the support A and B are in the same level, then the vertex falls exactly in the middle between them.

The strain on the wire is least at the lowest point C, and gradually increases thence up to A on the one side, and up to B on the other side. The strain at A' on the same level with A is equal to the strain at A.

The strain at A is equal to the strain at C, plus the weight of a piece of the wire equal in length to C D, the vertical distance of A above C; similarly, the strain at B is equal to the strain at C, plus the weight of a piece of the wire equal in length to C E, the vertical distance of B above C.

In straining up wire we must bear this in mind, namely, that the wire is to be strained up until the strain at the higher point of support is equal to the working strain of the wire.

If we pull the wire A B tighter, the curve A C B will obviously flatten up; if on the other hand we slack out the wire, it will sag more and more between A and B, and the curve will deepen.

Let p be the strain on the wire at its lowest point C and w be the weight of the wire per unit of length. Now, if we put

$$C = \frac{p}{w}$$

then C is what geometers call "parameter" of the catenary. The "parameter" is the constant of the curve which defines its character—it flattens or it deepens—in fact, in order to find out all about the curve it is only necessary to know the positions of A and B in space and the "parameter" C.

The parameter C is obviously of only one dimension, namely in space; for p is "force" and w is " $\frac{\text{force}}{\text{space}}$ ", \therefore C is "space."

Let t be the strain on the wire at any other point A of the curve; and let us refer the curve to rectangular co-ordinates (the abscissa axis horizontal, the axis of ordinates vertical) taking the origin at a point situated at a distance = C vertically below the lowest point of the curve.

Then if y be the ordinate of the curve at A,

$$y = \frac{t}{w}$$

For

$$t = p + DC \times w$$

$$\therefore \frac{t}{w} = \frac{p}{w} + DC$$

$$= C + DC = y.$$

To simplify matters let us suppose that the points of support A and B are in the same level, and that the wire is pulled up to its working strain. Then t is the working strain of the wire, and $\frac{t}{w}$ is the working modulus of the wire, hence at the insulator

$$y \frac{t}{w} = l,$$

that is to say, the ordinate of the curve at the insulator is equal to the working modulus of the wire.

Since $t = y w$ at every point of the curve, it is easy to see that if instead of the wire being fixed at any two points A and B, it were balanced by the weight of portions of itself hanging over smooth pulleys at A and B, then the lengths of such balancing portions would obviously be such that their lower ends would be in the same horizontal line, namely the line we have taken as our abscissa axis.

Of all the possible curves that the wire A C B might form, the catenary is that whose centre of gravity is lowest—a property we can readily conceive as belonging to a curve described by a perfectly flexible wire influenced by the force of gravity alone. (The potential energy of the system is a minimum. See Thomson and Tait's "Natural Philosophy," page 575.)

III.—*Gilbert's Tables of the Catenary.*

When the project of erecting a suspension bridge across the Menai Straits was before the Parliamentary Commission, of which he was a member, it appeared to Sir David Gilbert, Vice-President of the Royal Society, that the "dip" allowed in the design was inadequate to insure the necessary degree of safety, and he therefore undertook an investigation of the properties of the

catenary, which he communicated to the Royal Society on March 9th 1826.

He added to his paper four tables, with two of which we are concerned here, and these are reprinted (from volume cxviii. of the "Philosophical Transactions") in the Appendix.

In the first of the tables calling $x =$ half span 100, and assuming arbitrary values varying from 2,000 to 70 for the parameter C , he has calculated the dip, length of wire in span, ordinate at insulator, and the angle formed by the wire with the vertical at the insulator.

In the second of the tables, calling $C =$ parameter 100, and assuming arbitrary values varying from 1 to 100, for x the half span, he has calculated the same particulars of the curve.

IV.—*The Main Span.*

The first point is to measure accurately the distance between the position chosen for the supports, and the difference of level, if any, between the points of support.

First Case.—The points of support are on the same level.

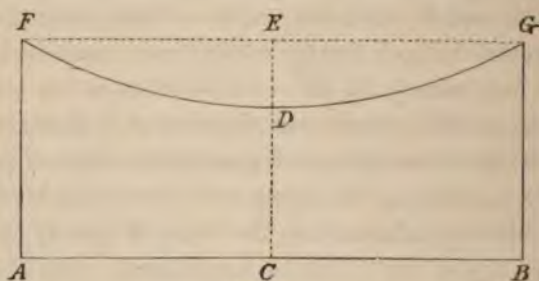

Fig. 2.

Our first datum is the length of the span $A B (= a) = 2 A C = 2 B C (= 2 x)$.

The least head-way $C D$ admissible at the lowest point (in this case the middle) of the span constitutes the second datum.

Knowing $A B$ and $C D$, and bearing in mind that the wire is always pulled up to some known fraction (generally $\frac{1}{4}$ in practice) of its breaking strain, so that a certain dip $E D (= d$, which can be found from Gilbert's Table No. 1) corresponds to the working

modulus ($= l$) and to the half AC ($= x$) we can find what height of support AF will be necessary.

The magnitude of the dip ED will obviously depend on the kind of wire employed. If soft iron wire be employed, the dip will be greatest; but it will be reduced if homogeneous iron wire be employed; and still more so if stranded steel wire be employed.

Since the construction and erection of lofty masts of sufficient strength and stability is necessarily very expensive, it is invariably more advantageous in the case of a span of any considerable length to use steel wire, so as to reduce to the utmost the height of the supports requisite.

Having calculated EC for the kind of wire to be employed, we know AF ($= DC + CE$).

Example.

A steel wire at quarter breaking strain is to be erected across a river 4,000 feet in span. The minimum headway admissible is 80 feet above flood-level of water. But the banks of the river are 65 feet above flood-level, and therefore a headway of only 15 feet will be necessary above the level of the banks.

First, to find the dip ($= d$). The working modulus of steel wire at $\frac{1}{4}$ breaking strain is 13,200 feet; this, therefore, is the ordinate of the curve at the insulator ($= l$). The span is 4,000 feet and therefore the half span ($= k$) is 2,000 feet.

Refer to Table I. calling $k = 100$, then $l = \frac{13200}{20} = 660$. Hence

$$d = \frac{7.590}{19.762} + 0.238 + 7.59 = 7.681 = 7.681 + 20 = 153.6 \text{ feet.}$$

The height of support necessary above the bank is therefore $153.6 + 15 = 168.6$ feet = say, to allow for contingencies, 170 feet.

Second case. The points of support are at different levels.

In this case the lowest point D of the wire F, D, G no longer falls in the middle of the span AB, but is situated nearer to the lower point of support F than to the higher point of support G.

The first point then is to determine the position of the vertex D of the catenary. Continue the catenary from F to G' . Draw $G H G'$ and $K' F E F' K$ horizontally and $B K G$, $A' F'$, $C D E H$, $A F$ and $B' K' G'$ vertically.

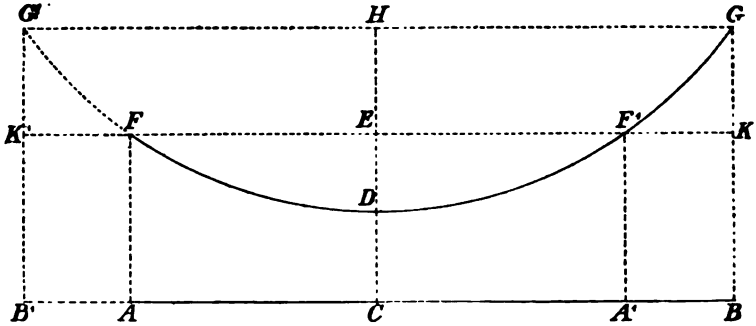

Fig. 3.

Let difference of levels between the points of support F and $G = G K = G' K'$ be denoted by b .

The wire will be pulled up so that it will be at its working strain at the higher point of support G (when the strain is greatest), hence the ordinate (y) of the curve at G will = l , the working modulus of the wire; and the ordinate (y') at F obviously = $(l - b)$.

If d denote the dip of the wire $D E$ below the lower point of support F , $(b + d)$ will be the dip below the higher point of support G ; and the parameter of the catenary C is = $\{l - (b + d)\}$.

Now we may regard $A C = C A' = X'$ as the half span of the catenary F, D, F' ; and $B C = C B' = X''$ as the half span of the catenary G, D, G' ; the two cantenaries having a common parameter C .

Our data are

$$x' + x'' = a$$

$$y'' = l$$

and

$$y' = l - b$$

Now, we note that the maximum value C can possibly have is

$C = y' = l - b$, as then the lowest point of the wire would be just resting on the lower point of support F.

The best way of solving the problem is as follows:—

Assume some approximate value of C, call this 100, and express y' and y'' in terms of the same unit. Then refer to Gilbert's table No. II. and find x' and x'' . If $x' + x'' = a$, then we have assumed the value of C, and x' and x'' are known, but if x' and x'' do not = a , then we have assumed a wrong value for C, and we must try another one; and so on until we do find the correct value of C, x' and x'' . The approximate value of x' and thence of C can be found by means of one of the formula given in the Journal of the Society of Telegraph Engineers, vol. iv. pp. 423, 424.

Knowing x' , there will be no difficulty in finding the dip DE ($= d$).

When we know the dip DE for the kind of wire to be employed and the point where the lowest point D of the curve falls, we can ascertain what height of supports will be necessary in order to allow of the requisite amount of headway under the lowest point D of the wire.

In the case of a span over a navigable river, the minimum headway requisite will often depend on the point of the river over which the lowest point of the wire happens to fall, *i.e.*, whether over shoal or deep water. If for instance the navigable channel is close into the bank on the side of G, then obviously much lower supports will suffice than if the channel were directly under the wire at D. It must not be forgotten, however, that in many rivers the navigable channel shifts from one bank to the other in the course of years.

Example. A soft iron wire at quarter breaking strain ($l = 4400$ feet) is to be erected across a span of 4000 feet, with a difference of 400 feet between the levels of the two points of support.

In this case—

$$x' + x'' = 4000$$

$$y' = l - b = 4000$$

and

$$y'' = l = 4400$$

We note that the maximum value C can have is $l - b = 4000$ feet.

Assume $c = 3614$ feet. Calling $c = 100$, $l = \frac{4400}{36.14} = 121.749$

$$\text{and } l - b = \frac{4000}{36 \cdot 14} = 110 \cdot 680 = x' \times x''$$

Referring to Table II., corresponding to the ordinate 121·749, we find $x'' = 64 + \frac{56}{69} = 64 \cdot 8116$; and corresponding to the ordinate 110·680, we find $x' = 45 + \frac{383}{471} = 45 \cdot 8131$.

Thus, assuming $c = 3614$, we get

$$a = x' + x'' = 45 \cdot 8131 + 64 \cdot 8116 = 110 \cdot 6247 = 3998 \text{ feet,}$$

which agrees within 0·05 % with the true value of a .

We can get a closer approximation than this, however.

Assuming $c = 3613 \cdot 4$, and calling $c = 100$, we have $l =$

$$\frac{4400}{3613 \cdot 4} = 121 \cdot 769, \text{ and } l - b = \frac{4000}{3613 \cdot 4} = 110 \cdot 699. \text{ Whence we}$$

find from Table II., $x'' = 64 + \frac{5800}{6907} = 64 \cdot 840$ and $x' = 45 + \frac{402}{471} = 45 \cdot 854$.

$\therefore a = x' + x'' = 45 \cdot 854 + 64 \cdot 840 = 110 \cdot 694 = 3999 \cdot 8$ feet, which is within 0·005% of the true value of a .

Thus we have—

$$c = 3613 \cdot 4 \text{ feet.}$$

$$x' = 1637 \text{ feet.}$$

and

$$x'' = 2343 \text{ feet.}$$

The dip below the lower point of support is—

$$\begin{aligned} d &= (l - b) - c \\ &= 4000 - 3613 - 4 \\ &= 386 \cdot 6 \text{ feet.} \end{aligned}$$

V. *The Back Spans.*

We shall treat the subject of this paragraph under three heads, namely, the first, when a continuous wire of the same gauge and material, whether iron or steel, is employed for the main and back spans; the second, when a steel wire is employed for the main span, and an iron wire of equal strength with the span wire for the back spans; and lastly, the third, when a steel wire is employed for the main span, and an iron wire of greater strength than the *span* wire for the back spans.

Knowing the dips $L P$ and $F P'$, and the parameter of the catenary $K P F$, we can find the distances $B M$ and $M C$ from Table II.

Then, of course, we have $B C = B M + M C$.

An easy method of adjusting the tension on the wire is here suggested. Of course, the dip of the main span can be adjusted by marking the two masts on the same level at the proper distance below the points of support; and then, looking from the one mark across the span at the other mark adjust the strain until the bottom of the wire is on a level with the eye. Or, on the same principle, by viewing the bottom of the wire from the proper point through a telescope provided with a level.

The method here referred to is to erect at H vertically below the wire a post $H J$, equal in height to $B K$, and pull up the wire until it just touches the top of $H J$.

Of course, if the wire be not terminated on $B K$, but on a second post $A N$, then the strain can be adjusted by measuring the dip $R Q$ of the span $A B$.

The back span $B C$ should not be made excessively great, as this would unduly increase the pressure due to wind on the mast $C F$. A practical rule may be taken not to make $B C$ greater than $C D$ half the main span, and the height of the checkpost $B K$ should be adjusted accordingly.

2nd CASE. *The span wire of steel backed by iron wire of equal strength.*—We have seen that it is invariably advantageous to employ steel wire for the span. Not so, however, in the case of the back spans, except under exceptional circumstances. The dip of steel wire is relatively so small that on anything like level ground back spans of excessive length would be necessary (or excessively high supports would have to be employed) in order to admit of the wire being brought down from the mast to its normal level. Soft iron wire is, therefore, usually employed for the back spans. The stranded steel wire employed at present is three times as strong as the soft iron wire. If, therefore, a soft iron wire of the same gauge were joined to the steel wire, and the steel wire was strained to a quarter of its breaking strain, then the iron wire would be at three quarters of its breaking strain; but, if a soft iron wire, or wire

rope, three times as heavy (for equal lengths) as the steel wire be joined to it, then they will both be at a quarter of their breaking strains: but the dip of the iron wire will be three times as great as that the steel wire would have had under the same circumstances.

The calculations for the span remain the same as in the 1st Case, but in finding the parameter of the catenary $H P F$ from the expression $[l - (F T + L P)]$, we must remember to take l for soft iron wire (of which the back span consists).

It must be here noted that in this and the following case the value of l changes abruptly at the insulator. If, for instance, we have a steel wire main span with a back span of iron wire of the same strength, and the wire is pulled up to quarter breaking strain, then on the main span side of the insulator $l = 13200$ feet, but on the back span side of the insulator $l'' = 4400$ feet.

This will be readily understood from the following. Let w' be the weight per unit of length of the steel main span wire, and w'' be the weight per unit of length of the iron back span wire; then, the strain l being, of course, the same on both sides of the insulator, we have—

$$\begin{aligned} l' &= \frac{l}{w'} \\ \text{and} \quad l'' &= \frac{l}{w''} \\ \therefore \frac{l'}{l''} &= \frac{w''}{w'} \end{aligned}$$

In the above case, since $w'' = 3w'$,
 $\therefore l'' = \frac{1}{3} l'$

3rd CASE. *The span of steel backed by iron wire of greater strength.*—Sometimes in cramped positions it is necessary to bring the check-post in so near to the mast that there is some difficulty in getting the wire down to it. This difficulty is met by employing iron wire for the back spans so heavy as to be more than equal in strength to the steel wire of the span. If, for instance, the span wire is three times as strong as the iron wire, then we should employ iron wire more than three times, *i.e.*, 4, 5, 6, . . . times, heavier (for equal lengths) than the span wire.

Thus the span wire being pulled up to (say) one quarter of its breaking strain, the back spans will be at less than one quarter breaking strain, and the dip will be proportionately more than three times that which the steel wire would have had under the same circumstances.

The calculations remain the same as in the first case, but in finding the parameter of the catenary $K P F$ from the expression $l - (F T + L P)$, we must remember to give l its reduced value.

Very slack back spans are conducive to contacts; and may, therefore, become dangerous, unless some special precautions are taken—as by fanning the wires out to different checkposts.

In this instance the point of departure from our calculations regarding the back span must, of course, be the fixed distance $B C$, to which we are limited.

Suppose we are given the distance $B C$, and the height of the post $B K$, it is very easy to calculate what wire will be required for the back span. Let $L P$ be the dip we desire to allow in the back span below the top of the checkpost $B K$.

Our data are the span $B C$, the dip $L P$, and the dip $F P'$ (since we know the difference of levels $F T$).

Assume an approximate value for the parameter of the catenary $K P F$; call this 100, and express $L P$ and $F P$ in terms of the same unit. Then, from Table II. find $B N I (= x')$ and $M C (= x'')$ so that they fulfil the condition $x' + x'' = B C$.

Example.—The main span consists of a steel wire at quarter breaking strain. The span post $C F$ is 120 feet high, the checkpost $B K$ is 33 feet high, and the length of the back span $B C$ is 250 yards.

The size of iron wire to employ in back span, so as to leave a dip of 3 feet below K , is required.

Assume $c = 2300$ feet. Then calling $c = 100$, $d' = \frac{3}{23} = 0.13$, and $d'' = \frac{90}{23} = 3.913$. Whence from Table II. we find $x' = 5 + \frac{5}{55} = 5.09$ and $x'' = 27 + \frac{246}{279} = 27.81$. This gives $B C = x' + x'' = 32.90 = 252.23$ yards, which is somewhat too large.

Assume, then, $c = 2250$. We now find $d' = 0.13$ and $d'' = 4$. Whence $x' = 5.145$ and $x'' = 28.187$. This gives $BC = x' + x'' = 33.332 = 249.99$ yards = 250 almost exactly.

We may therefore take $c = 2250$. The value of the ordinate (l'') or the back span side of the insulator is $2,250 + 90 = 2,340$; and we know the value of the ordinate (l') on the main span side of the insulator = 13,200 (steel strand at quarter breaking strain). We have already shown that

$$\frac{w''}{w'} = \frac{l'}{l''}$$

where w'' is the weight per unit of length of the iron wire on the back span, and w' the weight per unit of length of the steel wire on the main span.

Hence, in this case—

$$\begin{aligned} w'' &= \frac{13200}{2340} w' \\ &= 5.641 w' \end{aligned}$$

That is to say, the back span wire would require to be upwards of five and a-half times the weight (for equal lengths) of the main span wire.

The wire in the back span would be at a strain only a little over $\frac{1}{8}$ breaking strain.

R. S. J. BROUGH.

Calcutta, July 24th, 1877.

APPENDIX.

GILBERT'S TABLE, No. I.

 $w = 100 =$ half span.*Ordinary Catenary.*

c =parameter	d = dip.	s = length of wire.	l = ordinate at insulator.	Angle at insulator.		
				α	β	γ
2000	2-500511	100-041474	2002-500511	87	8	11
1950	2-564593	100-042440	1952-564593	87	3	46
1900	2-632163	100-045727	1902-632163	86	59	8
1850	2-703298	100-047540	1852-703298	86	54	15
1800	2-778421	100-050163	1802-778421	86	49	6
1750	2-857914	100-054318	1752-857914	86	43	40
1700	2-942018	100-057566	1702-942018	86	37	53
1650	3-031204	100-060788	1653-031204	86	31	46
1600	3-125974	100-064421	1603-125974	86	25	16
1550	3-226852	100-068245	1553-226852	86	18	21
1500	3-334558	100-073939	1503-334558	86	10	59
1450	3-449618	100-078929	1453-449618	86	3	6
1400	3-572907	100-084490	1403-572907	85	54	39
1350	3-705344	100-090750	1353-705344	85	45	35
1300	3-847958	100-097440	1303-847958	85	35	45
1250	4-002035	100-105463	1254-002035	85	25	16
1200	4-168981	100-114680	1204-168981	85	13	51
1150	4-350543	100-125801	1154-350543	85	1	26
1100	4-548545	100-137346	1104-548545	84	47	54
1050	4-765440	100-150553	1054-765440	84	33	5
1000	5-004084	100-165906	1005-004084	84	16	48
980	5-106408	100-173025	985-106408	84	9	49
960	5-213007	100-180582	965-213007	84	2	13
940	5-324098	100-188974	945-324098	83	54	58
920	5-440045	100-196191	925-440045	83	47	4
900	5-561266	100-205825	905-561266	83	38	48
880	5-687876	100-214837	885-687876	83	30	11
860	5-820479	100-225255	865-820479	83	21	9
840	5-959364	100-235949	845-959364	83	11	42
820	6-105033	100-247321	826-105033	83	1	47
800	6-258102	100-260296	806-258102	82	51	23
780	6-418938	100-273356	786-418938	82	40	28
760	6-588360	100-288153	766-588360	82	28	57
740	6-767004	100-304328	746-767004	82	16	50
720	6-955577	100-321527	726-955577	82	4	3
700	7-154926	100-339869	707-154926	81	50	33
680	7-366193	100-360765	687-366193	81	36	15
660	7-590181	100-382517	667-590181	81	21	6
640	7-828368	100-407143	647-828368	81	5	1
620	8-081923	100-433570	628-081923	80	47	54

GILBERT'S TABLE NO. I.—*continued.*

c =parameter	d = dip.	s = length of wire.	l = ordinate at insulator.	Angle at insulator.		
				α	β	γ
600	8.352608	100.463404	608.352608	80	29	40
580	8.642033	100.495985	588.642033	80	10	11
560	8.952299	100.532176	568.952299	79	49	27
540	9.283888	100.562366	549.283888	79	27	2
520	9.645021	100.617335	529.645021	79	2	56
500	10.033315	100.667683	510.033315	78	36	59
480	10.454508	100.725490	490.454508	78	8	55
460	10.912412	100.789382	470.912412	77	38	28
440	11.412622	100.863052	451.412622	77	5	23
420	11.961025	100.947150	431.961025	76	29	6
400	12.565207	101.044792	412.565207	75	49	22
380	13.233994	101.158163	393.233994	75	5	35
360	13.978365	101.290757	373.978365	74	17	7
340	14.812141	101.447796	354.812141	73	32	10
320	15.752501	101.635337	335.752501	72	22	46
300	16.821529	101.862069	316.821529	71	14	44
280	18.047685	102.139232	298.047685	69	57	31
260	19.468993	102.483745	279.468993	68	29	13
240	21.126437	102.893226	261.126437	66	47	38
220	23.118850	103.473548	243.118850	64	48	38
200	25.525175	104.219022	225.525175	62	28	34
180	28.559946	105.343499	208.559946	59	39	43
160	32.280531	106.638654	192.280531	56	19	0
140	37.258541	108.722538	177.258541	52	10	2
120	44.134402	111.982596	164.134402	46	58	48
100	54.308027	117.520071	154.308027	40	23	42
95	57.674415	119.517684	152.674415	38	28	45
90	61.511583	121.884206	151.511583	36	26	34
85	65.852160	124.624934	150.852160	34	17	44
80	71.073875	128.153485	151.073875	31	58	28
75	77.147407	132.377616	152.147407	29	32	4
70	84.433443	137.657866	154.433443	26	57	10

GILBERT'S TABLE NO. II.

 $c = 100 =$ parameter.*The Ordinary Catenary.*

x =half span.	d = dip.	s = length of wire.	l = ordinate at insulator.	Angle at insulator.		
				α	β	γ
1	·004999	1·000000	100·004999	89	25	39
2	·020000	2·000100	100·020000	88	51	15
3	·045001	3·000398	100·045001	88	16	53
4	·080007	4·000992	100·080007	87	42	31
5	·125025	5·002074	100·125025	87	8	11
6	·180050	6·003540	100·180050	86	33	51
7	·245098	7·005701	100·245098	85	59	33
8	·320170	8·008520	100·320170	85	25	16
9	·405271	9·012128	100·405271	84	51	1
10	·500408	10·016591	100·500408	84	16	48
11	·605609	11·022190	100·605609	83	42	36
12	·720855	12·028744	100·720855	83	8	37
13	·846186	13·036613	100·846186	82	34	20
14	·981591	14·045708	100·981591	82	0	14
15	1·127107	15·056292	101·127107	81	26	15
16	1·282710	16·068289	101·282710	80	52	17
17	1·448471	17·081928	101·448471	80	18	22
18	1·624373	18·097326	101·624373	79	44	31
19	1·810427	19·114472	101·810427	79	10	43
20	2·006663	20·133536	102·006663	78	36	59
21	2·213114	21·154685	102·213114	78	3	19
22	2·429763	22·177836	102·429763	77	29	43
23	2·656680	23·203319	102·656680	76	56	11
24	2·893847	24·231042	102·893847	76	22	45
25	3·141302	25·261197	103·141302	75	49	22
26	3·399061	26·293838	103·399061	76	16	5
27	3·667187	27·329212	103·667187	74	42	53
28	3·145662	28·367237	103·945662	74	9	46
29	4·234542	29·408157	104·234542	73	36	44
30	4·533833	30·451966	104·533833	73	3	48
31	4·843577	31·498822	104·843577	72	30	58
32	5·163822	32·548877	105·163822	71	58	13
33	5·494589	33·602210	105·494589	71	25	35
34	5·835881	34·658818	105·835881	70	53	3
35	6·187768	35·718931	106·187768	70	20	36
36	6·550276	36·782623	106·550276	69	48	18
37	6·923431	37·849968	106·923431	69	16	6

GILBERT'S TABLE No. II.—*continued.*

x =half span.	d = dip.	s =length of wire.	l = ordinate at insulator.	Angle at insulator.		
				°	'	"
38	7.307284	38.921115	107.307284	68	44	0
39	7.701863	39.096336	107.701863	68	12	1
40	8.107217	41.075182	108.107217	67	40	10
41	8.523379	42.158320	108.523379	67	8	25
42	8.950402	43.245697	108.950402	66	36	48
43	9.388315	44.337384	109.388315	66	5	19
44	9.837146	45.433453	109.837146	65	33	57
45	10.297011	46.534188	110.297011	65	2	43
46	10.767851	47.639448	110.767851	64	31	46
47	11.249817	48.749582	111.249817	64	0	39
48	11.742877	49.864522	111.742877	63	29	49
49	12.247092	50.984407	112.247092	62	59	7
50	12.762587	52.109512	112.762587	62	28	34
51	13.289300	53.239600	113.289300	61	58	9
52	13.827388	54.375311	113.827388	61	27	53
53	14.376853	55.516346	114.376853	60	57	45
54	14.937727	56.662872	114.937727	60	27	46
55	15.510107	57.815092	115.510107	59	57	56
56	16.094061	58.973138	116.094061	59	28	14
57	16.689588	60.137011	116.689588	58	58	42
58	17.296790	61.306900	117.296790	58	29	19
59	17.915770	62.483020	117.915770	58	0	5
60	18.546493	63.665306	118.546493	57	31	1
61	19.189099	64.854000	119.189099	57	2	5
62	19.843586	66.049113	119.843586	56	33	20
63	20.510098	67.250901	120.510098	56	4	43
64	21.188633	68.459366	121.188633	55	36	16
65	21.879300	69.674600	121.879300	55	7	59
66	22.582171	70.897028	122.582171	54	39	42
67	23.297283	72.126416	123.297283	54	11	54
68	24.024709	73.362990	124.024709	53	44	6
69	24.764560	74.606930	124.764560	53	16	28
70	25.516873	75.858326	125.516873	52	48	59
71	26.281725	77.117274	126.281725	52	21	41
72	27.059265	78.384034	127.059265	51	54	33
73	27.849426	79.659573	127.849426	51	27	34
74	28.652451	80.941048	128.652451	51	0	46
75	29.468327	82.231672	129.468327	50	34	8

GILBERT'S TABLE NO. II.—*continued.*

x —half span.	d = dip.	s = length of wire.	l = ordinate at insulator.	Angle at insulator.		
				o	s	a
76	30·297123	83·530476	130·297123	50	7	40
77	31·138956	84·837643	131·138956	49	41	22
78	31·993903	86·153296	131·993903	49	15	14
79	32·862044	87·477555	132·862044	48	49	16
80	33·743457	88·810452	133·743457	48	23	29
81	34·638263	90·152436	134·638263	47	57	52
82	35·546581	91·503418	135·546581	47	32	25
83	36·468371	92·863428	136·468371	47	7	8
84	37·403837	94·232762	137·403837	46	42	2
85	38·353056	95·611543	138·353056	46	17	6
86	39·316110	96·999880	139·316110	45	52	20
87	40·293084	98·397915	140·293084	45	27	45
88	41·284143	99·805856	141·284143	45	3	20
89	42·289243	101·223656	142·289243	44	39	5
90	43·308592	102·651607	143·308592	44	15	1
91	44·342313	104·089886	144·342313	43	51	7
92	45·390455	105·538544	145·390455	43	27	23
93	46·430931	106·967368	146·430931	43	4	18
94	47·530444	108·467655	147·530444	42	40	26
95	48·622506	109·948393	148·622506	42	17	13
96	49·729447	111·440152	149·729447	41	54	10
97	50·851184	112·943315	150·851184	41	31	18
98	51·988313	114·457186	151·988313	41	8	36
99	53·140537	115·982862	153·140537	40	46	4
100	54·308027	117·520072	154·308027	40	23	42

IMPROVED MAKE AND BREAK FOR SIR WILLIAM THOMSON'S RECORDER MILL.

In the interests of science, and as a step on the road of progress, I deem it right to lay before the Society of Telegraph Engineers an important improvement in the make and break portion of the "mill" attached to Sir William Thomson's Siphon Recorder, designed and made by the mechanic at the Valentia Station, Mr. H. Windeler.

The ordinary make and break spring as supplied with the Recorder by Messrs. White and Co., of Glasgow, is a simple steel spring carrying the upper platinum contact as shown in fig. 1.

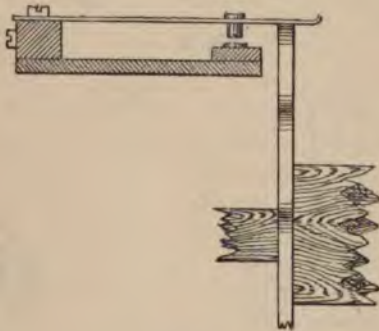

Fig. 1.

The friction of the decagonal cam, however well lubricated, wears the spring through (according to my experience) in from six to eight weeks at the point of contact; the spring is then too short for further use, and the platinum contact is also too short to use again for the same purpose.

Finding it very inconvenient to be thus frequently renewing the springs and contacts, we turned our attention to improving upon the arrangement, and this resulted in the make and break jockey now brought to notice, and which, I may mention, has been in constant use night and day for eighteen months, and shows no

more sign of wearing out than when it was first put into action. It is made of light steel and brass. Fig. 2 gives a side view of it, fig. 3 a vertical view looking downwards, and fig. 4 an end

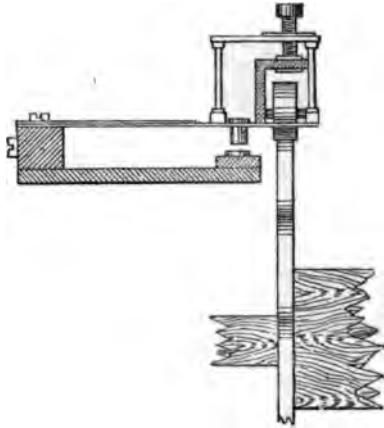

Fig. 2.

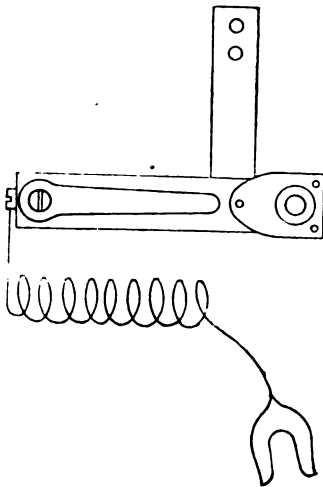

Fig. 3.

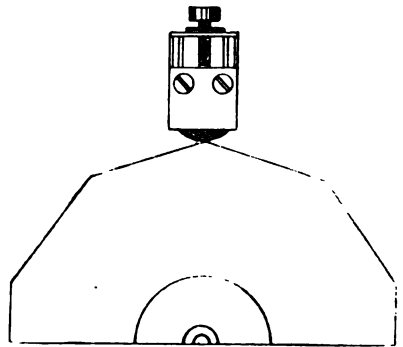

Fig. 4.

view, showing the roller on an angle of the cam breaking the contact as shown in fig. 2.

The adjusting screw at the top raises or lowers the roller at

pleasure. The range to which this motion is limited in this particular one is nearly an eighth of an inch. This can, of course, be increased in future ones if desired. Raising the roller reduces the length of contact at the angles of the cam, and lengthens the "make"; lowering the roller on the contrary lengthens the contact with the cam and increases the time of the "break." As the ordinary adjustment moves the whole frame together, this furnishes a supplementary adjustment, but the chief advantage lies in the compensating for the wear of the platinum contacts. As these reduce by wear and become gradually disintegrated (the bottom one more especially so), the roller can be raised and still allow the contacts to meet, thus effecting a great saving in platinum, as well as supplying a spring which in practice will run for years without renewal.

JAS. GRAVES.

Valentia, Ireland,
18 May, 1877.

ABSTRACTS AND EXTRACTS.

ON THE GENERAL THEORY OF DUPLEX TELEGRAPHY.

By LOUIS SCHWENDLER.

Paper read before the Asiatic Society of Bengal.

(Continued from p. 539, Vol. III.)

The first part of this investigation concluded by giving the best relations between the resistances of the different branches of the bridge arrangement, under the limiting supposition, however, that the line used for duplex working was perfect in insulation, or more generally that the real conduction resistance of the line could be neglected against the resistance of the resultant fault.*

It now remains, therefore, to investigate if the simple relations given are generally true; or, if not, what they become in case the line has an appreciable leakage. In fact this is clearly the case of practical importance, since all overland lines, especially long ones, even if constructed on the best known principles, will always have a very considerable leakage, *i.e.*, the resistance of the resultant fault (δ) will generally be by no means very large in proportion to the real conduction resistance (L) of the line.

In order to obtain the best general solution of the problem, we must conduct the investigation with great caution, that is, we must be careful not to introduce beforehand any relation between the different variables, however convenient, that is not necessarily a consequence of the paramount condition to be fulfilled for Duplex Telegraphy, *i.e.*, Regularity of Signals.

Thus it will be seen that the present general investigation must be conducted somewhat differently from the special one given in the first part.

* For a definition of the terms "resultant fault," "real conduction," "measured conduction," "real insulation," "measured insulation," &c., which will be of frequent occurrence in this paper, see my *Testing Instructions*, Part II., Section I.

It must, however, be understood from the beginning that, whatever the best relations may be which should exist between the different resistances of the bridge method when used on an imperfect line, these relations must revert to the special ones given before if we put $i = \infty$, and this fact affords a certain check upon the correctness of the new relations to be found.

General Solution of the First Problem for the Bridge Method.

The diagram (fig. 1) given in the first part represents the general case, and to it therefore I shall refer in the present paper.

The general mathematical question which is to be solved for Duplex Telegraphy has been stated as follows:—

REGULARITY OF SIGNALS.—D and S are two functions which must be rigidly equal to zero when no variation in the system occurs; and which for any given variation in the system must be as small as possible, and approximate rapidly towards zero as the variation in the system becomes smaller and smaller.

Further these two functions D and S were expressed, say for Station (I), as follows—

$$D' = \frac{E' N'' 1 \Delta'}{E'' N' \mu' m'' \psi'} \dots \dots \dots \text{(III')}$$

and
$$S' = E'' \frac{m''}{N''} \mu' \psi' - \frac{E' b'}{n'} + \sigma' \phi' \dots \dots \text{(IV')}$$

These two expressions are quite general, *i.e.* they do not as yet contain any restrictive conditions (beyond those involved by the mode of arrangement of the system of conductors) between the different variables; and the signification of the abbreviated terms can be found from the first part.*

* For convenience of reference I shall give here all the terms of which use will be made hereafter.

$$\begin{aligned} n &= b(a + d + g + f) + (a + g)(f + d). \\ m &= b(g + d) + d(a + g). \\ k &= b(a + f) + a(f + d). \\ \psi &= \frac{k}{n}. \\ \rho &= \frac{\alpha}{n} \\ \alpha &= b(g + d)(a + f) + a g(d + f) + f d(a + g). \end{aligned}$$

These expressions have been obtained by the application of Kirchoff's rules to the

Now the first relation that we shall introduce is $w + \beta = f$ for both stations, which may be called most appropriately "the key equation."

The introduction of this relation at the outset is quite justified, for say that $S' = D' = 0$ is rigidly fulfilled in station (I), when station (I) is sending and the key in station (II) is at rest, and suppose the electromotive force in station (II) equals 0 (the E. M. F. of all elements annulled and only their resistance β'' left), then, moving the key in station (II) from its rest contact to its working contact, the regularity condition $S' = D' = 0$ would be (*i.e.* balance in station I) at once disturbed if $w'' + \beta'' \neq f''$ during the motion of the key, even if no variation in the line took place. Thus it is paramount to have $w + \beta = f$ for each station during the movement of the key.*

But if for instance in station (I)

$$w' + \beta' = f'$$

it follows that

$$\phi' = \psi \cdot \dagger$$

Hence, substituting its value for σ' and reducing, we get more simply,

$$S' = \frac{E' m'}{N'} \psi' - \frac{E' b'}{n'} \dots \dots \dots (IV')$$

Bridge Arrangement as represented in fig. 1, and they are quite general, as no other relations beyond those represented by the diagram have been introduced as yet.

* To fulfil the key equation most exactly during the movement of the key, I have constructed a key (constant resistance key) based on the following principle: During the first movement of the key (up or down stroke) a force is stored up in a spring before the contacts are changed, which force finally causes the change in these contacts; for this reason the two principal contacts of the key co-exist only for an almost infinitesimal time, the length of which is moreover independent of the signalling speed. Thus for this key $w + f = \beta$ is fulfilled in all positions except one, when it is $\frac{w + \beta}{2}$, but for such a short time that the error cannot have any disturbing influence whatever.

† ψ' is the proportion of the total current arriving at point 1 fig. 1, which passes off through the instrument g' when the key of station (I) is at rest. Then ψ' , being a r function of $a', b', d' g'$, is also a function of f' . ϕ' is the proportion of the total current arriving at point 1 fig. 1, which passes through the instrument g' when the key of station (I) is sending, thus, besides being a function of a', b', d' , and g' , it is a function of $w' + \beta'$ instead of f' , and as ϕ' and ψ' are otherwise quite similar functions they become identical if we make

$$f' = w' + \beta'$$

but as

$$\frac{m'}{N'} = \frac{b'}{k' - \frac{\Delta' n'}{m'}}$$

and

$$\psi' = \frac{k'}{n'}$$

we have

$$S' = \frac{E' b'}{n'} \left\{ \frac{1}{1 - \frac{\Delta'}{m' \psi'}} - 1 \right\} \dots (IV').$$

Therefore S' approximates most rapidly* towards zero if $\frac{\Delta'}{m' \psi'}$ does, or we have

$$\theta = \frac{\Delta'}{m' \psi'}$$

should be as small as the circumstances will allow of.

Now that D' approximates also rapidly towards zero by making

$$\theta = \frac{\Delta'}{m' \psi'}$$

as small as possible can be proved as follows:—

By definition we have $D' = \frac{p'}{P'}$

Further, as $\phi' = \psi'$ (on account of the key equation), we have $p' = S'$ invariably

$$\therefore D' = \frac{S'}{P'}$$

Thus D' for any given P' approximates towards zero at the same rate as S' does, *i.e.*, the smaller θ becomes.

Therefore the whole problem is actually most generally solved by making

$$\theta = \frac{\Delta}{m \psi}$$

as small as possible for both stations.

Now for station (I), if balance in the g' branch for the outgoing current be established, we have

$$a' d' - b' c' = 0$$

* $\frac{E' b'}{n'}$ can never become zero, but should on the contrary be as large as possible, and, therefore, S' can only approximate towards zero by $\frac{\Delta'}{m' \psi'}$ becoming as small as possible.

where c' is the "measured circuit" from station (I); and, supposing that all variations in the system are chiefly due to variations in the line of resistance,* we have at once :

$$-b' \delta c' = \Delta'.$$

$\delta c'$ the total variation of the line resistance may be either positive or negative, and supposing that $\delta c'$ contains its sign we have—

$$\theta' = \frac{\delta c'}{m' \psi' / b'}$$

to be made as small as possible.

Now in case of the line being perfect ($i = \infty$) $\delta c' = \delta L$ (a constant with respect to the different resistances of each arrangement, and which was the case in the first solution). At present however $\delta c'$ is a function of the resistances of the two arrangements, which function must be first determined before we can decide what general condition makes θ' as small as possible.

We have

$$c' = l' + \frac{i(l'' + \rho'')}{i + l'' + \rho''}$$

ρ'' being the complex resistance of Station (II).

Put

$$l' = x$$

and

$$l' + l'' = L''$$

$$\therefore c' = x + \frac{i(L - x + \rho'')}{i + L - x + \rho''}.$$

Now c' may vary from three essentially different causes, namely :—

1. x varies, or the position of the resultant fault alters ;
2. i varies, or the resistance of the resultant fault alters ;
3. L varies, or the real conduction of the line alters, as may happen by an increase or decrease of the temperature along the whole length of the line, or by the occurrence of a partial discontinuity (imperfect joints, loose shackles, &c.).

* The variations in c' may be due to variations in the line, or to variations in the duplex arrangements. In the latter case they may be due either to an alteration of temperature in the station and then the effect can be only small, or to an accident (wire or connection breaking), and then the influence will become so great that nothing short of actual repairs could help. Thus practically the problem has only to be solved for variations in the line.

These three causes may act separately or conjointly, and their total effect we can approximately get by taking the total differential of c' with respect to x , i , and L .

$$\therefore dc' = \frac{dc'}{dx} dx + \frac{dc'}{di} di + \frac{dc'}{dL} dL$$

or
$$\delta c' = \frac{dc'}{dx} \delta x + \frac{dc'}{di} \delta i + \frac{dc'}{dL} \delta L \quad \text{approximately,}$$

which expression is perfectly true, however, for small variations δx , δi , and δL .

Now*
$$\frac{m' \psi'}{b'} = \frac{N'}{n'} + \delta c' = \rho' + c' + \delta c',$$

$$\therefore \theta = \frac{\frac{dc}{dx} \delta x + \frac{dc'}{di} \delta i + \frac{dc'}{dL} \delta l}{\rho' + c' + \delta c'}$$

But as δx , δi , and δL are very small, and as neither $\frac{dc'}{dx}$ nor $\frac{dc'}{di}$ can become infinite, it follows that $\delta c'$ must be always very small in proportion to c' itself, and more so as compared with $\rho' + c'$.

*
$$\frac{m'}{N'} = \frac{b'}{K' - \Delta} \cdot \frac{n'}{m'}$$

$$\therefore \frac{N'}{m'} = \frac{K'}{b'} - \frac{\Delta'}{b'} \cdot \frac{n'}{m'}$$

or
$$\frac{K'}{b'} = \frac{N'}{m'} + \frac{\Delta'}{b'} \cdot \frac{n'}{m'}$$

but
$$\Delta' = b' \delta c'$$

$$\therefore \frac{K'}{b'} = \frac{N'}{m'} + \delta c' \cdot \frac{n'}{m'}$$

Now
$$\frac{m' \psi'}{b'} = \frac{K'}{b'} \cdot \frac{m'}{n'}$$

Substituting for $\frac{K'}{b'}$ its value we get

$$\frac{m' \psi'}{b'} = \frac{N'}{n'} + \delta c'$$

but
$$N' = c' n' + a'$$

$$\therefore \frac{N'}{n'} = c' + \frac{a'}{n'}, \text{ but } \frac{a'}{n'} = \rho'$$

$$\therefore \frac{N'}{n'} = c' + \rho'$$

or
$$\frac{m' \psi'}{b'} = c' + \rho' + \delta c'.$$

Thus we have at last

$$\theta' = \frac{\frac{dc'}{dx} \delta x}{\rho' + c'} + \frac{\frac{dc'}{di} \delta i}{\rho' + c'} + \frac{\frac{dc'}{dL} \delta L}{\rho' + c'}$$

and therefore to make θ' , for independent variations δx , δi , and δL , as small as possible, each term should be made as small as possible. Now, taking ρ' and ρ'' as independent variables, it will be seen that the total differential of each term is negative. Thus θ' becomes smaller the larger ρ' and ρ'' are selected, and the same of course is the case for θ'' (Station II).

Now the complex resistance of any one station can be expressed as follows:—

$$* \rho = \frac{(a+f)(g+d)}{a+g+d+f} - \frac{(ad-gf)^2}{(a+d+g+f)\{b(a+d+g+f) + (a+g)(f+d)\}}$$

Thus for any given sum of resistances, *i.e.*, $a+f+d+g = \text{const.}$, ρ will be largest if

$$ad - gf = 0 \quad \dots \dots \dots \text{(VI)}$$

which is the "immediate balance condition."

The fulfilment of the immediate balance condition is therefore no longer an assumption made to afford convenient and quick means of adjustment when balance is disturbed, but, as has been proved, is necessary in order to reduce the effect of any disturbance whatever to a minimum.

Supposing now the fulfilment of the immediate balance, we have

$$\rho = \frac{(g+d)(a+f)}{a+d+f+g}$$

which again has a relative maximum for

$$g + d = a + f$$

whence it follows, in consequence of equation (VI), that

$$a = d = f = g \quad \dots \dots \dots \text{(VIII)}$$

represents the general solution of the problem.

This result might of course have been anticipated from the special solution, since equation (VIII) gives only a relation be-

* This expression is nothing else but the resistance of a Wheatstone's bridge between the two battery electrodes. It is most easily obtained by the application of Kirchoff's rules.

tween the branches, quite independent of i . It remains now to determine the magnitude of one of the branches, and to this end we have to consider the magnetic moments of the receiving instruments.

MAXIMA MAGNETIC MOMENTS.—By definition we have

$$S = P - Q$$

for both stations, and, as it has been proved before quite generally that $S = 0$, if $\Delta = 0$, *i.e.*, if rigid balance in the station for the outgoing current be established, we know at once that at or near balance the currents which in one and the same station produce single and duplex signals must be identical, and need therefore express the magnetic moment in each station for one current only, by presupposing balance in both the stations.

The currents which at or near balance produce the signals are

$$* G' = \frac{E''}{4} \cdot \frac{\mu'}{g'' + c''} \quad \text{in Station (I).}$$

and

$$* G'' = \frac{E'}{4} \cdot \frac{\mu''}{g' + c'} \quad \text{,, ,, (II).}$$

These expressions follow from the general formulæ by fulfilling the regularity equation (VIII) for both stations, and in addition the balance conditions.

* For balance in Station (II) the current passing through Station (I) is

$$G' = E' \frac{b'}{K'} \mu' \psi'$$

$$\frac{K'}{n'} = \psi'$$

$$\therefore G' = E' \frac{b'}{n'} \mu' \psi'$$

but $\psi' = \psi''$ on account of $a = d = g = f$ in each station

$$\therefore G' = E' \frac{b'}{n'} \mu'$$

$$\text{but } n' = 4g'(g' + b'),$$

and dividing by b' we get

$$G' = \frac{E'}{4} \cdot \frac{\mu'}{g' + \frac{g'^2}{b'}}$$

but $g'^2 = b'c'$ on account of balance in station (II)

$$\therefore G' = \frac{E'}{4} \cdot \frac{\mu'}{g' + c'}$$

Multiplying now G' by $\sqrt{g'}$ and G'' by $\sqrt{g''}$, we get

$$P' = \frac{E''}{4} \cdot \frac{\sqrt{g'}}{g'' + c''} \mu'$$

$$P'' = \frac{E'}{4} \cdot \frac{\sqrt{g''}}{g' + c'} \mu'',$$

the magnetic moments of the two instruments in Nos. (I) and (II) stations respectively; and, considering that*

$$\frac{\mu'}{g'' + c''} = \frac{\mu''}{g' + c'} = \frac{i}{Q}$$

where $Q = (g' + l') (g'' + l'') + i (g' + g'' + l' + l'')$, we may write the two above expressions as:—

$$P' = \frac{E''}{4} \cdot \frac{i}{Q} \sqrt{g'}$$

$$P'' = \frac{E'}{4} \cdot \frac{i}{Q} \sqrt{g''}.$$

The first expression has clearly an absolute maximum with respect to g' , and the second with respect to g'' , but these two maxima cannot be simultaneously fulfilled, and do not therefore represent a solution in this particular case. But if we consider that during a *duplex* signal both the instruments g' and g'' are in circuit, while during a *single* signal, though not both the instruments yet certainly their equivalent in resistances are in circuit, it will be clear why simultaneous maxima of the two single expressions are *not* possible. It represents simply the more general case to which the question belongs of making the magnetic moments of two instruments, connected up in the same single circuit, maxima. In this case it is well known we can do nothing more than make the sum of the magnetic moments a maximum, and here therefore we must do the very same.

Adding then we get

$$P = P' + P'' = \frac{i}{4} \frac{E'' \sqrt{g'} + E' \sqrt{g''}}{Q},$$

which expression has a maximum with respect to both g' and g''

* This can be easily shown by substituting for μ' , μ'' , c' , and c'' their actual values.

considered as independent variables, and such indeed according to the nature of the problem they really are.

Thus, differentiating P with respect to g' and g'' , we get

$$\frac{dP}{dg'} = Q - 2\sqrt{g'} \left\{ \sqrt{g'} + \frac{E'}{E''} \sqrt{g''} \right\} \frac{dQ}{dg'} = 0$$

and

$$\frac{dP}{dg''} = Q - 2\sqrt{g'} \left\{ \sqrt{g''} + \frac{E''}{E'} \sqrt{g'} \right\} \frac{dQ}{dg''} = 0.$$

But, as the same kind of instruments are employed in both the stations, we require evidently also the same force in both to produce the signals, no matter what the state of the line may be.

Thus we must put*

$$P' = P''$$

or

$$\frac{E''}{4} \frac{\sqrt{g'}}{Q} = \frac{E'}{4} \frac{\sqrt{g''}}{Q}$$

$$\therefore \frac{E''}{E'} = \frac{\sqrt{g''}}{\sqrt{g'}}.$$

Substituting this value for the proportion of the E. M. F., we get

$$Q - 4g' \frac{dQ}{dg'} = 0$$

and

$$Q - 4g'' \frac{dQ}{dg''} = 0,$$

but

$$\frac{dQ}{dg'} = g'' + l'' + i$$

and

$$\frac{dQ}{dg''} = g' + l' + i.$$

Substituting these values in the above equations and reducing; and, further, dividing the first equation by $l' + i$ and the second by $l'' + i$, we get at last

$$l'' + \frac{i l'}{i + l'} + g'' - 3g'' \left(1 + \frac{g''}{l'' + i} \right) = 0$$

and

$$l' + \frac{i l''}{i + l''} + g' - 3g' \left(1 + \frac{g'}{l' + i} \right) = 0.$$

Put $l'' + \frac{i l'}{i + l'} = L''$ measured conduction from Station (II),

* This supposition in the case of a perfect line is fulfilled by itself, since then the two instruments are not only of the same kind, but absolutely identical.

and $l' + \frac{i l''}{i + l''} = L'$ measured conduction from Station (I).

Thus, the two equations which determine the absolute magnitude of g' and g'' respectively, are

$$L' + g' - 3g' \left(1 + \frac{g'}{l' + i}\right) = 0$$

and

$$L'' + g'' - 3g'' \left(1 + \frac{g''}{l'' + i}\right) = 0,$$

from which g' and g'' can be expressed, namely,

$$g' = -\frac{1}{3}q' + \frac{1}{3}\sqrt{q'(3L' + q')} \dots (X')$$

and

$$g'' = -\frac{1}{3}q'' + \frac{1}{3}\sqrt{q''(3L'' + q'')} \dots (X'')$$

where

$$q' = i + l'$$

and

$$q'' = i + l''.$$

Supposing now $i = \alpha$, or the insulation perfect, we have $L' = L'' = L$, and

$$g' = g'' = g = \frac{L}{2}$$

the former *special* solution.

But, so long as i is not infinite, L' and L'' may be different from each other, and therefore also g' different from g'' , and, further,

$$g' = \frac{L'}{2}$$

and

$$g'' = \frac{L''}{2}$$

will be somewhat too large. These values will, however, represent a very close approximation in the case of any line in tolerably good electrical condition; and, as a line worked *duplicè* represents two lines, it can be always afforded to select the best sections, when the above values for g' and g'' will be sufficiently correct for all practical purposes, especially if it be remembered that when once g' and g'' have been fixed, they cannot be easily altered, and that, therefore, L' and L'' must be invariably certain averages, either for the whole year or for certain seasons. This, however, belongs more to the practical application than to the theory of duplex telegraphy.

The resistance of the b branch in each station can now be easily calculated from the balance equations and the values given for g' and g'' .

The value of the b branch must be calculated in order to be able to ascertain that *maximum* part of b which will have to be made variable in increments for the purpose of adjusting balance, and to this interesting question we shall revert further on.

The general solution of the problem might now be considered complete if it were not for the currents which produce the signals, of which we do not know as yet with certainty that we have the maxima in the solution given above. It must, however, be understood that this solution represents the *only true one* from our physical point of view, and that, if it should not be identical with that giving the maxima currents, when considered generally by themselves from the beginning, the solution would not be thereby invalidated; but only the duplex method in question would prove to be not quite so perfect as could be desired. The sequel however will show that the relation $a = d = g = f$ represents also the maxima currents that are possible under the circumstances. As this investigation is of great importance in forming a correct opinion of the value of the method, it will be fully gone into.

MAXIMA CURRENTS. When considering the question of currents for any telegraphic circuit, the two conditions which invariably should be fulfilled are :

Firstly.—Greatest possible constancy of current.

Secondly.—Maximum current.

How far these two conditions can be fulfilled simultaneously, depends clearly on the special circuit and the special arrangements adopted, but so much is certain, that, from a practical point of view, the first condition (constancy of current) will always be of far greater importance than the second, inasmuch as the required strength of currents can be obtained by employing cells, efficient in kind, sufficient in number, and properly arranged to suit requirements.

Thus in our case, when we consider the currents which produce the signals in duplex telegraphy, before going to the condition of maximum current, we must ascertain, first, the condition of *greatest possible constancy* of current.

Now, it has been proved before that *immediate balance* in each station is requisite in order to make the effect of any disturbance on

the receiving instrument as small as the circumstances will allow of. But as these disturbances were considered with respect to *one* and the *same* instrument, *i.e.*, independent of the magnetic moment, these disturbances are then simply due to the disturbances in the signalling current; from which it follows at once that the fulfilment of the *immediate balance* condition is required also in order to have the *greatest possible constancy* in the signalling current. Thus, when investigating the question of maxima currents, we are justified in presupposing the rigid fulfilment of the immediate balance for both stations, *i.e.*

$$a d - g f = 0.$$

Further, as it has been shown before that the fulfilment of the regularity condition

$$a = d = g = f$$

for both stations does make the effect of the disturbances still smaller, we have only to investigate the current at balance, and to show that the condition of maximum current becomes identical with the regularity condition, whence it would follow that the duplex method under consideration is perfect in every conceivable respect.

The question to be solved stands, therefore, as follows:—

Two signalling currents, the expressions of which are known, have to be made simultaneous maxima, while the different variables are linked together by four condition equations.

Thus
$$G' = E' \frac{b'}{k'} \mu' \psi'$$

the current which produces single and duplex signals in Station (I),

$$G'' = E'' \frac{b''}{k''} \mu'' \psi''$$

the current which produces single and duplex signals in Station (II),

- | | | | |
|-------------------------------------|-------------------------|---|----------------------|
| 1. | $a' d' - b' c' = 0$ | } | Condition equations. |
| balance in (g') Station (I). | | | |
| 2. | $a'' d'' - b'' c'' = 0$ | | |
| balance in (g'') Station (II). | | | |
| 3. | $a' d' - g' f' = 0$ | } | |
| 4. | $a'' d'' - g'' f'' = 0$ | | |
| immediate balance in both stations. | | | |

Now c' is a function of ρ'' , but on account of equation (4) ρ'' is independent of b'' , thus c' is also independent of b'' ; in the same way it follows that c'' is independent of b' ; thus b' and b'' can be explicitly expressed at once, and from the four condition equations we have

$$b' = \frac{a' d'}{c'}$$

$$b'' = \frac{a'' d''}{c''}$$

$$f' = \frac{a' d'}{g'}$$

$$f'' = \frac{a'' d''}{g''}$$

and, substituting these values in the expressions for G' and G'' , we get

$$G'^* = E'' i \cdot \frac{a' g'}{\{c'' (a'' + g'') + a'' (g'' + d'')\} \{q' (a' + g') + a' (g' + d')\}}$$

$$G''^* = E' i \cdot \frac{a'' g''}{\{c' (a' + g') + a' (g' + d')\} \{q'' (a'' + g'') + a'' (g'' + d'')\}}$$

where

$$q' = i + l'$$

$$q'' = i + l''$$

Put $\frac{g''}{g'} = k$

and substitute in the first expression

$$g'' = k g'$$

* If in these two expressions we put

$$i = \alpha$$

and remember that then

$$a' = a'' = a$$

$$d' = d'' = d$$

$$g' = g'' = g$$

and

$$c' = c'' = c = L + \rho$$

while

$$\rho = \frac{a(g+d)}{a+g}$$

we get

$$G' = G'' = G = E \frac{a g}{\{L(a+g) + 2 a (g+d)\} \cdot (a+g)}$$

the expression of the current which produces the signals (single and duplex) through a perfect line, as was given in the first part of this investigation (page 374).

in the second

$$g' = \frac{g''}{k}$$

when we get

$$G' = E'' i k \cdot \frac{a' g'}{\{c'' (a'' + g' k) + a'' (d'' + g' k)\} \{q' (a' + g' + a' (g' + d'))\}}$$

$$G'' = E' i \cdot \frac{a'' g''}{\{c' (g'' + a' k) + a' (g'' + d' k)\} \{q'' (a'' + g'') + a'' (d'' + g'')\}}$$

Now it will be seen that G' has clearly a maximum with respect to g' , while G'' has a maximum with respect to g'' ; thus, if we take g' as the only variable in G' (k constant) and differentiate with respect to g' , we get

$$\frac{d G'}{d g'} = 0,$$

and if we take g'' as the only variable in G'' and differentiate, we get

$$\frac{d G''}{d g''} = 0.$$

These two equations must be fulfilled simultaneously in order to have the simultaneous maxima of the two currents in question.

Executing the differentiation, and re-substituting for k its value $\frac{g''}{g'}$, we get after reduction

$$\begin{aligned} & a' a'' (c'' + d'') (q' + d') - g' g'' (a' + q') (a'' + c'') \\ & - g' (a'' + g'') \{q' (a' + g') + a' (g' + d')\} \frac{d c''}{d g'} = 0 \end{aligned}$$

and

$$\begin{aligned} & a' a'' (c' + d') (q'' + d'') - g' g'' (a'' + q'') (a' + c') \\ & - g'' (a' + g') \{q'' (a'' + g'') + a'' (g'' + d'')\} \frac{d c'}{d g''} = 0 \end{aligned}$$

while

$$\frac{d c''}{d g'} = \frac{i^2}{(q' + \rho')^2} \cdot \frac{a' (a' - d')}{(a' + g')^2}$$

$$\frac{d c'}{d g''} = \frac{i^2}{(q'' + \rho'')^2} \cdot \frac{a'' (a'' - d'')}{(a'' + g'')^2}$$

Now the terms in the two equations which have $\frac{d c''}{d g'}$ and $\frac{d c'}{d g''}$ for factors become independently zero, the first for $a' = d'$, and

the second for $a''=d''$; and, substituting these values for d' and d'' in the other two terms, both become zero for

$$a' a'' - g' g'' = 0$$

whence it follows that $a' - d' = 0$

$$a'' - d'' = 0$$

$$a' a'' - g' g'' = 0$$

is one of the simultaneous solutions of the two equations.*

Thus, substituting for d' its value a' , and for d'' its value a'' , we get

$$G' = E'' i \frac{a' g''}{(c'' + a'') (a'' + g'') (a' + g') (a' + q')}$$

$$G'' = E' i \frac{a'' g'}{(c' + a') (a' + g') (a'' + g'') (a'' + q'')}$$

The first equation has clearly a maximum with respect to a' , and the second with respect to a'' , namely,

$$\frac{d G'}{d a'} = 0, \text{ which gives } a' = g',$$

and $\frac{d G''}{d a''} = 0, \text{ which gives } a'' = g''.$

Thus it follows generally that $a = d = g$ represents a maximum of the currents, and this, in consequence of the immediate balance, gives at least

$$a = d = g = f$$

the known regularity condition, which thus has also to hold good in order to make the two currents G' and G'' simultaneous maxima.

The first problem for the bridge method has therefore now been generally solved, and the results are expressed by the following formulæ :

$$a = d = f = g = w + \beta$$

$$g = H \left(\sqrt{1 + \frac{L}{H}} - 1 \right)$$

where $H = \frac{q}{3} = \frac{l + i}{3}$

* The other solutions which are possible from a mathematical point of view are however impossible with respect to the physical problem, for the quantities being all electrical resistances must be taken with the same sign, say positive.

When the insulation is perfect ($i = \infty$) the results revert to those originally obtained in the special solution, viz.—

$$a = d = f = g = w + \beta$$

$$g = \frac{L}{2}$$

$$b = \frac{L}{6}$$

It will be clear that the given solution fulfils the following conditions, which are necessary and sufficient to place duplex telegraphy on a par with single telegraphy.

I. Any variation in the resistance of the line has the least possible disturbing effect on the receiving instrument.

II. Any disturbance can be eliminated by a single adjustment in the b branch without disturbing balance in the distant station.

III. Maximum magnetic moment of the receiving instrument.

IV. Maximum current.

There seems to me to be no other method that can fulfil all these conditions simultaneously, and the “double balance”* method must therefore be pronounced perfect in every conceivable respect. I am convinced that, if the general problem of duplex working were investigated by means of the variation calculus, the double balance method would come out as the final and only solution.†

* I have called this method the “double balance” method, since there are two balances to be fulfilled in each station, namely, balance in the b branch for the arriving current and balance in the g branch for the outgoing current.

† The double balance method was introduced on one of the important Bombay Calcutta main lines in June last. Since then this duplex method has been working so satisfactorily and with such regularity and speed, even during the worst time of the year (south-west monsoon)—when necessarily the insulation as well as the inductive capacity of lines are so enormously variable, that about its thorough practicability no doubt can be entertained, and Col. Robinson, Director-General of Telegraphs in India, has consequently decided to introduce this duplex method also on the other long main lines of India.

At present the apparatus for the Bombay-Madras line (worked direct 800 miles) is almost finished, and the apparatus for Calcutta-Rangoon is under manufacture.

The Calcutta-Bombay main line is worked *duplicé* with Jabalpur only in translation; distance between Calcutta and Jabalpur 850 miles: distance between Jabalpur and Bombay 640 miles. The wire is almost throughout No. 5½ B. W. G. (diam. = 5¼ m. m.)

This experiment, on such a large scale and made under the most unfavourable

ADDENDUM.

HISTORICAL.

When reading this paper before the Asiatic Society on the 4th February, 1874, and further, when editing the first part for publication in the Journal of the Society, I was unacquainted with the fact that a most complete history of duplex telegraphy had been published by Dr. Karl Eduard Zetzsche* (Leipzig 1865). According to Professor Zetzsche,† the bridge method of Duplex Telegraphy was already invented in 1863 by Maron, a Prussian telegraph inspector; and Dr. Zetzsche very truly remarks that the bridge method would seem to be that least affected by variations in the resistance of the line. To this, from an historical point of view, most valuable book, I refer the reader. It is to be hoped that an English translation of it may soon be published.

meteorological conditions, has proved to evidence the practicability of the "double balance" method, which certainly will invariably succeed on any line where single Telegraphy is possible.

* Die Copiertelegraphen, die Typendrucktelegraphen, und die Doppel Telegraphie, ein Beitrag zur Geschichte der electrischen Telegraphie, von Dr. Karl Eduard Zetzsche, Leipzig 1865.

† Page 125 in the work quoted.

ON A CASE OF LIGHTNING; WITH AN EVALUATION
OF THE POTENTIAL AND QUANTITY OF THE
DISCHARGE IN ABSOLUTE MEASURE.

By R. S. BROUGH.

(From the Proceedings of the Asiatic Society of Bengal for
February, 1877.)

The south-west monsoon of 1871 may be considered to have been characterised in the neighbourhood of Calcutta no less by its copious and protracted rainfall than by the violence and frequency of its thunderstorms. During the progress of one of these storms in the early part of the monsoon, one of the trees standing near the gate of the compound of the building, then occupied by the Sadr Diwáni Adálat, and now used as the European Military Hospital, in Lower Circular Road, was struck by lightning. The branches of this tree overhung the wires of the Telegraph line, from which they were only about a foot distant. The discharge passed from the tree to the wires (of which there are four), broke fourteen double-cup porcelain insulators, and passed to earth through the iron standards on which the wires are supported.

The one ends of all the four wires were connected to earth through instruments in the Calcutta Telegraph Office, at a distance of about $5\frac{1}{2}$ miles from the locality of the accident. The other ends were connected as follows to earth through instruments: the first at the Telegraph Workshops, a distance of less than a quarter of a mile; the second at the Lieutenant-Governor's residence, less than half a mile; the third at Atchipur, less than 14 miles; and the fourth at Diamond Harbour, less than 25 miles. At the moment of the discharge nothing extraordinary was noticed at any of these offices.

It is often far too generally stated in text-books that lightning invariably follows the best conductor to earth. This statement is *misleading* at the best; and is absolutely untrue if the word

“conductor” be employed in the sense to which it is usually restricted in electrical science. In this instance, for example, we find that the lightning broke 14 insulators, each having probably an electrical resistance of several thousand megohms, in preference to traversing a wire resistance of not more than 500 ohms to earth through the receiving instrument in the Telegraph workshops. The writers appear to overlook the fact (experimentally illustrated long ago by Faraday) that there is exerted a mechanical stress proportional to the square of the potential tending to produce disruptive discharge, as well as an electromotive force proportional to the simple potential tending to produce a conductive discharge. Thus the discharge may occur either along a path of minimum mechanical resistance or along a path of minimum electrical resistance. Which form of discharge will occur in any particular instance depends of course on the special circumstances of the case; but, generally speaking, as the potential increases the tendency naturally is (*cæt. par.*) for the disruptive to predominate over the conductive. In the case of lightning the potential is so great, that, for any form of “lightning-protector” to be efficient, the conductive facilities offered must be correspondingly great, that is, the protector must offer no sensible resistance to earth, otherwise a disruptive discharge may take place from the protector itself, which under these circumstances becomes merely a source of danger.* This tendency to disruptive discharge is taken advantage of to protect telegraph instruments from lightning. An earth

* It is very necessary therefore that all systems of lightning-protectors should be tested for resistance from time to time. Mr. Schwendler’s method of quantitatively testing “earths” has already been described before the Society. (*Journal A. S. of Bengal, Part II., vol. xl., 1871*). In this method two temporary auxiliary earths are required. Calling the resistance of the lightning discharger earth x , and that of the auxiliary earths respectively y and z , the three resistances $x + y = a$, $x + z = b$ and $y + z = c$ are measured by any accurate method most convenient (*e. g.* Wheatstone’s Bridge, Differential Galvanometer, Tangent or Sine Galvanometer, &c., or even an empirically calibrated galvanoscope) the mean of positive and negative readings being taken to eliminate any natural E. M. F. between the earths. From the results thus obtained the unknown resistance x can be calculated by the formula

$$x = \frac{a + b - c}{2}$$

wire is brought very near to the line wire, from which it is insulated by only a very thin stratum of air: when the potential of the line wire rises abnormally, a disruptive discharge takes place at this point and the receiving instrument is thus saved.

I have twice lately seen it stated that Sir W. Thomson found that the resistance of air to disruptive discharge decreased as the thickness of the stratum increased; and a French writer has referred the possibility of the occurrence of lightning discharges several kilometres in length to this cause. Sir W. Thomson's earlier experiments certainly showed this unexpected result, probably due to the minute distances at which he was operating, but a later series of experiments, made at larger distances, showed this result in a much less marked degree; and Sir W. Thomson himself says: "It seems most probable that at still greater distances the electromotive force will be found to be sensibly constant, as it was certainly expected to be at all distances."*

Another assertion of the text-books is that the metallic rods now employed as lightning-protectors on buildings do not "attract" lightning. This statement is literally true, according to the meaning of the word "attract," but it is untrue in effect. For such a rod lightning protector determines a line of maximum induction, and a discharge is more likely to occur at the place than if the protector were not there. Professor Clerk Maxwell does not appear to hold this opinion; but it seems to me unquestionable that if a charged thunder-cloud, driving before the wind, is carried over a building furnished with a lofty metallic rod, discharge is more likely to occur than if the rod were away. In proof of this, I may refer to the case reported by Mr. Pidgeon in "Nature," and subsequently discussed before the Society of Telegraph Engineers (Proc. 12th May, 1875), in which the flag-staff acted the part of an ordinary "lightning protector."

Professor Clerk Maxwell observed in his paper, recently read before the British Association at Glasgow, that such lightning protectors are designed rather to relieve the charged cloud than to protect the threatened building. In fact lightning-rods are legiti-

* Papers on Electrostatics and Magnetism, p. 259.

mately employed for this very purpose in the vineyards, where the object in view is to relieve charged clouds and prevent disruptive discharges and the consequent showers of hail.

Under ordinary circumstances, however, the noise and light of the lightning flash must be regarded as a very harmless, if disagreeable, way of getting rid of some of the potential energy of electrical separation.

The protection of cities on the same principle, even if necessary or desirable, would be too expensive and unsightly ever to be put in practice. But Faraday has proved, that, if our houses were made of metal, they would constantly remain at the potential of the earth, we should virtually be "under-ground," and live within them in perfect security. The iron churches occasionally employed in Europe fulfil this condition exactly. It is not of course usually practicable to live in metal houses, but we can live in almost equally effective metal cages formed by running conductors connected to earth along the summit, eaves, and corners of our houses.*

The usual rod-protectors appear to be only suitable to such structures as themselves determine lines of maximum induction, *e.g.* church spires, factory chimneys, flagstuffs, &c.

The case of lightning referred to at the beginning of this paper is of peculiar interest because we know precisely the mechanical effect produced by the flash, and from this we can work back and estimate roughly the potential and quantity of the electrical discharge.

In the first place we can calculate the force required to burst the cylindrical portion of the porcelain insulator into which the iron stalk is cemented.

Let r = radius of the inside of the cylinder

R = ,, ,, outside ,,

and F = the resistance to bursting.

Then,
$$F = f \frac{R^2 - r^2}{R^2 + r^2}$$

where $f = 66 \times 10^4$ grammes on the square centimetre.

* This portion of this paper was written before the meeting of the British Association at Glasgow.

Now the line wire was bound to the insulator by a thinner wire passing round it. The surface density could not have been uniform round the binding wire, but must have been greatest on the side touching the insulator.

By the method of electrical images in two dimensions it may be shown that the surface density (σ) on the inner side of the binding wire is approximately

$$\sigma = \frac{Q}{4 \pi^2 R \sqrt{d-a} (\sqrt{d+a} - \sqrt{d-a})}$$

where Q is the total charge on the binding wire, d the distance of the binding wire from the stalk of the insulator, and a the radius of the binding wire.

$$\text{But } 2 \pi \sigma^2 = F$$

$$\therefore \sigma = \sqrt{\frac{F}{2 \pi}}$$

Whence

$$Q = \sqrt{\frac{F}{2 \pi}} \cdot 4 \pi^2 R \sqrt{d-a} (\sqrt{d+a} - \sqrt{d-a})$$

which is the expression for the quantity of the charge on one insulator. As there were 14 insulators broken, this result must be multiplied by 14 in order to obtain the total quantity of the discharge.

Again the electrostatic capacity of the binding wire is

$$S = \frac{2 \pi R c}{\log. \epsilon \frac{d + \sqrt{d^2 - a^2}}{d - \sqrt{d^2 - a^2}}}$$

where $c = 1.9$ about.

$$\text{But } VS = Q$$

$$\begin{aligned} \therefore V = \frac{Q}{S} &= \sqrt{\frac{F}{2 \pi}} \cdot \frac{2 \pi}{c} \sqrt{d-a} (\sqrt{d+a} - \sqrt{d-a}) \\ &\times \log. \epsilon \frac{d + \sqrt{d^2 - a^2}}{d - \sqrt{d^2 - a^2}} \end{aligned}$$

which is the expression for the potential of the discharge.

Now in the particular case under consideration

$$r = 1\cdot500 \text{ c. m.}$$

$$R = 3\cdot000 \text{ c. m.}$$

$$d = 2\cdot250 \text{ c. m.}$$

$$\text{and } a = 0\cdot125 \text{ c. m.}$$

Hence $F = 396 \times 10^3$ grammes per sq. centimetre.

$$\left. \begin{array}{l} 14 Q = 50586\cdot5 \\ V = 722\cdot7 \end{array} \right\} \text{ absolute electrostatic C. G. S. units.}$$

Changing the units to the ordinary ones in practical use, we find

$$14 Q = 16\cdot86 \text{ microfarads.}$$

$$V = 216810 \text{ volts.}$$

Assuming the sparking distance to increase as the square of the potential, it can be calculated from the experimental results obtained by Messrs. Warren de la Rue and Muller (Proc. Roy. Soc. Jan. 1876), namely, that 1000-rod chloride of silver cells give a spark 0·009166 inch, that a difference of potentials of 216810 volts would produce a spark in air between two electrodes at a distance of about 36 feet apart. This is of course a relatively very short distance, but it must be remembered that we have only taken into consideration that portion of the energy of the discharge which was employed in breaking the 14 insulators, and have neglected all that was spent in heat, light, &c.

1
2
3
4
5

6
7
8

9
10
11
12
13
14
15

16

17

18

JOURNAL

OF THE

SOCIETY OF TELEGRAPH ENGINEERS.

VOL. VI.

1877.

No. 20.

Special General Meeting, held at 25, Great George Street, Westminster, on Wednesday, the 31st October, 1877. PROFESSOR ABEL, C.B., F.R.S., President, in the Chair.

The PRESIDENT: Gentlemen, the Council of the Society of Telegraph Engineers felt that they were sure of doing what the members would consider right in summoning a special meeting for the two-fold purpose of giving a welcome to Professor Bell to this country and affording the Members an opportunity of hearing from him an account, which he has been so good as to promise to give us, of the nature, history, and development of, what may well be called, one of the most interesting discoveries of our age. Our time is very precious this evening. We all desire to hear everything Professor Bell can tell us on this subject, and many gentlemen will probably desire afterwards to ask questions or discuss the subject, for I see present a great number of eminent scientific men. I will not waste another moment, but at once call upon Professor Bell to commence his discourse on the Electric Telephone.

RESEARCHES IN ELECTRIC TELEPHONY.

By PROFESSOR ALEXANDER GRAHAM BELL.

PROFESSOR BELL: Mr. President and Gentlemen of the Society of Telegraph Engineers. It is to-night my pleasure, as well as duty, to give you some account of the telephonic researches in which I

have been so long engaged. Many years ago my attention was directed to the mechanism of speech by my father, Alexander Melville Bell, of Edinburgh, who has made a life-long study of the subject. Many of those present may recollect the invention by my father of a means of representing, in a wonderfully accurate manner, the positions of the vocal organs in forming sounds. Together we carried on quite a number of experiments, seeking to discover the correct mechanism of English and foreign elements of speech, and I remember especially an investigation in which we were engaged concerning the musical relations of vowel sounds. When vowel sounds are whispered, each vowel seems to possess a particular pitch of its own, and by whispering certain vowels in succession a musical scale can be distinctly perceived. Our aim was to determine the natural pitch of each vowel; but unexpected difficulties made their appearance, for many of the vowels seemed to possess a double pitch—one due, probably, to the resonance of the air in the mouth, and the other to the resonance of the air contained in the cavity behind the tongue, comprehending the pharynx and larynx.

I hit upon an expedient for determining the pitch which at that time I thought to be original with myself. It consisted in vibrating a tuning-fork in front of the mouth while the positions of the vocal organs for the various vowel sounds were silently taken. It was found that each vowel position caused the reinforcement of some particular fork or forks.

I wrote an account of these researches to Mr. Alex. J. Ellis, of London, whom I have very great pleasure in seeing here to-night. In reply he informed me that the experiments related had already been performed by Helmholtz, and in a much more perfect manner than I had done. Indeed, he said that Helmholtz had not only analysed the vowel sounds into their constituent musical elements, but had actually performed the synthesis of them.

He had succeeded in producing, artificially, certain of the vowel sounds by causing tuning-forks of different pitch to vibrate simultaneously by means of an electric current. Mr. Ellis was kind enough to grant me an interview for the purpose of explaining *the apparatus* employed by Helmholtz in producing these extra-

ordinary effects, and I spent the greater part of a delightful day with him in investigating the subject. At that time, however, I was too slightly acquainted with the laws of electricity fully to understand the explanations given; but the interview had the effect of arousing my interest in the subjects of sound and electricity, and I did not rest until I had obtained possession of a copy of Helmholtz' great work,* and had attempted, in a crude and imperfect manner it is true, to reproduce his results. While reflecting upon the possibilities of the production of sound by electrical means, it struck me that the principle of vibrating a tuning-fork by the intermittent attraction of an electro-magnet might be applied to the electrical production of music.

I imagined to myself a series of tuning-forks of different pitches, arranged to vibrate automatically in the manner shown by Helmholtz, each fork interrupting at every vibration a voltaic current; and the thought occurred, "Why should not the depression of a key like that of a piano direct the interrupted current from any one of these forks, through a telegraph wire, to a series of electro-magnets operating the strings of a piano or other musical instrument, in which case a person might play the tuning-fork piano in one place and the music be audible from the electro-magnetic piano in a distant city?"

The more I reflected upon this arrangement the more feasible did it seem to me; indeed, I saw no reason why the depression of a number of keys at the tuning-fork end of the circuit should not be followed by the audible production of a full chord from the piano in the distant city, each tuning-fork affecting at the receiving end that string of the piano with which it was in unison. At this time the interest which I felt in electricity led me to study the various systems of telegraphy in use in this country and in America. I was much struck with the simplicity of the Morse alphabet, and with the fact that it could be read by sound. Instead of having the dots and dashes recorded upon paper, the operators were in the habit of observing the duration of the click of the instruments,

* Helmholtz. *Die Lehre von dem Tonempfindungen*. (English Translation by Alexander J. Ellis, *Theory of Tone*.)

and in this way were enabled to distinguish by ear the various signals.

It struck me that in a similar manner the duration of a musical note might be made to represent the dot or dash of the telegraph code, so that a person might operate one of the keys of the tuning-fork piano referred to above, and the duration of the sound proceeding from the corresponding string of the distant piano be observed by an operator stationed there. It seemed to me that in this way a number of distinct telegraph messages might be sent simultaneously from the tuning-fork piano to the other end of the circuit, by operators each manipulating a different key of the instrument. These messages would be read by operators stationed at the distant piano, each receiving operator listening for signals of a certain definite pitch, and ignoring all others. In this way could be accomplished the simultaneous transmission of a number of telegraphic messages along a single wire, the number being limited only by the delicacy of the listener's ear. The idea of increasing the carrying power of a telegraph wire in this way took complete possession of my mind, and it was this practical end that I had in view when I commenced my researches in Electric Telephony.

In the progress of science it is universally found that complexity leads to simplicity, and in narrating the history of scientific research it is often advisable to begin at the end.

In glancing back over my own researches I find it necessary to designate, by distinct names, a variety of electrical currents by means of which sounds can be produced, and I shall direct your attention to several distinct species of what may be termed "telephonic" currents of electricity. In order that the peculiarities of these currents may be clearly understood, I shall ask Mr. Frost to project upon the screen a graphical illustration of the different varieties.

The graphical method of representing electrical currents here shown is the best means I have been able to devise of studying in an accurate manner the effects produced by various forms of telephonic apparatus, and it has led me to the conception of that *peculiar species* of telephonic current here designated as *undu-*

latory, which has rendered feasible the artificial production of articulate speech by electrical means.



Fig. 1.

A horizontal line ($g g'$) is taken as the zero of current, and impulses of positive electricity are represented above the zero line, and negative impulses below it, or *vice versa*.

The vertical thickness of any electrical impulse (b or d), measured from the zero line, indicates the intensity of the electrical current at the point observed, and the horizontal extension of the electric line (b or d) indicates the duration of the impulse.

Nine varieties of telephonic currents may be distinguished, but it will only be necessary to show you six of these. The three primary varieties designated as “intermittent,” “pulsatory,” and “undulatory,” are represented in lines 1, 2, and 3.

Sub-varieties of these can be distinguished as “direct” or “reversed” currents according as the electrical impulses are all of one kind or are alternately positive and negative. “Direct” currents may still further be distinguished as “positive” or “negative,” according as the impulses are of one kind or of the other.

An *intermittent current* is characterised by the alternate presence and absence of electricity upon the circuit;

A *pulsatory current* results from sudden or instantaneous changes in the intensity of a continuous current; and

An *undulatory current* is a current of electricity, the intensity of which varies in a manner proportional to the velocity of the motion of a particle of air during the production of a sound: thus the curve representing graphically the undulatory current for a simple musical tone is the curve expressive of a simple pendulous vibration—that is, a sinusoidal curve.

Telephonic currents of electricity may be	Intermittent	{ Direct	Positive 1	Positive intermittent current.
			Negative 2	Negative " "
			Reversed 3	Reversed " "
	Pulsatory	{ Direct	Positive 4	Positive pulsatory current.
			Negative 5	Negative " "
			Reversed 6	Reversed " "
	Undulatory	{ Direct	Positive 7	Positive undulatory current.
			Negative 8	Negative " "
			Reversed 9	Reversed " "

And here I may remark, that, although the conception of the undulatory current of electricity is entirely original with myself, methods of producing sound by means of intermittent and pulsatory currents have long been known. For instance, it was long since discovered that an electro-magnet gives forth a decided sound when it is suddenly magnetized or demagnetized. When the circuit upon which it is placed is rapidly made and broken, a succession of explosive noises proceeds from the magnet. These sounds produce upon the ear the effect of a musical note when the current is interrupted a sufficient number of times per second. The discovery of "Galvanic Music," by Page,* in 1837, led inquirers in different parts of the world almost simultaneously to enter into the field of telephonic research; and the acoustical effects produced by magnetization were carefully studied by Marrian,† Beatson,‡ Gassiot,§ De la Rive,|| Matteucci,¶

* *C. G. Page*. "The Production of Galvanic Music." *Silliman's Journ.* 1837, xxxii. p. 396; *Silliman's Journ.* July, 1837, p. 354; *Silliman's Journ.* 1838, xxxiii. p. 118; *Bibl. Univ.* (new series), 1839, ii. p. 398.

† *J. P. Marrian*. *Phil. Mag.* xxv. p. 382; *Inst.* 1845, p. 20; *Arch. de l'Électr.* v. p. 195.

‡ *W. Beatson*. *Arch. de l'Électr.* v. p. 197; *Arch. de Sc. Phys. et Nat.* (2d series), ii. p. 113.

§ *Gassiot*. See "Treatise on Electricity," by De la Rive, i. p. 300.

|| *De la Rive*. *Treatise on Electricity*, i. p. 300; *Phil. Mag.* xxxv. p. 422; *Arch. de l'Électr.* v. p. 200; *Inst.* 1846, p. 83; *Comptes Rendus*, xx. p. 1287; *Comp. Rend.* xxii. p. 432; *Pogg. Ann.* lxxvi. p. 637; *Ann. de Chim. et de Phys.* xxvi. p. 158.

¶ *Matteucci*. *Inst.* 1845, p. 315; *Arch. de l'Électr.* v. 389.

Guillemin,* Wertheim,† Wartmann,‡ Janniar,§ Joule,|| Laborde,¶ Legat,** Reis,†† Poggendorff,‡‡ Du Moncel,§§ Delezenne,||| and others.¶¶ It should also be mentioned that Gore*** obtained loud musical notes from mercury, accompanied by singularly beautiful crispations of the surface during the course of experiments in electrolysis; Page††† produced musical tones from Trevelyan's bars by the action of the galvanic current; and further it was discovered by Sullivan‡‡‡ that a current of electricity is generated by the vibration of a wire composed partly of one metal and partly of another. The current was produced so long as the wire emitted a musical note, but stopped immediately upon the cessation of the sound.

For several years my attention was almost exclusively directed

* *Guillemin*. Comp. Rend. xxii. p. 264; Inst. 1846, p. 30; Arch. d. Sc. Phys. (2d series), i. p. 191.

† *G. Wertheim*. Comp. Rend. xxii. pp. 336, 544; Inst. 1846, pp. 65, 100; Pogg. Ann. lxxviii. p. 140; Comp. Rend. xxvi. p. 505; Inst. 1848, p. 142; Ann. de Chim. et de Phys., xxiii. p. 302; Arch. d. Sc. Phys. et Nat. viii. p. 206; Pogg. Ann. lxxvii. p. 43; Berl. Ber. iv. p. 121.

‡ *Elie Wartmann*. Comp. Rend. xxii. p. 544; Phil. Mag. (3d series), xxviii. p. 544; Arch. d. Sc. Phys. et Nat. (2d series), i. p. 419; Inst. 1846, p. 290; Monatscher. d. Berl. Akad. 1846, p. 111.

§ *Janniar*. Comp. Rend. xxiii. p. 319; Inst. 1846, p. 269; Arch. d. Sc. Phys. et Nat. (2d. series), ii. p. 394.

|| *J. P. Joule*. Phil. Mag. xxv. pp. 76, 225; Berl. Ber. iii. p. 489.

¶ *Laborde*. Comp. Rend. l. p. 692; Cosmos, xvii. p. 514.

** *Legat*. Brix. Z. S. ix. p. 125.

†† *Reis*. "Téléphonie." Polytechnic Journ. clxviii. p. 185; Böttger's Notizbl. 1863, No. 6.

‡‡ *J. C. Poggendorff*. Pogg. Ann. xcvi. p. 192; Berliner Monatsber. 1856, p. 133; Cosmos, ix. p. 49; Berl. Ber. xii. p. 241; Pogg. Ann. lxxxvii. p. 139.

§§ *Du Moncel*. Exposé, ii. p. 125; also, iii. p. 83.

||| *Delezenne*. "Sound produced by Magnetization," Bibl. Univ. (new series), 1841, xvi. p. 406.

¶¶ See London Journ. xxxii. p. 402; Polytechnic Journ. cx. p. 16; Cosmos, iv. p. 43; Glöserer—Traité général, &c. p. 350; Dove-Repert. vi. p. 58; Pogg. Ann. xliiii. p. 411; Berl. Ber. i. p. 144; Arch. d. Sc. Phys. et Nat. xvi. p. 406; Kuhn's Encyclopædia der Physik, pp. 1014-1021.

*** *Gore*. Proceedings of Royal Society, xii. p. 217.

††† *C. G. Page*. "Vibration of Trevelyan's bars by the galvanic current." Silliman's Journal, 1850, ix. pp. 105-108.

‡‡‡ *Sullivan*. "Currents of Electricity produced by the vibration of Metals." Phil. Mag. 1845, p. 261; Arch. de l'Électr. x. p. 480.

to the production of an instrument for making and breaking a voltaic circuit with extreme rapidity, to take the place of the transmitting tuning-fork used in Helmholtz' researches. I will not trouble you with the description of all the various forms of apparatus that were devised, but will merely direct your attention

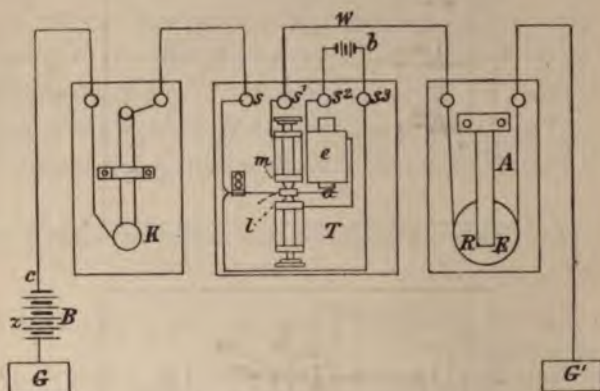

Fig. 2.

to one of the best of them, shown in fig. 2. In the transmitting instrument T, a steel reed *a* is employed, which is kept in continuous vibration by the action of an electro-magnet *e* and local battery. In the course of its vibration the reed strikes alternately against two fixed points *m*, *l*, and thus completes alternately a local and a main circuit. When the key K is depressed an intermittent current from the main battery B is directed to the line-wire W, and passes through the electro-magnet E of a receiving instrument R at the distant end of the circuit, and thence to the ground G. The steel reed A is placed in front of the receiving magnet, and when its normal rate of vibration is the same as the reed of the transmitting instrument it is thrown into powerful vibration, emitting a musical tone of a similar pitch to that produced by the reed of the transmitting instrument, but if it is normally of a different pitch it remains silent.

A glance at figs. 3, 4, and 5 will show the arrangement of such instruments upon a telegraphic circuit, designed to enable a number of telegraphic despatches to be transmitted simultaneously

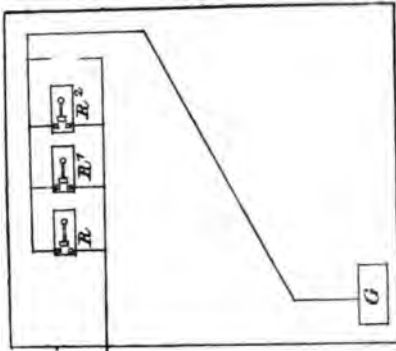

Fig. 5.

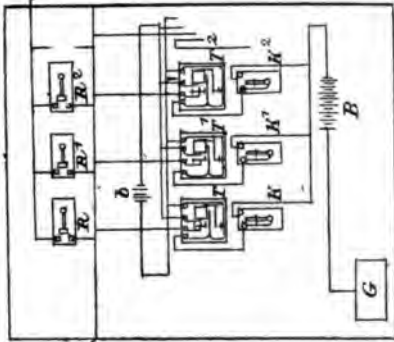

Fig. 4.

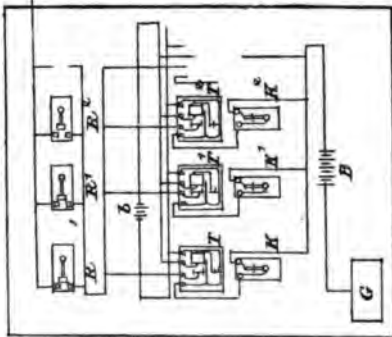

Fig. 3.

along the same wire. The transmitters and receivers that are numbered alike have the same pitch or rate of vibration. Thus the reed of T' is in unison with the reeds T' and R' at all the stations upon the circuit, so that a telegraphic despatch sent by the manipulation of the key K' at the station shown in fig. 3 will be received upon the receiving instruments K' at all the other stations upon the circuit. Without going into details, I shall merely say that the great defects of this plan of multiple telegraphy were found to consist, firstly, in the fact that the receiving operators were required to possess a good musical ear in order to discriminate the signals; and secondly, that the signals could only pass in one direction along the line (so that two wires would be necessary in order to complete communication in both directions). The first objection was got over by employing the device which I term a "vibratory circuit-breaker," shown in the next diagram, whereby musical signals can be automatically recorded.

Fig. 6 shows a receiving instrument R , with a vibratory circuit-breaker v attached. The light spring-lever v overlaps the free end of the steel reed A , and normally closes a local circuit, in which may be placed a Morse-sounder or other telegraphic apparatus. When the reed A is thrown into vibration by the passage of a musical signal, the spring arm v is thrown upwards, opening the local circuit at the point 5. When the spring-arm v is so

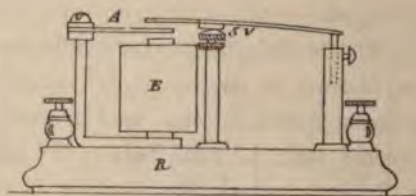

Fig. 6.

arranged as to have normally a much slower rate of vibration than the reed A_1 , the local circuit is found to remain permanently open during the vibration of A , the spring-arm v coming into contact with the point 5 only upon the cessation of the receiver's vibration. Thus the signals produced by the vibration of the reed A

are reproduced upon an ordinary telegraphic instrument in the local circuit.

Fig. 7 shows the application of electric telephony to auto-graphic telegraphy.

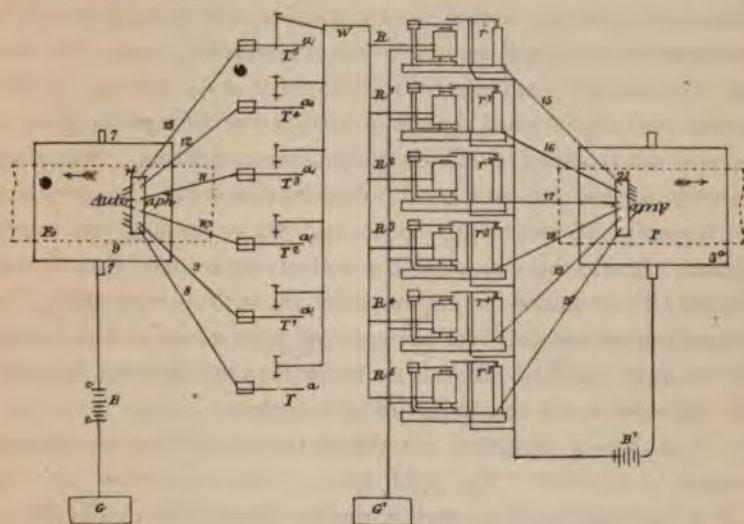

Fig. 7.

T, T', &c., represent the reeds of transmitting instruments of different pitch, R, R', &c., the receivers at the distant station of corresponding pitch, and, r, r', &c., the vibratory circuit-breakers attached to the receiving instruments, and connected with metallic bristles, 21, resting upon chemically prepared paper P. The message, or picture, to be copied, is written upon a metallic surface, Fo, with non-metallic ink, and placed upon a metallic cylinder 7, connected with the main battery B; and the chemically prepared paper P, upon which the message is to be received, is placed upon a metallic cylinder connected with the local battery B' at the receiving station. When the cylinders at either end of the circuit are rotated in the direction of the arrows—but not necessarily at the same rate of speed—a *fac simile* of whatever is written or drawn upon the metallic surface Fo appears upon the chemically prepared paper P.

The method by means of which the musical signals may be sent

simultaneously in both directions along the same circuit is shown in our next illustration, figures 8, 9, and 10. The arrangement is similar to that shown in figures 3, 4, and 5, excepting that the intermittent current from the transmitting instruments is passed through the primary wires of an induction coil, and the receiving instruments are placed in circuit with the secondary wire. In this way free earth communication is secured at either end of the circuit, and the musical signals produced by the manipulation of any key are received at all the stations upon the line. The great objection to this plan is the extreme complication of the parts and the necessity of employing local and main batteries at every station. It was also found by practical experiment that it was difficult, if not impossible, upon either of the plans here shown, to transmit simultaneously the number of musical tones that theory showed to be feasible. Mature consideration revealed the fact that this difficulty lay in the nature of the electrical current employed, and was finally obviated by the invention of the *undulatory* current.

It is a strange fact that important inventions are often made almost simultaneously by different persons in different parts of the world, and the idea of multiple telegraphy as developed in the preceding diagrams seems to have occurred independently to no less than four other inventors in America and Europe. Even the details of the arrangements upon circuit—shown in figures 3, 4, 5, and 8, 9, 10—are extremely similar in the plans proposed by Mr. Cromwell Varley of London, Mr. Elisha Gray of Chicago, Mr. Paul La Cour of Copenhagen, and Mr. Thomas Edison of Newark, New Jersey. Into the question of priority of invention, of course, it is not my intention to go to-night.

That the difficulty in the use of an intermittent current may be more clearly understood, I shall ask you to accompany me in my explanation of the effect produced when two musical signals of different pitch are simultaneously directed along the same circuit. Fig. 11 shows an arrangement whereby the reeds *a a'* of two transmitting instruments are caused to interrupt the current from the same battery, B. We shall suppose the musical interval between the two reeds to be a major third, in which case their

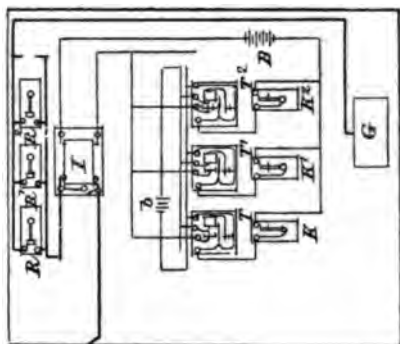

Fig. 8.

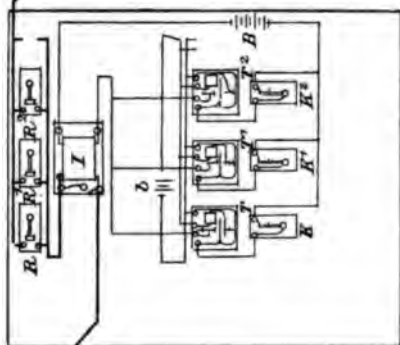

Fig. 9.

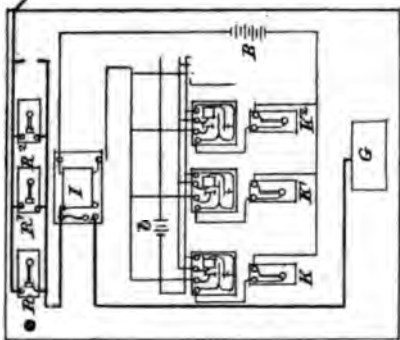

Fig. 10.

vibrations are in the ratio of 4 to 5, *i.e.*, 4 vibrations of a are made in the same time as 5 vibrations of a' . A^2 and B^2 represent the

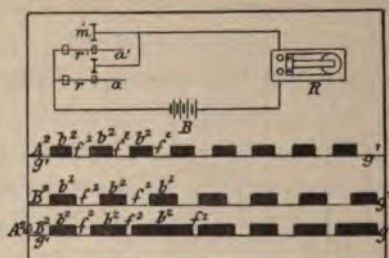

Fig. 11.

intermittent currents produced, 4 impulses of B^2 being made in the same time as 5 impulses of A^2 . The line $A^2 + B^2$ represents the resultant effect upon the main line when the reeds a and a' are simultaneously caused to make and break the same circuit, and from the illustration you will perceive that the resultant current, whilst retaining a uniform intensity, is less interrupted when both reeds are in operation than when one alone is employed. By carrying your thoughts still further you will understand that when a large number of reeds of different pitch or of different rates of vibration are simultaneously making and breaking the same circuit the resultant effect upon the main line is practically equivalent to one continuous current.

It will also be understood that the maximum number of musical signals that can be simultaneously directed along a single wire without conflict depends very much upon the ratio which the "make" bears to the "break;" the shorter the contact made, and the longer the break, the greater the number of signals that can be transmitted without confusion, and *vice versa*. The apparatus by means of which this theoretical conclusion has been verified is here to-night, and consists of an ordinary parlour harmonium, the reeds of which are operated by wind in the usual manner. In front of each reed is arranged a metal screw, against which the reed strikes in the course of its vibration. By adjusting the screw the duration

of the contact can be made long or short. The reeds are connected with one pole of a battery, and the screws against which they strike communicate with the line-wire, so that intermittent impulses from the battery are transmitted along the line-wire during the vibration of the reeds.

We now proceed to the next illustration. Without entering into

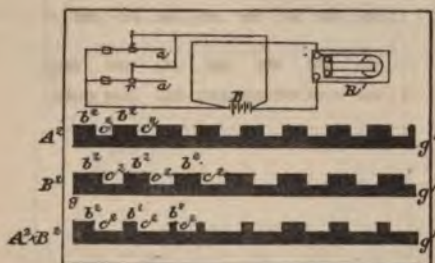

Fig. 12.

the details of the calculation you will see that with a pulsatory current the effect of transmitting musical signals simultaneously is nearly equivalent to a continuous current of minimum intensity—see $A^2 + B^2$, fig. 12; but when undulatory currents are employed the effect is different—see fig. 13. The current from the battery B is

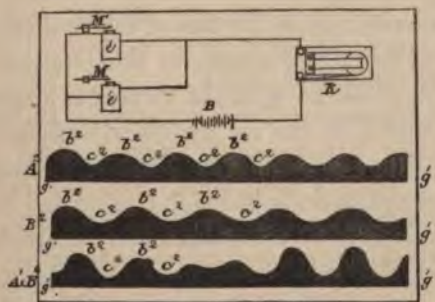

Fig. 13.

thrown into waves by the inductive action of iron or steel reeds $M M'$, vibrated in front of electro-magnets $e e'$, placed in circuit with the battery; A^2 and B^2 represent the undulations caused in the current

by the vibration of the magnetised bodies, and it will be seen that there are four undulations of B^2 in the same time as five undulations of A^2 . The resultant effect upon the main line is expressed by the curve $A^2 + B^2$, which is the algebraical sum of the sinusoidal curves A^2 and B^2 . A similar effect is produced when reversed undulatory currents are employed as shown in fig. 14, where the current is produced by the vibration of permanent magnets $M M'$ in front of electro-magnets ($e e'$), united upon a circuit without a voltaic battery. It will be understood from figs. 13 and 14 that

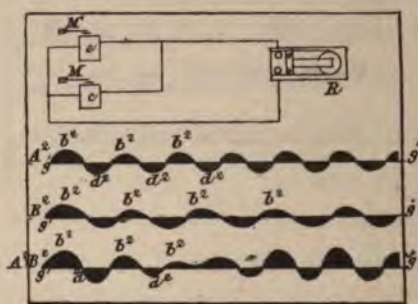

Fig. 14.

the effect of transmitting musical signals of different pitches simultaneously along a single wire is not to obliterate the vibratory character of the current as in the case of intermittent and pulsatory currents, but to change the shapes of the electrical undulations. In fact, the effect produced upon the current is precisely analogous to the effect produced in the air by the vibration of the inducing bodies $M M'$. Hence it should be possible to transmit as many musical tones simultaneously through a telegraph wire as through the air. The possibility of using undulatory currents for the purposes of multiple telegraphy enabled me to dispense entirely with the complicated arrangements of the circuit shown in figs. 3, 4, 5, and 8, 9, 10, and to employ a single battery for the whole circuit, retaining only the receiving instruments formerly shown. This arrangement is represented in figs. 15, 16, and 17. Upon vibrating the steel reed of a receiver R, R' , at any station by any mechanical means, the corresponding reeds at all the other stations are thrown

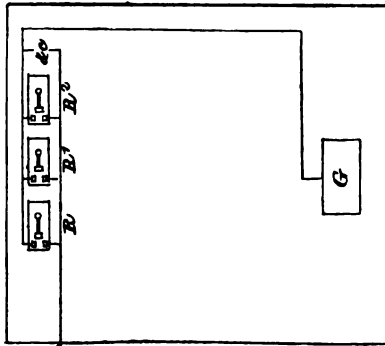

Fig. 17.

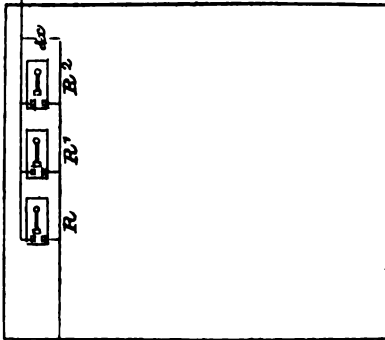

Fig. 16.

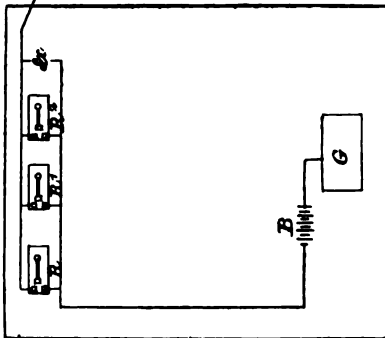

Fig. 15.

into vibration, reproducing the signal. By attaching the steel reeds to the poles of a powerful permanent magnet, as shown in fig. 19, the signals can be produced without the aid of a battery.

I have formerly stated that Helmholtz was enabled to produce vowel sounds artificially by combining musical tones of different pitches and intensities. His apparatus is shown in fig. 18. Tuning-

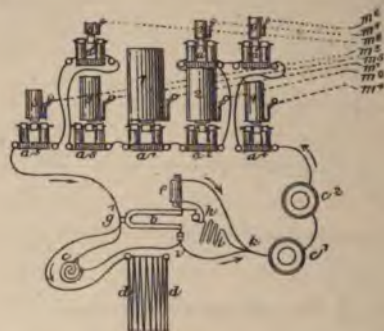

Fig. 18.*

forks of different pitch are placed between the poles of electro-magnets (a^1 , a^2 , &c.), and are kept in continuous vibration by the action of an intermittent current from the fork b . Resonators 1, 2, 3, &c. are arranged so as to reinforce the sounds, in a greater or less degree, according as the exterior orifices are enlarged or contracted.

Thus it will be seen that upon Helmholtz's plan the tuning-forks themselves produce tones of uniform intensity, the loudness being varied by an external reinforcement; but it struck me that the same results would be obtained, and in a much more perfect manner, by causing the tuning-forks themselves to vibrate with different degrees of amplitude. I therefore devised the apparatus shown in fig. 19, which was my first form of articulating telephone. In this figure a harp of steel rods is employed attached to the poles of a permanent magnet N.S. When any one of the rods is thrown into vibration an undulatory current is produced in the coils of the electro-magnet E, and the electro-magnet E' attracts the rods of

* The full description of this figure will be found in Mr. Alexander J. Ellis's translation of Helmholtz's work, "Theory of Tone."

the harp H' with a varying force, throwing into vibration that rod which is in unison with that vibrated at the other end of the circuit. Not only so, but the amplitude of vibration in the one will determine

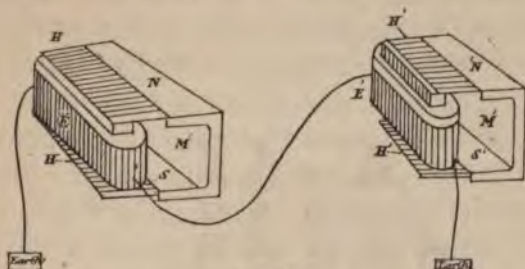

Fig. 19.

the amplitude of vibration in the other, for the intensity of the induced current is determined by the amplitude of the inducing vibration, and the amplitude of the vibration at the receiving end depends upon the intensity of the attractive impulses. When we sing into a piano, certain of the strings of the instrument are set in vibration sympathetically by the action of the voice with different degrees of amplitude, and a sound, which is an approximation to the vowel uttered, is produced from the piano. Theory shows, that, had the piano a very much larger number of strings to the octave, the vowel sounds would be perfectly reproduced. My idea of the action of the apparatus, shown in fig. 19, was this: Utter a sound in the neighbourhood of the harp H , and certain of the rods would be thrown into vibration with different amplitudes. At the other end of the circuit the corresponding rods of the harp H' would vibrate with their proper relations of force, and the *timbre* of the sound would be reproduced. The expense of constructing such an apparatus as that shown in fig. 19 deterred me from making the attempt, and I sought to simplify the apparatus before venturing to have it made.

I have before alluded to the invention by my father of a system of physiological symbols for representing the action of the vocal organs, and I had been invited by the Boston Board of Education to conduct a series of experiments with the system in the Boston school for the deaf and dumb. It is well known that deaf mutes are dumb merely because they are deaf, and that there is no defect

in their vocal organs to incapacitate them from utterance. Hence it was thought that my father's system of pictorial symbols, popularly known as visible speech, might prove a means whereby we could teach the deaf and dumb to use their vocal organs and to speak. The great success of these experiments urged upon me the advisability of devising methods of exhibiting the vibrations of sound optically, for use in teaching the deaf and dumb. For some time I carried on experiments with the manometric capsule of Koenig, and with the phonautograph of Léon Scott. The scientific apparatus in the Institute of Technology in Boston was freely placed at my disposal for these experiments, and it happened that at that time a student of the Institute of Technology, Mr. Maurey, had invented an improvement upon the phonautograph. He had succeeded in vibrating by the voice a stylus of wood about a foot in length which was attached to the membrane of the phonautograph, and in this way he had been enabled to obtain enlarged tracings upon a plane surface of smoked glass. With this apparatus I succeeded in producing very beautiful tracings of the vibrations of the air for vowel sounds. Some of these tracings are shown in fig. 20. I was much struck with this improved form of apparatus.

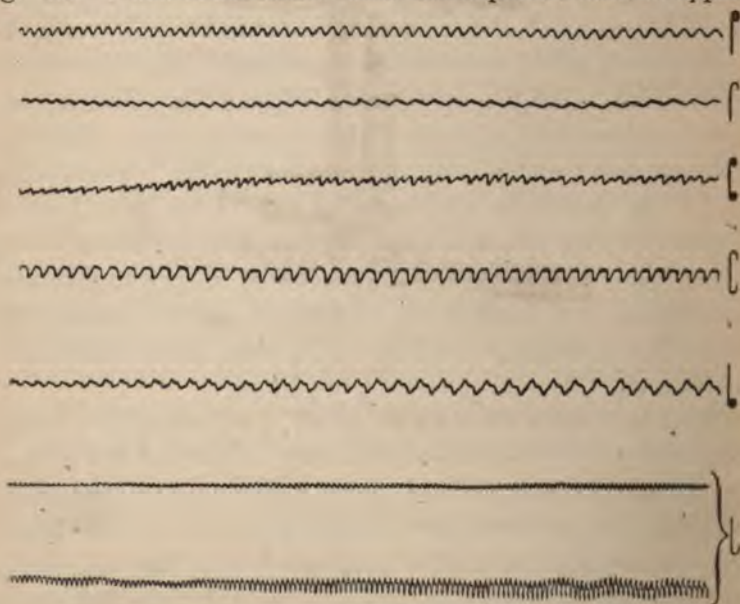

Fig. 20.

tus, and it occurred to me that there was a remarkable likeness between the manner in which this piece of wood was vibrated by the membrane of the phonautograph and the manner in which the *ossiculæ* of the human ear were moved by the tympanic membrane. I determined therefore to construct a phonautograph modelled still more closely upon the mechanism of the human ear, and for this purpose I sought the assistance of a distinguished aurist in Boston, Dr. Clarence J. Blake. He suggested the use of the human ear itself as a phonautograph, instead of making an artificial imitation of it. The idea was novel and struck me accordingly, and I requested my friend to prepare a specimen for me, which he did. The apparatus, as finally constructed, is shown in fig. 21. The

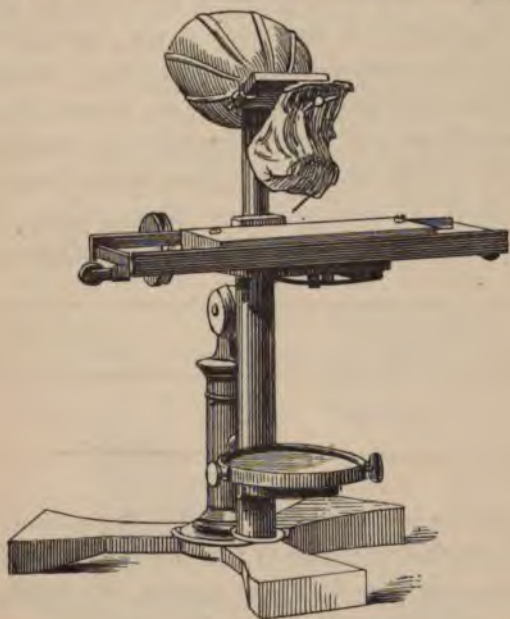

Fig. 21.

stapes was removed and a stylus of hay about an inch in length was attached to the end of the incus. Upon moistening the *membrana-tympani* and the *ossiculæ* with a mixture of glycerine and water, the necessary mobility of the parts was obtained; and upon singing into the external artificial ear the stylus of hay was thrown into vibration, and tracings were obtained upon a *claxæ*

surface of smoked glass passed rapidly underneath. While engaged in these experiments I was struck with the remarkable disproportion in weight between the membrane and the bones that were vibrated by it. It occurred to me that if a membrane as thin as tissue paper could control the vibration of bones that were, compared to it, of immense size and weight, why should not a larger and thicker membrane be able to vibrate a piece of iron in front of an electro-magnet, in which case the complication of steel rods shown in my first form of telephone, fig. 19, could be done away with, and a simple piece of iron attached to a membrane be placed at either end of the telegraphic circuit.

Fig. 22 shows the form of apparatus that I was then employing for producing undulatory currents of electricity for the purposes of multiple telegraphy. A steel reed *A* was clamped firmly by one extremity to the uncovered leg *h* of an electro-magnet *E*, and the free end of the reed projected above the covered leg. When the reed *A* was vibrated in any mechanical way, the battery current was thrown into waves, and electrical undulations traversed the circuit *B E W E'*, throwing into vibration the corresponding reed *A'* at the other end of the circuit. I immediately proceeded to

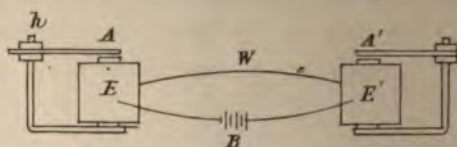

Fig. 22.

put my new idea to the test of practical experiment, and for this purpose I attached the reed *A* (fig. 23) loosely by one extremity to the uncovered pole *h* of the magnet, and fastened the other

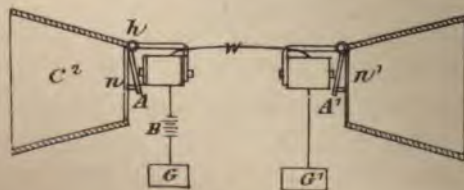

Fig. 23.

extremity to the centre of a stretched membrane of goldbeaters' skin n . I presumed that upon speaking in the neighbourhood of the membrane n it would be thrown into vibration and cause the steel reed A to move in a similar manner, occasioning undulations in the electrical current that would correspond to the changes in the density of the air during the production of the sound; and I further thought that the change of the intensity of the current at the receiving end would cause the magnet there to attract the reed A' in such a manner that it should copy the motion of the reed A , in which case its movements would occasion a sound from the membrane n' similar in *timbre* to that which had occasioned the original vibration.

The results, however, were unsatisfactory and discouraging. My friend Mr. Thomas A. Watson, who assisted me in this first experiment, declared that he heard a faint sound proceed from the telephone at his end of the circuit, but I was unable to verify his assertion. After many experiments attended by the same only partially-successful results, I determined to reduce the size and weight of the spring as much as possible. For this purpose I glued a piece of clock spring, about the size and shape of my thumbnail, firmly to the centre of the diaphragm, and had a similar instrument at the other end (fig. 24); we were then enabled to obtain distinctly audible effects. I remember an experiment made with this tele-

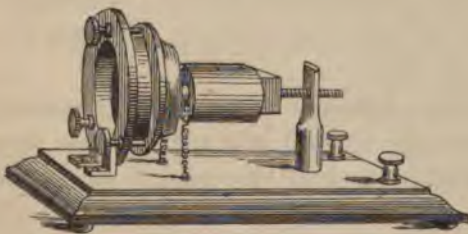

Fig. 24.

phone, which at the time gave me great satisfaction and delight. One of the telephones was placed in my lecture-room in the Boston University, and the other in the basement of the adjoining building. One of my students repaired to the distant telephone to observe the effects of articulate speech, while I uttered the sentence, "Do you understand what I say?" into the telephone placed in the lecture-

hall. To my delight an answer was returned through the instrument itself, articulate sounds proceeded from the steel spring attached to the membrane, and I heard the sentence, "Yes, I understand you perfectly." It is a mistake, however, to suppose that the articulation was by any means perfect, and expectancy no doubt had a great deal to do with my recognition of the sentence; still, the articulation was there, and I recognised the fact that the



Fig. 25.

indistinctness was entirely due to the imperfection of the instrument. I will not trouble you by detailing the various stages through which the apparatus passed, but shall merely say that after a time I produced the form of instrument shown in fig. 25, which served very well as a receiving telephone. In this condition my invention was exhibited at the Centennial Exhibition in Philadelphia. The telephone shown in fig. 24 was used as a transmitting instrument, and that in fig. 25 as a receiver, so that vocal communication was only established in one direction.

Another form of transmitting telephone exhibited in Philadelphia intended for use with the receiving telephone (fig. 25) is represented by fig. 26.

A platinum wire attached to a stretched membrane completed a voltaic circuit by dipping into water. Upon speaking to the membrane, articulate sounds proceeded from the telephone in the distant room. The sounds produced by the telephone became louder when dilute sulphuric acid, or a saturated solution of salt, was substituted for the water. Audible effects were also produced by the vibration of plumbago in mercury, in a solution of bichromate of potash, in salt and water, in dilute sulphuric acid, and in pure water.

The articulation produced from the instrument shown in fig. 25 was remarkably distinct, but its great defect consisted in the fact that it could not be used as a transmitting instrument, and thus

two telephones were required at each station, one for transmitting and one for receiving spoken messages.

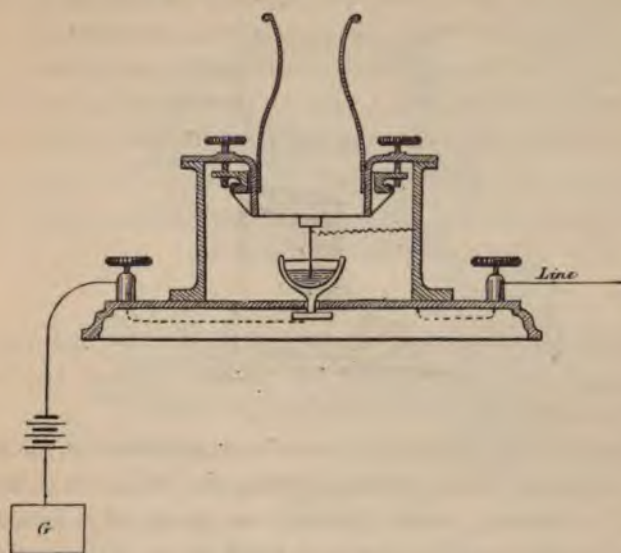

Fig. 26.

It was determined to vary the construction of the telephone shown in fig. 24, and I sought by changing the size and tension of the membrane, the diameter and thickness of the steel spring, the size and power of the magnet, and the coils of insulated wire around their poles, to discover empirically the exact effect of each element of the combination, and thus to deduce a more perfect form of apparatus. It was found that a marked increase in the loudness of the sounds resulted from shortening the length of the coils of wire, and by enlarging the iron diaphragm which was glued to the membrane. In the latter case, also, the distinctness of the articulation was improved. Finally, the membrane of gold-beaters' skin was discarded entirely, and a simple iron plate was used instead, and at once intelligible articulation was obtained. The new form of instrument is that shown in fig. 27, and, as had been long anticipated, it was proved that the only use of the battery was to magnetize the iron core of the magnet, for the effects were equally audible when the battery was omitted and a rod of magnetized steel substituted for the iron core of the magnet.

It was my original intention, as shown in fig. 19, and it was always claimed by me, that the final form of telephone would be

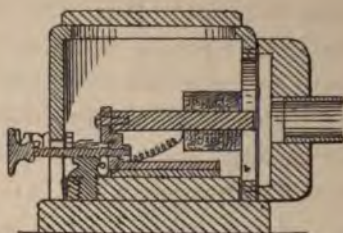

Fig. 27.

operated by permanent magnets in place of batteries, and numerous experiments had been carried on by Mr. Watson and myself privately for the purpose of producing this effect.

At the time the instruments were first exhibited in public the results obtained with permanent magnets were not nearly so striking as when a voltaic battery was employed, wherefore we thought it best to exhibit only the latter form of instrument.

The interest excited by the first published accounts of the operation of the telephone led many persons to investigate the subject, and I doubt not that numbers of experimenters have independently discovered that permanent magnets might be employed instead of voltaic batteries. Indeed one gentleman, Professor Dolbear, of Tufts College, not only claims to have discovered the magneto-electric telephone, but I understand charges me with having obtained the idea from him through the medium of a mutual friend.

A still more powerful form of apparatus was constructed by using a powerful compound horse-shoe magnet in place of the straight rod which had been previously used (see fig. 28). Indeed

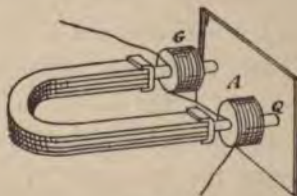

Fig. 28.

the sounds produced by means of this instrument were of sufficient loudness to be faintly audible to a large audience, and in this condition the instrument was exhibited in the Essex Institute, in Salem, Massachusetts, on the 12th Feb. 1877, on which occasion a short speech shouted into a similar telephone in Boston, sixteen miles away, was heard by the audience in Salem. The tones of the speaker's voice were distinctly audible to an audience of 600 people, but the articulation was only distinct at a distance of about 6 feet. On the same occasion, also, a report of the lecture was transmitted

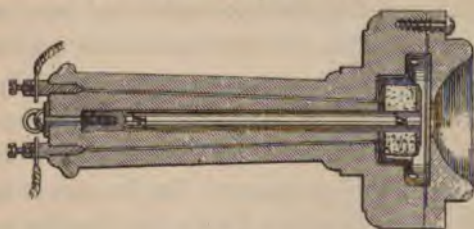

Fig. 29.

by word of mouth from Salem to Boston, and published in the papers the next morning.

From the form of telephone shown in fig. 27 to the present form of the instrument (fig. 29) is but a step. It is in fact the arrangement of fig. 27 in a portable form, the magnet F H being placed inside the handle and a more convenient form of mouthpiece provided. The arrangement of these instruments upon a telegraphic circuit is shown in fig. 30.

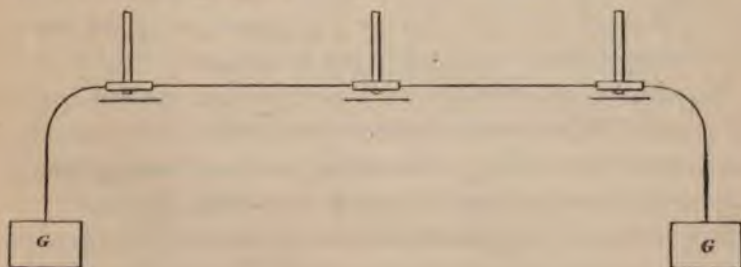

Fig. 30.

And here I wish to express my indebtedness to several scientific friends in America for their co-operation and assistance.

I would specially mention Professor Peirce and Professor Blake, of Brown University, Dr. Channing, Mr. Clarke, and Mr. Jones. In Providence, Rhode Island, these gentlemen have been carrying on together experiments seeking to perfect the form of apparatus required, and I am happy to record the fact that they communicated to me each new discovery as it was made, and every new step in their investigations. It was, of course, almost inevitable that these gentlemen should retrace much of the ground that had been gone over by me, and so it has happened that many of their discoveries had been anticipated by my own researches; still, the very honourable way in which they from time to time placed before me the results of their discoveries entitles them to my warmest thanks and to my highest esteem. It was always my belief that a certain ratio would be found between the several parts of a telephone, and that the size of the instrument was immaterial; but Professor Peirce was the first to demonstrate the extreme smallness of the magnets which might be employed. And here, in order to show the parallel lines in which we were working, I may mention the fact that two or three days after I had constructed a telephone of the portable form (fig. 29), containing the magnet inside the handle, Dr. Channing was kind enough to send me a pair of telephones of a similar pattern, which had been invented by the Providence experimenters. The convenient form of mouthpiece shown in fig. 29, now adopted by me, was invented solely by my friend Professor Peirce. I must also express my obligations to my friend and associate, Mr. Thomas A. Watson, of Salem, Massachusetts, who has for two years past given me his personal assistance in carrying on my researches.

In pursuing my investigations I have ever had one end in view, the practical improvement of electric telegraphy; but I have come across many facts which, while having no direct bearing upon the subject of telegraphy, may yet possess an interest for you.*

For instance, I have found that a musical tone proceeds from a piece of plumbago or retort-carbon when an intermittent current of

* See *Researches in Telephony*.—Trans. of American Acad. of Arts and Sciences, vol. xii. p. 1.

electricity is passed through it, and I have observed the most curious audible effects produced by the passage of reversed intermittent currents through the human body. A rheotome was placed in circuit with the primary wires of an induction coil, and the fine wires were connected with two strips of brass. One of these strips was held closely against the ear, and a loud sound proceeded from it whenever the other slip was touched with the other hand. The strips of brass were next held one in each hand. The induced currents occasioned a muscular tremor in the fingers. Upon placing my forefinger to my ear a loud crackling noise was audible, seemingly proceeding from the finger itself. A friend who was present placed my finger to his ear, but heard nothing. I requested him to hold the strips himself. He was then distinctly conscious of a noise (which I was unable to perceive) proceeding from his finger. In this case a portion of the induced currents passed through the head of the observer when he placed his ear against his own finger: and it is possible that the sound was occasioned by a vibration of the surfaces of the ear and finger in contact.

When two persons receive a shock from a Ruhmkorff's coil by clasping hands, each taking hold of one wire of the coil with the free hand, a sound proceeds from the clasped hands. The effect is not produced when the hands are moist. When either of the two touches the body of the other a loud sound comes from the parts in contact. When the arm of one is placed against the arm of the other, the noise produced can be heard at a distance of several feet. In all these cases a slight shock is experienced so long as the contact is preserved. The introduction of a piece of paper between the parts in contact does not materially interfere with the production of the sounds, but the unpleasant effects of the shock are avoided.

When an intermittent current from a Ruhmkorff's coil is passed through the arms a musical note can be perceived when the ear is closely applied to the arm of the person experimented upon. The sound seems to proceed from the muscles of the fore-arm and from the biceps muscle. Mr. Elisha Gray* has also produced audible effects by the passage of electricity through the human body.

* *Elisha Gray*. Eng. Pat. Spec. No. 2646, Aug. 1874.

An extremely loud musical note is occasioned by the spark of a Ruhmkorff's coil when the primary circuit is made and broken with sufficient rapidity; when two rheotomes of different pitch are caused simultaneously to open and close the primary circuit a double tone proceeds from the spark.

A curious discovery, which may be of interest to you, has been made by Professor Blake. He constructed a telephone in which a rod of soft iron, about six feet in length, was used instead of a permanent magnet. A friend sang a continuous musical tone into the mouthpiece of a telephone, like that shown in fig. 29, which was connected with the soft iron instrument alluded to above. It was found that the loudness of the sound produced in this telephone varied with the direction in which the iron rod was held, and that the maximum effect was produced when the rod was in the position of the dipping-needle. This curious discovery of Professor Blake has been verified by myself.

When a telephone is placed in circuit with a telegraph line, the telephone is found seemingly to emit sounds on its own account. The most extraordinary noises are often produced, the causes of which are at present very obscure. One class of sounds is produced by the inductive influence of neighbouring wires and by leakage from them, the signals of the Morse alphabet passing over neighbouring wires being audible in the telephone, and another class can be traced to earth currents upon the wire, a curious modification of this sound revealing the presence of defective joints in the wire.

Professor Blake informs me that he has been able to use the railroad track for conversational purposes in place of a telegraph-wire, and he further states that when only one telephone was connected with the track the sounds of Morse operating were distinctly audible in the telephone, although the nearest telegraph-wires were at least forty feet distant.

Professor Peirce has observed the most curious sounds produced from a telephone in connection with a telegraph-wire during the aurora borealis; and I have just heard of a curious phenomenon lately observed by Dr. Channing. In the city of Providence, Rhode Island, there is an overhouse wire about one mile in extent

with a telephone at either end. On one occasion the sound of music and singing was faintly audible in one of the telephones. It seemed as if some one were practising vocal music with a piano-forte accompaniment. The natural supposition was that experiments were being made with the telephone at the other end of the circuit, but upon inquiry this proved not to have been the case. Attention having thus been directed to the phenomenon, a watch was kept upon the instruments, and upon a subsequent occasion the same fact was observed at both ends of the line by Dr. Channing and his friends. It was proved that the sounds continued for about two hours, and usually commenced about the same time. A searching examination of the line disclosed nothing abnormal in its condition, and I am unable to give you any explanation of this curious phenomenon. Dr. Channing has, however, addressed a letter upon the subject to the editor of one of the Providence papers, giving the names of such songs as were recognised, with full details of the observations, in the hope that publicity may lead to the discovery of the performer, and thus afford a solution of the mystery.*

My friend Mr. Frederick A. Gower communicated to me a curious observation made by him regarding the slight earth connection required to establish a circuit for the telephone, and together we carried on a series of experiments with rather startling results. We took a couple of telephones and an insulated wire about 100 yards in length into a garden, and were enabled to carry on conversation with the greatest ease when we held in our hands what should have been the earth wire, so that the connection with the ground was formed at either end through our bodies, our feet being clothed with cotton socks and leather boots. The day was fine, and the grass upon which we stood was seemingly perfectly dry. Upon standing upon a gravel walk the vocal sounds, though much diminished, were still perfectly intelligible, and the same result occurred when standing upon a brick wall one foot in height, but no sound was audible when one of us stood upon a block of freestone.

One experiment which we made is so very interesting that I

* For the explanation of this phenomenon, see letter from Dr. Channing in the Appendix.

must speak of it in detail. Mr. Gower made earth connection at his end of the line by standing upon a grass plot, whilst at the other end of the line I stood upon a wooden board. I requested Mr. Gower to sing a continuous musical note, and to my surprise the sound was very distinctly audible from the telephone in my hand. Upon examining my feet I discovered that a single blade of grass was bent over the edge of the board, and that my foot touched it. The removal of this blade of grass was followed by the cessation of the sound from the telephone, and I found that the moment I touched with the toe of my boot a blade of grass or the petal of a daisy the sound was again audible.

The question will naturally arise, Through what length of wire can the telephone be used? In reply to this I may say that the maximum amount of resistance through which the undulatory current will pass, and yet retain sufficient force to produce an audible sound at the distant end, has yet to be determined; no difficulty has, however, been experienced in laboratory experiments in conversing through a resistance of 60,000 ohms, which has been the maximum at my disposal. On one occasion, not having a rheostat at hand, I may mention having passed the current through the bodies of sixteen persons, who stood hand in hand. The longest length of real telegraph line through which I have attempted to converse has been about 250 miles. On this occasion no difficulty was experienced so long as parallel lines were not in operation. Sunday was chosen as the day on which it was probable other circuits would be at rest. Conversation was carried on between myself, in New York, and Mr. Thomas A. Watson, in Boston, until the opening of business upon the other wires. When this happened the vocal sounds were very much diminished, but still audible. It seemed, indeed, like talking through a storm. Conversation though possible could be carried on with difficulty, owing to the distracting nature of the interfering currents.

I am informed by my friend Mr. Preece that conversation has been successfully carried on through a submarine cable, sixty miles in length, extending from Dartmouth to the Island of Guernsey, by means of hand telephones similar to that shown in fig. 30.

The PRESIDENT: Very few in this room I am sure will regret

that but little time is left for the discussion of the vast mass of interesting information brought before us by Professor Bell. It must have been the lot of very few of those present to have listened before to so beautiful, so philosophical, a series of researches, so lucidly and perfectly brought before an audience. No doubt a multitude of questions will arise in the minds of those who have given thought to this and kindred subjects which they would like to put. Time will, however, only permit a limited discussion, and I will ask gentlemen who have any questions to put, or observations to make, to do so in as brief and succinct a manner as possible. We shall be glad to hear the opinions of men eminent for their knowledge of physical science, of whom there are many in the room.

Mr. LATIMER CLARK: I am permitted by the President to have the honour of proposing a vote of thanks to Professor Bell for the very lucid and charming discourse we have heard this evening. There has never been a subject brought before us since my connection with this Society, and that is from its beginning, so interesting or so important as the one we have heard this evening, or one which will form a greater epoch in the history of electricity. It seems as if we had reached the culminating point of Electric Telegraphy. I have the more pleasure in proposing this vote inasmuch as Professor Bell is a countryman of ours; but the invention nevertheless is really from America, and it is important for us to note that two or three of the most important recent electrical inventions have come to us from the other side of the Atlantic. I allude to multiplex and duplex telegraphy, and telegraphy by sound. It behoves us therefore to look to our laurels or we shall find ourselves falling behind. Great discoveries often cast their shadows before them, and, in the light of our present knowledge, it will I am sure interest you if I read a rather curious notice of a proposed telephone which was published about twenty years ago in a work of the Comte Th. Du Moncel, entitled *Exposé des applications de l'électricité*. Paris, 1857. The writer is a certain M. Ch. B . . . , and it is interesting to see how clearly he depicted the results at which Professor Bell has arrived to-day.

Du Moncel says,—“Electrical Transmission of Speech—I have not thought it desirable to give prominence in this chapter on the

Electric Telegraph to a fantastic idea of a certain M. Ch. B who believes that we shall be able to transmit speech by electricity, for it might be asked why I class amongst so many remarkable inventions an idea which is at present only a dream of its author. Nevertheless, as I am bound to be faithful to the duty I have undertaken of mentioning every electrical application which has come to my knowledge, I will give you some details which the author has already published on this subject. He says, 'I ask myself, for example, if words themselves cannot be transmitted by electricity; in other words, if one could not speak at Vienna and make oneself heard in Paris—the thing is practicable and I will show you how.

'Imagine that you speak against a sensitive plate so flexible as to lose none of the vibrations produced by the voice, and that this plate makes and breaks successively the communication with an electric pile; you may have at any distance another plate, which will undergo in the same time the same vibrations.

'It is obvious that numberless applications of high importance would immediately arise out of the transmission of speech by electricity; any one who was not deaf and dumb could make use of this mode of transmission, which would not require any kind of apparatus—an electric pile, two vibratory plates, and a metallic wire, are all that would be necessary.

'In any case it is certain that in a future, more or less distant, speech will be transmitted to a distance by electricity. I have commenced experiments with this object; they are delicate and require time and patience for their development, but the approximations already obtained give promise of a favourable result."

The dream of yesterday has become the reality of to-day. The ideas are essentially different, but it is nevertheless a very singular and interesting prevision of the instrument we have had the pleasure of hearing described this evening by Professor Bell. There are doubtless many who would like to avail themselves of the use of this instrument. I have made a few experiments on it myself, and find it is practically impossible to speak through the ordinary street wires of London on account of the numberless currents which are passing through neighbouring wires, the signals of which produce a sound very like a noise of a hailstorm. This difficulty

can be overcome; but underground wires are expensive, and their employment would gradually limit the practical application of the system in London. I have lately had occasion to apply for permission to erect overground wires, and I find there is much difficulty in establishing them in London on account of the opposition manifested by private individuals and parochial authorities, and by the Board of Trade. This feeling is caused by the serious accidents which have occurred through the falling of overground wires and the fatal injuries which have followed in more than one case. Overground wires are especially suited for the telephone, and it therefore behoves us as electricians to turn our attention to the subject, and to find out some system of overground communication which will be free from danger, and at the same time will not be objected to by the authorities. I will make no further remarks, but beg to move a cordial vote of thanks to Professor Bell for his deeply interesting discourse.

—Mr. W. H. PREECE. It is my especial pleasure to second the proposition that has been made by Mr. Latimer Clark. (This is not the first time I have heard Professor Bell describe this beautiful invention of his. A few months ago I had the pleasure of meeting him in America, and he took me through his own laboratory in Boston, where I saw all the apparatus that has been described to you to-night, and where he showed me, step by step, the progress he had made, from the first incipient idea to this simple little instrument which I now hold in my hand. The paragraph that Mr. Latimer Clark has read is remarkably interesting, and the suggestion of Du Moncel's is very pretty, but it wants the egg to be broken to make the thing practicable and workable. Were it not for the unique and exquisite discovery of Professor Bell, the shadowed-forth telephone of Du Moncel would be absolutely and practically impossible.

Now the particular principle that Professor Bell has discovered is the fact, that, as you vibrate a plate of iron in front of a magnet surrounded by a coil of wire, you produce currents of electricity in that coil, which vary in their strength directly as the rate with which the plate of iron moves. Thus we have a means of producing the motion of other plates by attractions which vary directly with the

motion with which the molecules of air vibrate when set in undulation by the voice, and thus a means of reproducing sound, however it may vary in pitch, loudness, and quality. This marks an epoch in the history of electricity, and it is impossible to say what this infant which I hold in my hand may in future bring forth.

While on the one part Professor Bell has placed in our hands, to a certain extent, a new power, he has, on the other hand, thrown upon our shoulders an extra weight. The poor telegraph engineer has now to master many sciences. Not only must he know something of electricity and magnetism, not only must he know a good deal of chemistry, not only must he pass through various stages of mathematical knowledge, but now—thanks to Professor Bell—he is obliged to be master of the intricacies of acoustics. I do not blame him, because the study of sound is in itself a beautiful occupation, and when it becomes linked to one's profession it becomes almost a luxury. We now find, by the aid of these new undulatory currents, that the energy of the voice is transported, first, into vibratory motion, then into electric currents, then into vibration again, and lastly into sounds once more, similar exactly to their first form. Indeed, as a distinguished American lawyer has said, "the roast beef of yesterday is electricity to-morrow, through the intervention of the human muscles and the human voice."

Professor Bell alluded to the fact that expectancy led him in his first telephone to anticipate what was said. I will give you an illustration of the effect of expectancy. It was my pleasure on a recent occasion to exhibit the telephone before a very large audience. Many learned men were present. There is one very remarkable feature of a learned meeting. When you call upon a learned member to make a learned remark he frequently makes a foolish one. (Laughter.) Now, I selected, perhaps, one of the leading scientific men of the day, and I placed the telephone in his hand. It was in connection with a similar instrument 55 miles away. Of course we expected to hear from him some learned axiom, some sage aphorism, or some wonderful statement: but after some hesitation he said, "Hey diddle diddle—follow up that." (Laughter.) He rapidly put the telephone up to his ear, and he

said with much glee, "He says Cat and the fiddle." Fifty miles off my assistant was answering the question. I asked him next day if he understood "Hey diddle diddle." He said "No." "What did you say." "I asked him to repeat." (Loud laughter.) I will not occupy your time with my own experience with this wonderful instrument. I have spoken through 30, 40, and 50 miles, and I could say a good deal about it, but I refrain from doing so at this late hour. I will simply second the proposition of Mr. Latimer Clark, that we return our heartfelt thanks to Professor Bell for the truly philosophical discourse he has given us to-night.

The PRESIDENT: It is scarcely necessary for me formally to put this proposition to the meeting, but I will ask those in favour of it to hold up their hands.

Professor Bell, allow me on behalf of this Institution to thank you very cordially for the very admirable account you have given us of your philosophical invention, and of the practical results already achieved by it, and to express the hope that these may speedily be multiplied, and that we shall shortly hear of its further achievements. (Applause.)

PROFESSOR BELL: I will not take up your time in making any reply to the very cordial vote of thanks that has been given to me, but will merely thank you very sincerely for your attention and for your kindness.

The meeting was then adjourned.

The Sixtieth Ordinary General Meeting was held on Wednesday, the 28th November, 1877. Professor ABEL, C.B., F.R.S., President, in the Chair.

The PRESIDENT: Members of the Society are aware that the time is approaching when, according to ordinary usage, they should meet together at the annual *soirée*, which is always one of the most agreeable meetings of the year. The Council have carefully considered the question of the *soirée*, and while they, and I myself, were most anxious that the Members should meet thus as usual, it was thought on mature deliberation it would be advantageous to the Society to propose that the usual *soirée* should be deferred for a time, for this reason, that next year the Members of the International Telegraph Conference will meet together in London, and it was felt that the Society of Telegraph Engineers should endeavour to exert themselves on that occasion to give the best possible welcome to the Members of that Conference, and to contribute to make their visit to London as interesting as possible: and hence it is thought that the Members will agree with the view of the Council on this point, viz., that it will be desirable to husband our resources with the view to giving the Members of the Conference a welcome and reception worthy of the event. (Hear, hear.) It is therefore proposed that the ordinary *soirée* of the Society should be postponed till next year, in order that the Members of the Conference may be invited by the Society to an entertainment to be given on a scale commensurate with the occasion, the expense of which will be met, as far as may be, out of the funds of the Society, but aided by the voluntary subscriptions of Members. It is proposed that the *soirée* on that occasion should be on a larger and more interesting scale than ordinary, and it is hoped that the Council will receive the support and concurrence of the Members at large in this matter. (Hear, hear.) In opening this, the first ordinary meeting of the Society at the commencement of the Session, it is hardly necessary to remind Members that we have already had one interesting, though an extraordinary, *meeting*, at which Professor Graham Bell was so good as to favour us

with a lucid account of the development of the Telephone. We now meet in the first ordinary meeting, and before proceeding to the business of the meeting and of the session, which I hope and believe will be as successful as those which have preceded it, it is my sad duty to refer to the loss which the Society has sustained by the death of one its members, Major-General David Robinson, Director-General of Telegraphs in India, who died last July. The services of Major-General Robinson are so well known, not only in connection with telegraphy generally but more especially with the progress of the telegraph in India, that I need only refer to them to recall them to the memory of the Members of this Society. He was a man universally respected, not only as a brave soldier, as a very intelligent man, and as a most able and active director of the department over which he was placed, but also as a great friend to all who worked under him as their chief; and his loss cannot but be generally deplored by the Members of this Society. I now beg to call upon Mr. Willoughby Smith to read his paper "On Selenium, its electrical qualities and the effect of light thereon."

"SELENIUM," ITS ELECTRICAL QUALITIES AND THE EFFECT OF LIGHT THEREON.

By WILLOUGHBY SMITH.

FROM the many inquiries which have reached me since I first called attention to the effect of light upon the electrical qualities of Selenium, I am induced to enter more fully into details than I otherwise should have done.

In 1817 Berzelius discovered a new and rare elementary substance, which he named Selenium. It is obtained in small quantities from iron and copper pyrites, the smoke from the furnaces of silver works, the deposit in the leaden chambers at sulphuric-acid works, and it has also been discovered in the metallic copper of commerce. It appears in two modifications, one soluble and the other insoluble, in bisulphide of carbon. That soluble in bisulphide of carbon has been called "Red Selenium," "Amorphous Selenium," and "Glassy Selenium." That insoluble in bisulphide of carbon has been called "Black Selenium," "Granular Selenium,"

“Metallic Selenium,” and “Crystalline Selenium.” Solid amorphous Selenium is a bad conductor of heat and a non-conductor of electricity. At the ordinary temperature it remains unchanged for years. It is brittle, easily scratched, and powdered; its surface red-brown, and of a metallic lustre, and its fracture of a brown-glass colour, dark lead-grey, and shining.

Solid “Crystallized” Selenium is a conductor of electricity, has a granular lead-grey surface, and a finely granular dull fracture. The change from the “Amorphous” to the “Crystalline” state is effected by exposure to a high temperature. Requiring some bars of “Crystalline” Selenium for high resistances, I obtained seventeen from a gentleman who had previously supplied me with similar bars, but, not requiring them for immediate use, I embraced the opportunity to experiment with them, and the results are such that I hope they will prove at least interesting to the members of this Society.

The bars were placed in a wooden box thirteen and a half inches long, six inches wide, and one inch deep, with vulcanite sides and wooden cover. Through each side of the box the ends of nineteen binding-screws projected. The ends of each bar had a short length of fine brass wire in metallic contact with it. Each bar was suspended in the box by the brass wires being attached to the ends of the two binding-screws entering the box opposite each other. These bars were marked consecutively from A to R, omitting J, and their dimensions were as given in Table I.

TABLE I.

Mark.	Diameter in inches.	Length in inches.
A	·092	1·5
B	·093	1·817
C	·092	1·55
D	·066	1·433
E	·096	1·8
F	·093	1·467
G	·095	1·3
H	·092	1·917
I	·094	1·833

TABLE 1—*continued.*

Mark.	Diameter in inches.	Length in inches.
K	·066	1·667
L	·066	1·017
M	·092	1·567
N	·091	1·783
O	·094	1·967
P	·092	1·783
Q	·066	1·117
R	·091	2·483

Not one of the bars was uniform in diameter throughout its length. Several measurements of each were made, and the mean recorded. The temperature inside the box was ascertained firstly by a standard thermometer, the bulb of which was placed in the centre of the box under the bars, and the tube of which projected through an aperture at one end of the box; and, secondly, by the resistance of a length of silk-covered copper wire, which was distributed over the bottom of the box, with its ends attached to terminals, one on each side of the box. The length of the wire was so adjusted that its resistance should be one hundred ohms, while the thermometer registered 63° Fahrenheit. The room in which the experiments were made was $15 \times 16.5 \times 10$ feet. The table in the centre of the room was 8.9×4 feet. All solar light was excluded, and the room was but dimly lighted by one ordinary "fish-tail" gas burner, suspended four feet above the centre of the table. The box containing the bars was so placed on the table that the light fell on the centre of it at an angle of fifty degrees. The resistance of each bar was ascertained by the deflection method; that is, a deflection was obtained from a constant electromotive force passing through a known resistance, and then the known resistance was replaced by the Selenium bar, and the deflection noted; and from these two measures the resistance of the bar was determined. One hundred Minotto cells, having a resistance of twenty ohms per cell, were used, and an astatic mirror reflecting galvanometer, the resistance of the coils of which was 6,200 ohms. The box had been closed for three hours pre-

vious to the commencement of the test. Table 2 gives the resistance of each bar in megohms when light was excluded and when light was admitted.

TABLE 2.

Mark.	Megohms.	
	Light excluded.	Light admitted.
A	303·6	211·4
B	4·385	4·172
C	229·3	163·
D	46·43	34·44
E	591·3	370·
F	281·	197·3
G	667·	361·5
H	27·86	21·62
I	31·05	26·16
K	52·33	41·
L	739·9	535·1
M	61·10	42·09
N	47·83	34·31
O	150·3	119·9
P	19·17	17·54
Q	0·0099	0·0082
R	0·002919	0·002923
A	303·6	199·8

Each reading was taken after the current had been on one minute, commencing with the bar marked A and proceeding consecutively to the one marked R.

During the test with the light excluded the temperature increased from 61° to 63° Fahr. but this appears not to have interfered with the values, as on the completion of the test the bar marked A was re-tested and its resistance was precisely the same as at first. During the test while the light was admitted the temperature increased from 63° to 65°, and on re-testing the bar marked A its resistance had fallen to 199·8. This, however, was not all due to change of temperature, but to the time it had been exposed to the light. The effect of light is gradual, and the lower its intensity the slower its effects.

It will be seen that the resistance of each bar is lower while

under the influence of light, with the exception of the bar marked R, and that appears to have increased, but its resistance was too low to give satisfactory results, and therefore no reliance is placed in any values obtained from it. There being such great discrepancies in the resistance of the bars, the gentleman who supplied them was asked if he could assign any cause for it. He replied that they were all made from the same sample, and that probably the difference in their resistance was due to some of them having been heated longer than others. The two following tests were made with a view to ascertain the effects of difference of temperature on their electrical resistance. The box containing the bars was covered with an iron case 17.5 inches high, in the top of which was a square aperture large enough to admit the light from a "bat's-wing" gas burner suspended immediately over it, and so regulated as to keep the temperature as near 100° Fahr. as possible. The connections could be made and the light admitted or excluded by manipulating the lid of the box, without removing the iron case or in any way interfering with the arrangements.

The temperature had been kept at 100° Fahr. for an hour before the commencement of the test. The results are given in Table 3.

TABLE 3.

Mark.	Megohms.	
	Light excluded.	Light admitted.
A	373.1	183.4
B	4.719	4.185
C	283.1	152.8
D	51.75	33.19
E	633.3	287.4
F	320.9	163.7
G	654.9	237.7
H	42.97	26.59
I	31.67	24.81
K	48.62	35.65
L	687.6	377.5
M	92.56	46.06
N	65.04	33.78
O	123.4	78.90
P	11.19	8.997

TABLE 3—*continued.*

Mark.	Megohms.	
	Light excluded.	Light admitted.
Q	·1449	·1318
R	·003105	·003156
A	356·5	162·6

During the test while the light was excluded the temperature gradually increased from 97° to 100° Fahr., and the resistance of bar A decreased from 373·1 to 356·5. During the test while the light was admitted the temperature increased from 98·5° to 99° and the resistance of bar A decreased from 183·4 to 162·6 megohms. Seven days intervened before the following test was made, the box having been kept closed during that time. The arrangements were the same as in the previous test with the exception that the bottom of the iron case was kept standing in a freezing mixture. The temperature was kept at 44° Fahr. for one hour before commencing the test. The results are given in Table 4.

TABLE 4.

Mark.	Megohms.	
	Light excluded.	Light admitted.
A	406·2	131·
B	5·731	5·014
C	291·7	110·7
D	54·09	27·57
E	758·1	213·5
F	353·9	122·3
G	962·7	194·5
H	29·90	18·16
I	36·06	22·92
K	61·32	35·39
L	934·7	367·5
M	69·76	30·86
N	52·90	25·74
O	188·8	85·96
P	25·67	16·60
Q	·150430	·120340
R	·003106	·003136
A	406·2	133·7

During the time occupied by the tests while the light was excluded the temperature increased from 43.7° to 46° , but the resistance of bar A remained constant, and was precisely the same on completion as at the commencement of the test. During the time occupied by the test while the light was admitted the temperature increased from 51.5° to 59.5° , and the resistance of bar A increased from 131 to 133.7 megohms.

It will be seen that at the low temperature light has a much greater effect in reducing the resistance of most of the bars than it has at the highest temperature. After the above experiments the bars were excluded from light for twenty-four hours, and then again tested under the following conditions. The box containing the bars was placed on a wooden frame two feet four inches high, in a yard sixteen feet wide, bounded on the south by the wall of a high building, and on the north by a similar wall, but not quite so high. The east and west aspects were comparatively open. The longitudinal position of the bars was north and south. The weather was what in common parlance would be termed "a dull cold afternoon." There was a light breeze from the north-east, dirty white coloured clouds were comparatively stationary over head, but in the west were gathering large clouds resembling in appearance and density the atmosphere generally seen rising from large manufacturing towns. The sun was not visible, but the varying density of its light, caused by the clouds passing between it and the bars, was distinctly marked by the alteration in the electrical resistance of the bar under test at the time. To be sure, on this point, a small artificial cloud, made of finely-combed wadding, was passed from north to south about two feet from and at an angle above the box. Although it was difficult to perceive any shadow caused by the interposition of the wadding, still each movement of the same affected the deflections on the scale of the galvanometer in a more marked degree than the actual clouds had done. My assistant, intercepting the light while passing the end of the box to adjust the cloud, was also noticed to affect the deflections. Thus the shadow of a man, although not visible to the naked eye, was found to interfere with the mechanical laws which govern the motion of ordinary matter. The results of the tests are given in Table 5.

TABLE 5.

Mark.	Megohms.	
	Light excluded.	Light admitted.
A	314·7	53·92
B	5·580	3·918
C	227·5	44·03
D	44·85	16·13
E	554·8	76·79
F	284·8	50·52
G	648·5	77·41
H	24·93	10·66
I	34·05	15·48
K	53·32	23·13
L	738·3	141·2
M	53·92	15·53
N	41·19	13·09
O	154·8	49·48
P	24·24	12·80
Q	·13258	·09794
R	·003157	·003157
A	314·7	59·25

During the time occupied by the test while light was excluded, the temperature imperceptibly decreased from $44\cdot5^{\circ}$ to $43\cdot8^{\circ}$. The resistance of bar A remained the same throughout the test. During the time occupied by the test in which the light was admitted, the temperature fell from $43\cdot7^{\circ}$ to $43\cdot2^{\circ}$, so that during the whole time occupied by the tests, which was ninety-five minutes, the temperature only varied $1\cdot3^{\circ}$. The apparent dull solar light had a much greater effect on the resistance of the bars than the apparent bright artificial light from coal gas. The above test was repeated at noon on a hot midsummer day, with a clear atmosphere and the rays of the sun falling direct on to the box. While light was excluded the temperature remained at 108° Fahr., and the resistance of the bar marked A remained constant throughout the test, which occupied twenty minutes. During the test with the light admitted the temperature increased from $112\cdot5^{\circ}$ to 121° , and the resistance of the bar A decreased. The intercepting of the light by the *artificial cloud* during this test had an immediate and powerful

effect on the resistance of each bar. The results of this test are given in Table 6.

TABLE 6.

Mark.	Megohms.	
	Light excluded.	Light admitted.
A	369.1	54.41
B	4.928	3.046
C	283.5	49.80
D	49.8	25.93
E	611.2	82.57
F	319.1	51.44
G	619.3	64.03
H	50.33	14.07
I	32.57	14.62
K	47.54	20.07
L	687.1	116.2
M	103.4	19.82
N	67.72	15.11
O	108.2	32.35
P	8.33	4.318
Q1675	.1229
R003374	.003308
A	369.1	51.44

The test was repeated on precisely the same conditions between eleven and twelve on a dark night, and the resistance of each bar remained constant, the removal of the lid of the box making no perceptible difference. But when the dim light from an ordinary dirty street lamp at an angle of 26° and a distance of twenty-one feet fell on the bars the resistance gradually decreased as shown in Table 7.

TABLE 7.

Mark.	Megohms.	
	Light excluded.	Light admitted.
A	537.7	505.2
B	6.965	6.810
C	387.9	357.7
D	64.29	56.75
E	999.3	892.6
F	478.9	433.7
G	1209.8	1069.1

TABLE 7—*continued.*

Mark.	Megohms.	
	Light excluded.	Light admitted.
H	42·17	38·47
I	41·79	39·97
K	63·41	63·85
L	1121·2	1044·8
M	96·78	85·13
N	69·65	60·89
O	192·3	181·7
P	23·10	23·10
Q	·18763	·16418
R	Unsteady	Unsteady
A	537·7	483·9

During the test while the light was excluded the temperature remained constant at 57° Fahr., but while the light was admitted the temperature gradually fell from 56·3° to 55°. While under the influence of the light the resistance of the bar A very gradually fell from 505·2 to 483·9 megohms. The resistance of each bar was higher in this test than it had been before, but from what cause could not be ascertained. The above test was repeated about the same time one night, when the dim light from the waning moon appeared to equal in density that given by the dirty street lamp in the previous experiment. The result was as given in Table 8.

TABLE 8.

Mark.	Megohms.	
	Light excluded.	Light admitted.
A	427·3	410·3
B	6·061	5·869
C	316·5	301·1
D	53·29	50·95
E	753·9	718·8
F	383·2	369·4
G	843·0	827·9
H	35·8	33·47
I	38·64	37·85
K	59·83	58·32

TABLE 8—*continued.*

Mark.	Megohms.	
	Light excluded.	Light admitted.
L	697·2	692·0
M	80·63	75·39
N	57·24	53·60
O	168·6	159·9
P	18·89	18·62
Q	·16383	·14007
R	·003324	·003312
A	425·4	399·7

During the test while the light was excluded the temperature gradually fell from 63° to 60° Fahr., and the resistance of bar A fell two megohms. During the test while the light was admitted the temperature fell from 59° to 57°, and the resistance of the same bar fell eleven megohms.

The following experiment was then made, which clearly shows that the resistance decreases gradually while the bar is under the influence of a dull light, and increases as gradually to its normal condition when the light is excluded. The bar marked A was the one used in this experiment. The light was admitted for seven and a half minutes, and the deflection at the end of each half minute recorded. Then the light was suddenly excluded, without in any way interfering with the test, which was continued until the resistance had returned to its normal condition, which, as shown by the figures in Table 9, was seven and a half minutes, being the same time as it was under the influence of the light.

TABLE 9.

Light admitted.		Light excluded.	
Minutes.	Deflections.	Minutes.	Deflections.
·5	272·	8·	279·
1·	273·	8·5	278·5
1·5	274·	9·	278·
2·	274·	9·5	277·5
2·5	275·	10·	277·
3·	275·5	10·5	276·
3·5	276·	11·	275·
4·	276·5	11·5	275·

TABLE 9—*continued.*

Light admitted.		Light excluded.	
Minutes.	Deflections.	Minutes.	Deflections.
4·5	277·	12·	274·
5·	277·5	12·5	274·
5·5	278·	13·	273·
6·	278·5	13·5	273·
6·5	279·	14·	272·5
7·	279·5	14·5	272·5
7·5	280	15·	272·

With a view of ascertaining to what extent the resistance of the bars would be effected by the eclipse of the moon on the 23rd August last, three of the bars, marked respectively C, E, and G, were joined in parallel circuit, and included in the circuit of fifty Minotto cells and an astatic mirror reflecting galvanometer. The box containing the bars was placed on the roof of a high building, so that the moon's rays fell direct upon it during the whole time of observation. The connections were as given in the following figure, and, with the exception of short circuiting the galvanometer to check its zero, were not altered during the test.

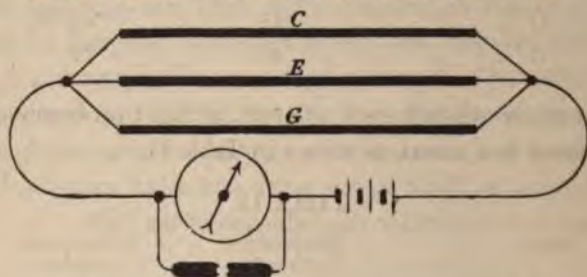

Minute readings were noted. At 8·15 p.m., when not under the influence of light, the deflection was 171 divisions, and the temperature 68° Fahr. At 8·16, after one minute's exposure to the moon's rays, the deflection had increased to 179 divisions. From 8·16 to 9·15 the deflections were alternately rising and falling, owing to the varying power of the light caused by clouds of varying density passing quickly between the moon and the bars. But at 9·15 the deflection was 190 divisions. From 9·15 to 10·17, about two minutes before totality, the deflections gradually de-

creased to 185 divisions and the temperature to 50°. From 10·17 to 11·24 the beam of light remained apparently firmly fixed on the scale at 185 divisions and the temperature had fallen to 49°. At 11·24 the deflections began to gradually increase, and continued to do so until the end of the observations, which was at 2·15 a.m. on the 24th, when the deflection was 235 divisions and the temperature 43° Fahr. If the previous tests of each of the three bars used in this experiment be referred to, it will be seen that, when exposed to solar light at temperatures of 118° and 44° Fahr. respectively, the resistance of C and E decreased with a decrease of temperature, following the law of a metal (as copper), but the resistance of G increased with a decrease of temperature, following the law of a dielectric (as gutta-percha). Table 10 gives the actual figures.

TABLE 10.

Mark.	Temperature.	Resistance in megohms.
C	118	49·8
C	44	44·03
E	118	82·57
E	44	76·79
G	118	64·03
G	44	77·

While under the influence of artificial light (ordinary coal gas) they behaved as a metal, as shown in Table 11.

TABLE 11.

Mark.	Temperature.	Resistance in megohms.
C	100	152·8
C	44	110·7
E	100	287·4
E	44	213·5
G	100	237·7
G	44	194·5

When excluded from light and the temperature obtained from solar heat, C and E behaved as a metal, but G again followed the law of a dielectric, as shown in Table 12.

TABLE 12.

Mark.	Temperature.	Resistance in megohms.
C	113	283·5
C	44	227·5
E	118	611·2
E	44	554·8
G	118	619·3
G	44	648·5

But when excluded from light and the temperature maintained by artificial heat (ordinary coal gas) they each behaved as a dielectric, as shown in Table 13.

TABLE 13.

Mark.	Temperature.	Resistance in megohms.
C	100	283·1
C	44	291·7
E	100	633·3
E	44	758·1
G	100	654·9
G	44	962·7

If the correction for temperature were applied to each bar, the results obtained during the eclipse would be more marked than they are. In the experiment during the eclipse the deflections obtained are given. The resistance corresponding to the deflection is as given in Table 14.

TABLE 14.

Deflections.	Resistance in megohms.
171	265·3
179	253·5
190	238·8
235	193·1

So that the action of reflected solar light reduced the resistance about 26 per cent. When the shadow had quite passed from view at 1·10 a.m. the deflection was 207, and went on increasing to 235. As the light at 1·10 appeared to be as bright as at 2·15, the im-

pression is confirmed that while under the influence of light time affects the results.

I think there can be no doubt that the action of light alters the electrical properties of crystalline selenium, but not permanently, for when the light is withdrawn the selenium slowly returns to its normal resistance. Solar light has a much greater effect than artificial light. The action of the light appears to be analogous to the polarisation of a dielectric (*gutta-percha*) while under the influence of an electric charge; as with *gutta-percha* so with selenium, after the removal of the cause of polarization it gradually depolarises and returns to its normal position. I have no doubt but that properly prepared selenium, while under the influence of an electric current, would be what is much needed—a very sensitive photometer, by which light alone would produce mechanical motion so as to mark upon a scale a direct reading of its intensity. By way of experiment I constructed one as follows: In a closed wooden box twenty-two and a quarter inches long, six and three-quarter inches wide, and ten and three-quarter inches deep, blackened within, were placed, in grooves cut in each side of the box, thirty ground-glass slides, six and a quarter by five inches. Unfortunately they were not so uniform in thickness as I could have wished. The distance between each slide was half an inch. On the inside of one end of the box were placed, in parallel circuit, the three selenium bars marked respectively G, E, and D, the connections of which were attached to two terminals fixed in vulcanite, one on each side of the box. Between the glass slides and the bars was a wooden slide, which, when its lower edge rested on the bottom of the box, excluded all light from the bars. In the other end of the box was an aperture to admit the rays from the light under experiment. The slides were so arranged that they could intercept the light or be lifted from its path. After the current from one hundred cells had flowed through the bars and the galvanometer in metallic circuit for one minute, and before the light was admitted, the deflection on the scale of the galvanometer was noted. A gas flame from an ordinary burner adjusted, as far as the eye could judge, to half its illuminating power, was placed opposite the aperture at the end of the box. The glass slides were

so adjusted that the rays from the gas would have to pass through nine of them before they could affect the bars. At the end of the minute the light was admitted by lifting the wooden slide in front of the bars, and after the bars had been under the influence of the light for one minute the deflection was again taken. The light was then excluded by dropping the wooden slide, and when the deflection had returned to within a few divisions of the first reading the experiment was repeated with the gas flame, as far as the eye could judge, at double its previous illuminating power. The results were as follows :

With the light excluded	.	322 divisions.
With the <i>half</i> light	. .	340 „
With the light excluded	. .	326 „
With the <i>full</i> light	. .	358 „

So that in the first experiment the power of the light was 18, and in the second 32.

The experiment was repeated, and nearly the same results obtained, as will be seen by the following figures :—

Dark	. .	329 divisions.
Half light	. .	347 „
Dark	. .	329 „
Full light	. .	360 „

Or as 18 to 31.

And here I will leave the question of the effect of light, and pass to what no doubt will more directly concern the members of this Society,—the introduction of selenium, such as would be constant in its resistance, and in every way suitable for use where even great accuracy of measurement is required. Hitherto the use of selenium has been very limited, owing to its want of uniformity in electrical resistance. Not only uniformity in different samples, but in the same sample. The time of annealing, or “crystallizing” as it is termed, and the temperature at which it is annealed, has a great effect on the degree of resistance; that is to say, if a high resistance is required, the annealing must be for a much less time, and the temperature lower, than if a low resistance is required. *But if too long a time is allowed, or the temperature carried too*

high, the resistance becomes too low, and far from reliable; and if too short a time, the resistance is very high and again not reliable. But by careful attention to both time and temperature, the amount of which will depend on the proportions of the selenium to be annealed, there is no difficulty in producing it, so that when it has settled to the normal temperature its resistance will remain constant. The results of my experiments with the samples which I have prepared myself, have more than surpassed my expectations. Properly prepared selenium follows the law of a dielectric (gutta-percha) as to temperature. I have made a series of special experiments, and from the results have compiled Table 15, in which is given the relative resistance for each degree from 100° to 40° Fahr., assuming the resistance at 100=1.

TABLE 15.

Temp.	Resistance.	Temp.	Resistance.
100	1.000	70	2.028
99	1.024	69	2.077
98	1.042	68	2.126
97	1.073	67	2.177
96	1.099	66	2.229
95	1.125	65	2.282
94	1.152	64	2.337
93	1.179	63	2.392
92	1.208	62	2.449
91	1.236	61	2.508
90	1.266	60	2.567
89	1.296	59	2.629
88	1.327	58	2.692
87	1.359	57	2.756
86	1.391	56	2.822
85	1.424	55	2.889
84	1.458	54	2.958
83	1.493	53	3.028
82	1.529	52	3.101
81	1.565	51	3.175
80	1.602	50	3.250
79	1.641	49	3.328
78	1.680	48	3.407
77	1.720	47	3.489

TABLE 15—*continued.*

Temp.	Resistance.	Temp.	Resistance.
76	1·761	46	3·572
75	1·803	45	3·675
74	1·846	44	3·744
73	1·890	43	3·834
72	1·935	42	3·925
71	1·981	41	4·019
		40	4·115

I have tested the resistance of properly prepared selenium with various battery powers, commencing with one hundred cells, and increasing the same number each test up to one thousand cells. The current was reversed in each test and remained on for ten minutes, the resistance being taken at the end of each minute. In each case it remained very constant throughout, and did not show signs of being affected in temperature by the high power as an ordinary resistance coil would have been, especially if of the same resistance. In using high resistances, especially with high power, more than ordinary care must be taken to guard against surface conduction. Having obtained the desired resistance, care must be taken that it be kept well protected from the effects of light, or it will not remain constant. Hitherto experiments in which high resistances were required have almost been out of the question, owing to the great expense of resistance coils. This will be readily understood when I mention that the cost of *one* megohm constructed of platinum silver-wire is about £80. Now, I have reason to believe that resistances equally as reliable can be supplied in selenium, from one to five hundred megohms, for about thirty shillings each. I have instructed Messrs. Elliott Brothers how to prepare them, and I believe they are willing to supply them at something like that price. The full importance of these cheap high resistances will be more fully realised when we have a good system of underground wires, for I have reason to believe, from the results of experiments I have made, that by a judicious arrangement of high resistances at various junctions in a long subterranean line the speed would be much increased. This, however, is a subject rather foreign to my present paper, but one which I may at some future time ask permission to bring before the Society.

The PRESIDENT: Mr. Willoughby Smith has brought before us a very interesting subject which promises to be of considerable importance. We have present with us this evening Professor Adams, who has communicated some interesting results to the Royal Society, he having made a vast number of experiments in conjunction with Mr. Day upon a variety of specimens of selenium differently prepared. I beg to call upon Professor Adams to commence the discussion.

Professor W. G. ADAMS: I have been much interested in Mr. Willoughby Smith's paper, and am glad to have this opportunity of making my acknowledgments to him for his kindness in placing at my disposal several pieces of selenium, which I have used in my experiments, and among them the original piece in which he first observed the change of resistance due to the action of light. I have made experiments with these and have prepared others, annealing them by different processes as described in the paper by Mr. Day and myself in the Philosophical Transactions, which has been alluded to by the President. Mr. Willoughby Smith has given us several very interesting results bearing on the relation between the resistance and the temperature of pieces of annealed selenium, and on the change in their resistance due to the action of light from different sources; some of these results, especially those with regard to the action of light, agree very well with results which Mr. Day and I have also obtained. There is one curious coincidence between our results to which I would first draw attention. Out of seventeen pieces of selenium which Mr. Willoughby Smith has annealed (I presume by the same process) there is one whose electrical resistance is increased by exposure to light, and which therefore Mr. Willoughby Smith was inclined to reject. Now we have annealed and experimented with twenty-five pieces of selenium, and in our first experiments we found that the electrical resistance of each of them was diminished on exposure to light, but after leaving them for about a year and then trying them again we found that there was one of the twenty-five whose electrical resistance was increased by exposure to light. In all the other pieces the action of light still diminished the electrical resistance. The electrical resistance of nearly all the pieces of selenium had

been very greatly altered by the action of time, which seemed to have more completely annealed them, and to have greatly diminished their resistance. In May 1877 it was found that in some pieces the electrical resistance was only one-hundredth part, and in one piece it was only one ten-thousandth part, of what it was in May 1876. This diminution of resistance by the action of time was accompanied by other changes, showing that the selenium had become more completely annealed, and that its relations to heat and light had become greatly altered. In preparing the specimens for experiment, some of them had been annealed by being raised to various temperatures between 120° C. and 200° C., kept at their highest temperatures for some hours, and then allowed to cool slowly. Others had been placed in hot sand and left for twenty-four hours until the sand had returned to the ordinary temperature of the room. In this process, when the glossy appearance of the amorphous selenium becomes changed to a dull slate colour, the conductivity of the specimen is generally found to be very good. With pieces so prepared we have found that a slight increase of temperature is accompanied by a large increase in the electrical resistance, so that a piece of selenium kept in the dark will indicate by the change in its resistance very slight changes of temperature, and may be used as a very delicate thermometer. We have also found that on increasing the strength of the battery current through the selenium there was a diminution in its resistance, and polarization, similar in its effects to electrolytic polarization, was set up in the selenium. This polarization lasts for a long time, for hours and even days, so long as the ends of the selenium are not short-circuited, but when they are short-circuited or connected with a galvanometer the usual polarization current is produced and the polarization very soon disappears. It appeared as though the selenium became charged and did not discharge itself for some days unless it was short-circuited.

The strength of this polarization-current is altered by exposing the selenium to light; in most cases it is increased, but in one piece, which is very sensitive to the action of light, the electromotive force due to polarization was opposed to, and overbalanced by, an electromotive force produced in the selenium by the action of *light*.

Whether the battery employed be 2 or 3 Leclanché cells or 20 cells, we have always found, except in the special case mentioned above, that exposure to light *assists* the battery current, that in fact the resistance appears to be diminished. This we have also always found to be the case when the light was allowed to fall only on a portion of the selenium, even when that portion was the junction of the selenium and platinum. Thus with the battery current going in one direction through the selenium, sunlight was brought to a focus first on one junction and then on the other, and in both cases the resistance appeared to be diminished; on reversing the battery current sunlight was again directed, first on one junction and then on the other, and again in both cases the resistance appeared to be diminished, so that in all cases exposure to light *assists* the passage of the battery current.

On diminishing the battery power employed, making use for instance of a thermo-electric pile in place of a stronger battery, we have found results which differ in character from those above described. In some cases when the light is brought to a focus on a junction of selenium and platinum the resistance of the selenium appears to be increased and in others to be diminished, or we may say that in some cases exposure to light opposes and in others it assists the passage of the current from the thermo-pile. In all such cases it has been found that on removing the thermo-pile, and exposing the junction to light when there was no battery current at all, the light causes a current of its own through the junction. On focussing the light on different points of a piece of selenium and also on the junction, we found that we had photo-electric currents. These currents were sometimes from platinum to selenium, sometimes from selenium to platinum, but in the same pieces always in the same direction. In those pieces which had been more completely annealed, and in which the resistance was most diminished by annealing, the current was generally from selenium to platinum at the illuminated junction, so that the conclusion at which we arrived was, that the effect of light on the selenium was such as to change the character of the selenium and make it as it were more crystalline. From the results arrived at by Dr. Matthiessen as to the thermo-electric properties of selenium, according to which selenium is placed at the bottom of the thermo-

electric scale, so that a current passes from platinum to selenium through a heated junction, we were led to the conclusion that these photo-electric currents were different in character from thermo-electric currents and in the opposite direction. But on testing the thermo-electric properties of the pieces employed in these investigations it has been found that the process of annealing raises selenium in the thermo-electric scale at the same time that it diminishes its electrical resistance, and in some cases selenium is raised above platinum, so that on heating a junction of those substances the current passes from selenium to platinum through the heated junction.

The photo-electric and thermo-electric currents were generally in the same direction. The remarkable result that in all cases exposure to light *assists* the passage of the battery current, when the battery has considerable electromotive force, is not as yet explained, and the experiments with moon-light show that the action is due to the illuminating power rather than the heating effect of the light; exposure to cold and exposure to the moonlight or to other sources of light produce the same result, viz., a diminution in the electrical resistance of the selenium.

The PRESIDENT: I would ask Professor Adams whether, looking to some of the very interesting results he has described as having obtained, he looks to selenium as providing, as Mr. Willoughby Smith has submitted, a satisfactory resistance measurement as a substitute for the resistance coil?

Mr. LATIMER CLARK: You spoke of focussing light on different bars. Did you find any variation in the same bar?

Professor W. G. ADAMS: In answer to Mr. Latimer Clark, I would say that there was great variation in the results on exposing different parts of the same bar; some parts were much more sensitive to light than others, in fact, there was no bar uniform throughout its length. Very often a photo-electric current was excited in the selenium on focussing the light on points of the selenium bar, which were so far away from its junction with the platinum, that there could be no heating of the junction. In regard to the point mentioned by the President, I may say that my experiments have not been directed to the point whether the resistance can be kept *constant* for a length of time. My observations on polarization

showed that immediately after a battery current had passed there was a state of polarization set up, which was entirely got rid of on short-circuiting the selenium, when the resistance returned to its original value. I think that selenium may certainly be employed for photometric purposes; that in fact the action of light is very uniform on selenium through which a battery current is passing. When I said that a piece of selenium was changed in resistance by the action of time, I was speaking of the effects of months and years, but in a few hours or days there is no perceptible change. If the resistance is altered by the action of light, then, in a day or two afterwards at most, generally in an hour or two, the piece of selenium will return to its previous resistance. Before it does so it may still be used as a photometer by comparing the changes of resistance produced in it by different sources of light, or by having two separate pieces of selenium electrically balanced against one another, and exposing one of them to one source of light and the other to a standard candle. Some time ago in this room, at a meeting of the Society of Civil Engineers, in a discussion on methods of photometric measurements I exhibited a selenium photometer in which two pieces of selenium were balanced against one another, forming two sides of a Wheatstone's bridge, and were so arranged that the box containing them could take the place of the photometric arrangement in Bunsen's photometer. From a number of experiments the law of the action of light was clearly made out. Comparisons made by means of Bunsen's photometer with sources of light varying from 1 to 16 candles at distances from a quarter of a metre to two metres show that the change in the electrical resistance is directly proportional to the square root of the illuminating power of the light. Exposure to light seems to cause a difference of potential in different parts of the selenium, which causes a current of its own in one definite direction where there is no battery current or a current from a thermo-electric pile, but which always *assists* the passage of a battery current through it when that current is considerable, whatever be its direction.

Mr. W. H. PREECE: I would like to ask Mr. Willoughby Smith and Professor Adams if their attention has been called to a paper by Dr. Börnstein in the last number of the "Philosophical Magazine," in which he has shown that the action of light on

selenium has not only affected the resistance but has set up in the selenium itself an electromotive force? More than that, he has shown that where dissimilar metals—platinum, silver, gold, aluminium, and one or two others—are combined together, the effect of light, on being concentrated upon the point of junction, has been not only to set up an electromotive force, but to set up an electromotive force in an opposite direction to the electromotive force set up by the application of heat, so that the tendency of the observations of Dr. Börnstein may be taken as the reverse of the opinion just now expressed by Professor Adams, that the effect of light and heat on selenium are the same. It would appear from the observations of this physicist that the effect of light was the reverse to the effect of heat, and there was one experiment of Mr. Willoughby Smith's that tended to confirm that opinion. That was, that when light was applied at a high temperature, and when light was applied at a low temperature, the effect in the latter case was much greater than the effect in the former case, showing that there was a resultant action between the photo-electric and the thermo-electric effects. We all know that in testing the resistance of bodies the effect of the introduction of any foreign electro-motive force is exactly the same as the introduction or removal of resistance; so that if careful examinations are not made we are apt to confound the introduction of electro-motive force with that of a variation in the resistance. I would therefore ask Mr. Willoughby Smith and Professor Adams if their attention has been devoted to this point? If not, I think it likely the electromotive force set up in these bodies by this action of light may tend to account for the extraordinary variations which Mr. Willoughby Smith has brought before us to-night, in what I must characterise as one of the most philosophical papers that have been brought before us for a long time.

Dr. ENGEN OBACH: Allow me to remark that about two years ago Dr. Werner Siemens, of Berlin, studied the behaviour of selenium when subjected to heat and light. His results agreed generally with those which Mr. Willoughby Smith and Professor Adams have communicated to us this evening. Dr. Siemens found that there are two distinctly different modifications of crystalline *selenium*, both of which are susceptible to light; but he did not

find the result observed by Professor Adams, that some preparations of selenium increase their resistance by being exposed to light. Dr. Siemens examined fifty or more preparations of selenium, and the result mentioned never occurred to him. I should like to make some further remarks, but having been only a short time in this country I have difficulty in expressing myself, and therefore prefer to communicate in writing some further results of Dr. Siemens' researches on this subject which may be of interest to the Society.*

Mr. WILLOUGHBY SMITH (in response to the President): I have very few remarks to make. With regard to the bar which Professor Adams found to increase in resistance while under the influence of light, I should like to ask him what was the resistance of the bar when excluded from light?

Professor ADAMS: About 5,000 or 6,000 ohms.

Mr. WILLOUGHBY SMITH: My experience tends to show that bars the resistance of which is below one megohm often follow that law, but they are changeable, and not to be relied upon. You will observe that in Table 7 bar R is marked "unsteady," that is to say, while under test its resistance was constantly varying, at one time increasing and at another decreasing. If crystallisation or annealing is overdone, the resistance becomes too low and very changeable. With our present knowledge of selenium I can readily understand how different investigators arrive at different results. With regard to the remarks of Mr. Preece I have not seen the work which he mentioned; in fact, I have read but very little referring to experiments with selenium until I received last week, through the kindness of Professor Adams, a copy of his paper, read before the Royal Society. I do not quite understand what Mr. Preece means by the electromotive force set up by the introduction of foreign substances.

Mr. PREECE: What I said was, in testing resistances, their variation is very frequently due to the presence of a foreign electromotive force, for instance, earth currents in actual telegraph wires.

Mr. WILLOUGHBY SMITH: Earth currents could in no way interfere with the tests before you, because in each case it was a metallic circuit.

* For Dr. Obach's communication see p. 498.

Mr. PREECE: What I mean is, if light sets up an electromotive force, and that acts in a different direction to thermo-electric force, it may happen that the concentration of light on a bar of selenium, by setting up an electromotive force, might lead you to imagine there was variation in the resistance, whereas the resistance remained constant.

Mr. WILLOUGHBY SMITH: I would also ask Professor Adams what metal he used as electrodes to his bars, for I am under the impression that this is important when accurate results are required.

Professor ADAMS: In all cases I used platinum junctions to selenium, and ordinary copper wire connection with platinum.

Mr. WILLOUGHBY SMITH: My experience with the selenium, which I have prepared myself, has been that for a time after annealing it gradually increases in resistance. I have never had but one sample that decreased in resistance after annealing. I thought it better in this paper to give the particulars of each test, and the actual results obtained, than to draw up a summary of the same.

The PRESIDENT: I am sure it will be your wish to return thanks to Mr. Willoughby Smith for his interesting and suggestive paper, which will no doubt be productive in the future of valuable practical results. I will now call upon Mr. Preece to give us his paper "On the Measurement of Currents."

ON THE MEASUREMENT OF CURRENTS.

By W. H. PREECE, Vice-President, Memb. Inst. C.E., &c., &c.

A *unit* is some fixed or selected magnitude to which all concrete quantities of the same kind can be compared or by which they can be measured. The numerical value of any quantity is its ratio to this unit. The common unit of length is the *foot*, of mass the *pound*, and of time the *second*, but the generally accepted scientific unit of length is the *centimetre*, of mass the *gramme*, and of time

the *second*. All true physical units are derived from these fundamental units and are called *absolute*.

The proper selection of an absolute system enables scientific men of all nations to bring together all kinds of physical quantities to one common scale of comparison.

It is impossible to over-estimate the value to Telegraph Engineers of the absolute system of electrical measurements. It has brought us all within one fold. However diverse may be the instruments we use, we can comprehend electrical conditions everywhere if properly stated.

The Committee of the British Association, appointed in 1861, which determined the unit of *Resistance* and called it an *ohm*, also determined similar standards for the relative measurement of other electrical quantities, viz., *Electrical Quantity*, *Capacity*, *Potential* or *Electromotive Force*,* and *Current Strength*. No name has been given to the unit of electrical quantity, but the unit of capacity, which is based upon it, has been called a *Farad*. The farad is in fact that condenser which contains unit quantity when raised to unit potential. The name of *Volt* was given to the unit of electromotive force, and the name of *Weber* was given to the unit of current. Each of these units has been brought into general use with the exception of the last, and of them all, probably the last is the most important, and is likely to be used as much as any other. In America, where, as a rule, the scientific points of telegraphy have been rather neglected, the use of the weber has been pretty general, and there it is the practice to speak of the strength of currents, either leaving a station or entering a station, as equivalent to so many webers. On several occasions I have been asked, "What is the strength of currents that leave your stations?" and I have been ashamed to acknowledge that I was unable to tell without calculation. Mr. Warren de la Rue suggested that we should always measure the strength of our currents by a voltameter; but a tangent galvanometer, a sine galvanometer, or, indeed, any other practical form of galvanometer, is equally serviceable under the absolute system of measurement.

* Electromotive force is difference of potential, and, when earth is used for one point, potential and electromotive force are synonymous.

Now, the unit of current strength, or the weber, is that current which is produced by one volt, acting through one ohm: it is, in fact, the value of C in the equation

$$C = \frac{E}{R},$$

when all three magnitudes are expressed in the absolute system. Whenever we know the value of E in volts and the value of R in ohms, we have got the value of C in webers. It very fortunately happens that the electromotive force of an ordinary Daniell cell is almost exactly the volt—really, for a pure Daniell's cell, it is 1.1 volt—so that where we know the number of cells and the resistance of the circuit we have approximately the number of webers flowing. Thus, for example, if the resistance of a line with its instruments be 500 ohms, and we employ a small 10-cell Daniell (whose resistance would be about 200 ohms) to work it, then the current flowing would be

$$C = \frac{10}{500 + 200} = .014 \text{ webers.}$$

It, however, happens that inasmuch as the number expressing the resistance of our circuits in ohms is always very much greater than the number expressing the electromotive force in volts, the currents used for telegraphic purposes are invariably less than a weber. Hence it becomes advisable to use a sub-multiple of the weber in the same way that we have a sub-multiple of the farad, viz., the "micro-farad." The same reasons, but in the opposite direction, have introduced a multiple of the ohm, the "meg-ohm," as a measure of the insulation of gutta-percha and other coated wires. The sub-multiple that I suggest is the $\frac{1}{1000}$ th part of a weber, or a *milli-weber*. Thus the above current would have been 14 milli-webers.

In indicating these different magnitudes it has been customary to follow the plan adopted in indicating degrees, minutes, and seconds, by giving to the ohm the Greek letter ω , and to the megohm the capital Greek letter Ω . But to the farad—although I suggested some years ago the Greek letter ϕ —the same plan has not

been adopted. However, I propose now to adopt it, and to indicate the farad by the capital letter Φ , and the microfarad by the small letter ϕ . Similarly with the weber, to which I propose to apply the capital Greek letter Γ , and to the milli-weber the small Greek letter γ ; a symbol which is already extensively used in mathematical papers to indicate the strength of currents.

Now, to obtain the value of a current upon a circuit in milli-webers it is only necessary to take a reading on any galvanometer whose resistance is known, and then to reproduce that reading upon a known artificial line. Knowing the electromotive force and the resistance of the battery, the resistance of the line, and the resistance of the galvanometer, we obtain at once the current strength in webers. To obtain milli-webers we have simply to multiply this result by 1,000. Thus, for example, if, with an ordinary galvanometer of 100^{ohms} resistance and a 10-cell Daniell of 200^{ohms} resistance, employed for working a line, we obtained a certain deflection on the line, and, to reproduce this deflection, we found it necessary to replace the line by a resistance of 500^{ohms}, then the strength of the current working the line would be

$$\frac{10}{100 + 200 + 500} = 12.5\gamma$$

With a tangent or sine galvanometer the operation is simpler, for we have only to make one observation, either upon a constant or upon a known line, to be able to obtain the "reduction factor," so as to be able to produce the equivalent value for each degree of deflection.

The use of this standard will enable us to form a figure of merit which will represent the sensitiveness of any galvanometer or electro-magnet, for we simply have to find the resistance through which a single cell, or any given number of cells, will actuate a relay, or move a galvanometer needle a given number of degrees to get a reading which will give us a standard expressing the sensitiveness of the instrument under trial in milli-webers. Thus, for example, if we find that a one-cell Daniell would actuate a relay whose resistance

is 500^w through a resistance of 8,000^w, then the figure of merit of the relay would be:—

$$\frac{1}{8000 + 500} = \cdot 1187$$

The following indicates the figure of merit of several relays:—

	Resistance of Coils.	Marks good through.	Figure of Merit.
No. 1	414 ^w	22,000 ^w	·047
No. 2	608 ^w	18,000 ^w	·057
No. 3	303 ^w	10,000 ^w	·097
No. 4	696 ^w	22,000 ^w	·047

This method at once enables us to conceive a very clear idea of the condition of a line during various changes of weather. Thus, while on a fine day both the sending and receiving currents at each end of the line were equal and about 6·57 on a wet day the sending current became 207 and the receiving currents only 37. If the strength of current in milli-webers were recorded at several stations along a line it would be possible to plot out in a curve the condition of insulation along its whole length.

The PRESIDENT: We are much indebted to Mr. Preece for this very suggestive paper. There can be no question as to the thought he has given to the subject, and I am sure the suggestions he makes will be received with satisfaction, although they may give rise to discussion on the part of those who are anxious to adopt precision and uniformity of measurement. It is too late to invite discussion, but we shall be happy to hear any remarks upon the points raised by Mr. Preece.

Mr. LATIMER CLARK: Mr. Preece has again brought before us an illustration of the practical character of the Americans in connection with telegraphy. I have no doubt he has greatly profited by his visit to that country and by the study of their system of telegraphy. I should like to ask in this case how they use the system of measuring the strength of the received current by the

weber or milli-weber? For example, a strong battery on a line of great resistance will give the same strength of current as a weak battery with a line of low resistance. Have they any standard battery power that they use? I observe that Mr. Preece has departed from the custom now in use of division by millions, and has divided the weber into thousandths. As a matter of practical convenience I do not deny that it is an advantage, but I do not think the mere philosophical part of the electrical world will at once adopt the new sub-division. It is, however, well suited for use in practical telegraphy.

Mr. PREECE: The chief beauty of the system of measurement in terms of the milli-weber is that it places you perfectly independent of the sources of your currents and of the character of your line. You simply have to measure the current that passes through your instrument, and whether it comes from a given line or not, whether from a strong battery or a weak, whether from a thermo-battery, a galvanic battery, or photo-electric or any other motor, is a matter of indifference. All you have to measure is your current. The current is that which is doing your work, so that the chief merit of the system I have suggested is that it makes you free from any other conditions except the mere strength of current that comes to you and does your work. In America they do use to a certain extent uniform batteries, they have only two forms—one for line purposes and the other for local purposes—and this uniformity of apparatus characterises their whole system. Though the battery used is the gravity battery, yet this system of measurement is independent of all battery-power. In this system I do not think I am strictly scientifically wrong, because the metre and millimetre are precisely the same relatively as I have shown here the weber and milli-weber to be. I do not propose to introduce the micro-weber, because that will give values a great deal too small, whilst, on the other hand, the milli-weber gives more useful quantities even than the ohm. When we speak of milli-webers as working instruments, we find we do not require more than the ordinary digits to represent the practical strength of the current. The average working current is about five milli-webers. When we

find the strength of the current falls below one milli-weber, it is very weak and we are likely to suffer. On the other hand, when it is ten milli-webers or upwards it becomes too great, so that it conveniently happens that between one and ten we have the practical limit of the strength of currents in milli-webers. I therefore advocate the milli-weber, because it gives us the most useful and practical numerical quantity we can use.*

Adjourned.

During the recess the following gentlemen have been advanced from the class of Associates to that of Members:—

Mr. J. R. Brittle.	Mr. H. H. Tubb.
„ Paul Estler.	„ John R. Edwards.
„ H. C. Fischer.	Lieut. C. T. Beresford, R.E.
„ J. C. Fleming.	Mr. C. B. Wood.
„ Ernst Guenzel.	„ John Lavender.
„ C. Hoeltzer.	„ A. W. Heaviside.
„ F. Jacob.	Major A. G. Durnford, R.E.
„ G. R. Kaiser.	Mr. Louis Stearn.
„ F. H. L. R. Möll.	„ F. Isherwood.
„ Otto Schramm.	„ John Jenkin.
„ T. Blissett.	„ R. G. B. Davids.
„ G. G. Charles.	„ Alfd. Eggington.
„ D. B. Cromartie.	„ F. Higgins.
„ J. Douglas.	„ J. J. Fahie.
„ G. A. Goslin.	„ James Gavey.
„ G. Richardson.	„ Jno. Bailey.
„ H. E. Thompson.	„ Edward Butler Harley.
„ M. L. E. Thornton.	Capt. C. Fraser.

* If observers all over the world would express in milli-webers the strength of earth currents, giving their direction and the resistance of the circuits, we should have all the conditions required to know their electromotive force—a point much wanting in observations hitherto taken.—W. H. PREECE.

Mr. J. Morris.

Capt. John Ramsay, R.E.

Mr. Arthur Schindler.

Mr. John Neale.

,, Louis Crossley.

The following Students have been advanced to the class of Associates :—

Mr. S. F. Hooper.

,, A. Hayes.

,, E. Palliser.

,, T. Gatehouse.

Mr. J. D. Warren.

,, W. H. Cochrane.

,, H. F. McKain.

,, C. H. Phillips.

The Sixty-first Ordinary, and Sixth Annual General Meeting, was held on Wednesday, the 12th December, 1877; Professor ABEL, C.B., F.R.S., President, in the Chair.

The President announced that the ballot for President and Council for the ensuing year would be, and remain, open until half-past eight o'clock. Messrs. Gavey and Gerhardi were appointed Scrutineers of the same.

The Acting-Secretary then read the Annual Report of the Council to the Members, as follows:—

ANNUAL REPORT FOR THE YEAR 1877.

GENTLEMEN,

Agreeable to custom, and to the statutes of the Society, your Council have much pleasure in meeting you this evening to render to you an account of the operations of the Society during the year now terminating, and to inform you of its present condition.

It is with feelings of gratification they direct your attention back to that period whence the Society took its start. Your first Council was elected on the 30th of June, 1871, at which time the total number of Members was less than 60. During the comparatively short period which has elapsed between that date and the present, this number has increased to very nearly 900. The first meeting of the Society took place beneath the fostering roof of the Institution of Civil Engineers, on the 28th of February, 1872. From that date to the present the Society has received from the several Presidents, the Council, and the Members of the Institution of Civil Engineers, the same kindly help associated with a generous interest in the welfare and advancement of the Society. To the Institution of Civil Engineers the Society owes much, and to its President and Council are at all times due our best thanks.

In recognition of those early services rendered to telegraphy by Sir William Fothergill Cook, your Council have unanimously elected him an Honorary Member of the Society, a proceeding which it is felt you will cordially indorse.

The Council have pleasure in congratulating the Members on the continued progress of the Society. During the past year its numbers have been increased by—including those which stand for election this evening—

38 Foreign Members
23 Members
137 Associates
6 Students

Forming a total of 204

It is clear from these figures, as well as those accompanying previous reports, that the objects of the Society, its utility, and its work, are becoming year by year more fully understood and appreciated. Were it necessary to emphasise this fact nothing stronger could be advanced than the number of new candidates announced on the occasion of the last meeting, and again this evening, 79 of whom stand for ballot ere we separate to-night. Amongst these you will find the names of Professor Alexander Graham Bell, to whom the world is indebted for the discovery of a means by which articulate speech can be transmitted to distant points, as well as that of M. Paul Jablochhoff, whose researches in connection with the electric light are well known. Assuming that those gentlemen whose names are submitted for election this evening pass the required ordeal to establish them as members of the Society, your numbers will then stand as follows: viz.—

Honorary Members	6
Foreign Members	164
Members	319
Associates	456
Students	13
	<hr/>
Total	958
	<hr/>

During the year 8 Students have been transferred to the class of Associates, whilst 31 Associates have obtained the higher grade of Membership.

In this there is much and just cause for congratulation, but in reviewing our present with our previous years' constitution we have brought home to us also, the fact that there has been removed from amongst us, one whose name is indissolubly linked with the advancement of telegraphy in the Indian Empire. None knew better than your Council that in the event which deprived the Indian Telegraph Department of the valued services of the late Major-General D. G. Robinson, the Society was equally deprived of one of its warmest supporters as well as one of its chief ornaments. Called away in the midst of his labours, he carries with him the respect and esteem which his love of the service and his advancement of the science, so justly merit from all by whom he was known, either as a friend or an officer. Here it is impossible to more than mention the loss the Society, in common with the entire telegraph service, has sustained. In the Journal which will be due to you shortly after Christmas will be published a full obituary, in which every effort will be made to do justice to the memory of a man who has done so much for telegraphy and whose loss we all so deeply deplore.

During the year no fresh additions have been made to the list of local Honorary Secretaries, but the gentlemen who have so kindly undertaken those duties, and whom the Council desire to thank for the manner in which they have protected and advanced the interests of the Society, have been requested to undertake, in addition thereto, the important and onerous duty of local Honorary Treasurer. The object which the Council have had in thus seeking the further aid and kindly co-operation of these gentlemen, has been to afford Members resident within their secretariat, a means of paying their subscriptions with regularity; and the Council take this opportunity of commending to such Members the convenience of adopting this course. It is needless to remark that the regular remittance of subscriptions, as they fall due, will save time and trouble to those who have so readily responded to the request of the Council, and it is but due to those gentlemen that Members

should bear this fact in mind, inasmuch as the duty which they have undertaken is entirely honorary, and accorded purely from a desire to advance the interests and welfare of the Society, in the benefits of which one and all alike participate.

With regard to these appointments, however, it is believed there is a large field of usefulness for the Society in America. At the present moment Mr. G. G. Ward is the Society's sole representative there. Mr. John Dakers, the manager of the Montreal Telegraph Company, who has been a Foreign Member of the Society for some years, has been kind enough to offer, at the request of the President and Council, to undertake the duties of local Honorary Secretary and Treasurer for Canada. Another name before you is that of Mr. Stephen D. Field, of San Francisco, nephew of Mr. Cyrus Field, who has been asked to represent your interests in the Southern and Western States, whilst Mr. C. H. Summers, of the Western Union Telegraph Company, Chicago, at present a Foreign Member of the Society, has been asked to carry out similar duties in the Central States.

It is with unqualified pleasure your Council record the fact that the Proceedings of the Society are now printed up to date, and in the hands of Members. Your Council have now a hope that the publication of the Proceedings will be effected regularly. As the large amount of arrears in this respect has now been cleared off, this may with confidence be looked forward to, and contributors may thus rely upon such communications as they may place in the hands of the Council appearing in due course.

The following papers, read during the year, together with that appointed for this evening, testify to the character of the work dealt with by the Society during that period :—

The President's Inaugural Address.

“On Shunts, and their application to Electro-metric and Telegraphic purposes,” by W. H. Preece, M.I.C.E. Vice-President.

“On Fire Telegraphs,” by R. von Fischer Treuenfeld, F.R.G.S.

“On the Automatic Step-by-Step Type-Printing Telegraph

Apparatus used by the Exchange Telegraph Company,"
by F. Higgins.

Description of the "Autokinetic System" in application to Fire Alarms.

"On Underground Telegraphs," by Willoughby Smith.

"On the Underground Telegraphs in France," by John Aylmer, Civil Engineer, Hon. Secretary for France.

"On Quadruplex Telegraphy," by G. B. Prescott.

Description of M. Ailhaud's System for Duplex Working, in operation on the Marseilles-Algiers Cable.

"On Batteries," by Martin F. Roberts, F.C.S.

"On Double Current Translation," by Gustav Risch.

Description of a New Form of Electric Light, by the Acting-Secretary.

"Researches in Electric Telephony," by Professor Alexander Graham Bell.

"Selenium, its Electrical Qualities and the effect of Light thereon," by Willoughby Smith.

"The Measurement of Currents," by W. H. Preece, Vice-President, M.I.C.E.

"Earth Currents," by Alexander J. S. Adams.

"The Sonorous properties of Electro-Magnets," by Alexander J. S. Adams.

But, as is well-known, the value of the Journal does not rest solely with the publication of the Society's Proceedings; for to these are added all communications of an original character of value to the science which from time to time come before the Council. These include—

"Note on Electro-Magnets employed in Telegraphy," by Emile Lacoine.

"On Electro-Magnets for use in Telegraphy," by Emile Lacoine.

"Abstracts and Information regarding Soundings taken with Sir William Thomson's Apparatus on the West Coast of South America," by H. Benest.

"Description of combined Key and Switch," by Andrew Jamieson.

“On Unifilar Suspension,” by W. E. Ayrton and John Perry.

“On the Principles to be observed in the Erection of Wires over Long Spans,” with Tables, by R. S. Brough.

“Improved Make and Break Arrangement for Sir William Thomson’s Recorder Mill,” by James Graves.

“On the General Theory of Duplex Telegraphy,” by Louis Schwendler.

“On a Case of Lightning; with an Evaluation of the Potential and quantity of the Discharge in Absolute Measure,” by R. S. Brough.

Whilst to these are added various Abstracts and Extracts, the whole forming a volume of from five to six hundred pages of original matter, the value of which there is reason to believe is in every way duly appreciated.

In dealing with this branch of their duties your Council have ever had before them, not merely the extension of the numerical strength of the Society, but also and more especially that of its influence in the dissemination of information of utility and value to the electrical engineer, the student, and to the science generally. It has been their object to further establish that large and international basis upon which it was sought at the outset to found and to build the Society; to make of it one common centre, to which should come all that should contain matter of interest for those attached to the profession, or for those who, from a love of the science itself, although not allied with it professionally, yet find interest in pursuing the development of a subject, the extent and value of which none of us can yet foresee. To be the common recipient of all such information; to sift it, mould it into form, and again to cast it forth for the improvement of others and the advancement of the science, is an object the attainment of which cannot fail to reflect honour upon any Society. It is in this direction your Council have laboured, and in it they have been in no small measure aided by those who have furnished subjects for discussion and consideration at your hands; whilst, by means of the Members at home and abroad, and in various other ways, they have been

able to circulate the work accomplished, it may fairly be said, throughout the known world.

And here your Council would take advantage of the opportunity to impress upon every Member of the Society the benefit to be derived from a free and generous interchange of ideas and researches of every description. The Society is fortunate in having enrolled amongst its Members almost every name which has advanced to fame in electrical science—men whose capacity to deal with, and to express opinion upon, every matter appertaining to the science which may be brought before them cannot be doubted. From every quarter of the globe there is something to be learnt, something which cannot fail to interest those whose occupations tie them to other parts, whilst the collection and comparison of general statistics may even prove of much general service. For instance, it cannot be doubted that a great practical value attaches to a general system of observations of atmospheric electricity; that in fact all climatic and meteorological changes are preceded by disturbances in terrestrial magnetism. The necessity of obtaining observations thereon, of reducing them, if possible, to a common standard, and obtaining therefrom a basis on which to form future calculations, is a subject of high interest and value, and one which on these grounds commends itself to the consideration of every Member of the Society.

And here again attention may well be directed to the interest involved in the interchange of information on the systems of construction and management of lines of telegraph where unusual difficulties have to be met and overcome. Your Council feel that such information cannot but prove of interest and value to every practical Telegraph Engineer, many of whom, we must remember, are so situated, that apart from the means afforded by the Society's Journal they have little opportunity of gaining information of what is being done elsewhere.

Communications on improvements effected in working apparatus, in circuit arrangements, and in the manipulation of various important and advanced electrical arrangements, are also subjects of value which will always command the attention of your Council.

In thus distinguishing these subjects it must not, however, be understood that contributions of another character are less esteemed, or that less value is placed upon those other papers and communications with which it has been our privilege to deal during our term of office. The position these papers and communications hold in the Society's Journal vouch for their character and importance, and to the authors of them, one and all alike, are due the thanks of the Society.

With the object of protecting the interests of Members it has been deemed desirable to raise the price of the Society's Journal to 7s. 6d. per ordinary number, and you will have observed that this regulation has already been applied to the numbers recently issued. Hitherto it was possible for those outside the Society to obtain the Journals containing the year's proceedings for a less sum than that which represents the annual subscription of a non-resident Member or Associate, and thus those stationed out of England were absolutely placed, with regard to the possession of the Journal, at a disadvantage. The step taken by your Council will remedy this. The price at which the Journal may be obtained by Members remains the same.

Before leaving the subject of publication, it is desirable that the attention of Members should be drawn to the necessity of keeping the Secretary informed of any changes which may take place in their addresses. There is reason to believe that several of the communications issued by the Society, together with a number of Journals, have, from neglect of this, failed to reach those for whom they were intended. It is believed, too, that in many instances Members' titles and their connections with other societies are omitted. The Secretary will be glad of any corrections which Members may find desirable.

It is with much pleasure the Council finds itself in a position to report the completion of the Ronalds Catalogue, which is now in a state ready to be placed in the printers' hands. The work has been one of considerable magnitude, and has required great care and labour. The question of printing it is one which will involve the outlay of a large sum. The Catalogue itself can scarcely be considered a part of the Transactions of the Society, but it is probable

that to most of the Members a copy of it will form not only a valuable book of reference, but that it will be to them a *souvenir* of him by whose early labours, in that field of science which he made so especially his own, the Society has so largely benefited. The Catalogue contains between 12,000 and 13,000 entries, and will probably comprise about 600 or 700 pages, and, as the state of the funds of the Society will not at the present time permit of its issue to the members gratis, it has been thought desirable, rather than delay its publication, to issue the Catalogue to those only who may subscribe for it, at the nominal charge of 6s., a sum considerably under its cost to the Society. The charge to those not connected with the Society will not be less than 15s., and the number of copies issued to Members of the Society will be limited. Its publication will be proceeded with at the earliest moment possible.

As soon as this Catalogue has been issued it will follow as a natural consequence that many will seek reference to the valuable works now in the possession of the Society. Many of these are scarcely in a condition for such a purpose, being unbound or badly bound. To put the entire library into a fit form for reference the volumes must be securely bound, lettered, and systematically arranged on the shelves. The cost of this will be heavy. It is proposed that it shall be met by a general subscription, which will accordingly be shortly set on foot.

Your Council here desire to record the liberal spirit in which the Commissioners of the Patent Office have met the request of your President to present to the Society copies of all specifications relating to electricity. A large number of these are now in the possession of the Society, and other consignments are being prepared. When bound they will form a series of some 60 to 70 volumes, the value of which you will readily realise, inasmuch as it will place in the hands of the Society a complete set of all patents connected with electricity and magnetism up to the present date.

Your Council have pleasure in announcing that papers for the ensuing session have already been promised on the following subjects :—

1. American Telegraphy.

2. Insulators.
3. On the Law of International Telegraph Traffic.
4. Colonial Telegraphs.
5. The Switch System of Intercommunication in Railway Trains.
6. Cable Grappling and Lifting.
7. Locomotive Torpedoes.
8. On the unit of the Birmingham Wire Gauge.
9. Sound in relation to the Telephone.

Efforts will be made to bring the present portion of the session to a close by a paper, and general discussion, on the Telephone, so that, whatever progress may have, in the meanwhile, been made with regard to it, such may be recorded in the Proceedings of the Society.

There remains but one more point on which to dwell, viz., the financial position of the Society. On the occasion of the last annual Meeting it was found necessary to direct attention in a very pointed manner towards the large amount of arrears of subscriptions standing on the Society's books. There is still a larger amount outstanding than there should be, and your Council take this opportunity of again urging those in arrear to meet the demands which have been made upon them without delay. With the object of stimulating greater punctuality in this respect, the Council have decided that Rule 27, which forbids the issue of the Society's publications to those in arrear, shall be strictly enforced.

In conclusion, Gentlemen, there is every reason to believe that the progress attained by the Society during the past year will characterise its course throughout the coming year; but it must not be forgotten that according to our aim so must be our effort. Your Council will heartily aid your efforts, but without your aid your Council can do little.

STATEMENT OF RECEIPTS AND
RECEIPTS.

						£	s.	d.	£	s.	d.
By Balance 31st Decr. 1876				129	6	7
„ Subscriptions	1872	2	2	0			
„ „	1873	7	4	0			
„ „	1874	16	10	0			
„ „	1875	51	17	0			
„ „	1876	147	7	0			
„ „	1877	828	8	5			
„ „	1878	26	13	0			
									1,080	1	5
„ Composition of Life Subscriptions				20	0	0
„ Publishing Fund				13	1	0
„ Sale of Journals				33	10	8
Total									£1,275 19 8		

STATEMENT OF THE

On 31st

INCOME.

										£	s.	d.
By Donations	200	0	0
„ Compositions	211	15	0
Total										£411 15 0		

ESTIMATE OF ASSETS

On the 31st

ASSETS.

										£	s.	d.
To Unpaid Subscriptions	506	16	0
„ Furniture	210	0	0
„ Objects presented to the Society	215	0	0
„ Journals in hand	418	0	0
Cash in hand										102 17 10		

£1,452 13 10

EXPENDITURE FOR THE YEAR 1877.

EXPENDITURE.

	£	s.	d.
To Salaries—Clerical Assistance and Draughtsman	147	0	0
„ Shorthand Reporter	17	6	6
„ Attendance and Refreshments at Meetings	16	5	8
„ Printing and Stationery	615	17	1
„ Lithographing	54	11	6
„ Ronalds Library—Preparing Catalogue and Insurance	43	9	0
„ Rent, Taxes, and Fuel	175	17	0
„ Petty Expenses, including Shipping Journals, Postage and Receipt Stamps, &c.	102	15	1
	<hr/>		
	£1,173	1	10
Balance Cr.	102	17	10
	<hr/>		
Total	£1,275	19	8

We have compared the above Account with the Vouchers and Cash Books, and find it to be correct, leaving in the hands of the Bankers one hundred and two pounds, seventeen shillings, and ten pence.

J. WAGSTAFF BLUNDELL, }
FRED. CHAS. DANVERS, } *Auditors.*

CAPITAL ACCOUNT

December, 1877.

EXPENDITURE.

	£	s.	d.
To Furniture and Fittings	376	4	6
Balance Cr.	35	10	6
	<hr/>		
Total	£411	15	0

AND LIABILITIES

December, 1877.

LIABILITIES.

	£	s.	d.
By Salaries	42	10	0
„ Petty expenses	26	3	7
„ Printing, Stationery, and Lithographing	679	3	7
„ Short-hand reporter	5	5	0
„ Attendance and Refreshment	6	4	5
„ Ronalds Library	10	8	7
„ Rent, Taxes, Fuel, &c.	91	19	0
„ Subscriptions paid in advance... ..	26	13	0
	<hr/>		
	888	7	2
Balance Cr.	564	6	8
	<hr/>		
	£1,452	13	10

It was proposed by Lieutenant-Colonel Crossman, R.E., seconded by Mr. Hooper, and carried unanimously, "That the Report be adopted, printed, and published."

The following papers were then read:—

EARTH-CURRENTS ON LAND LINES.

By Mr. A. J. S. ADAMS, Postal Telegraphs.

1. If an electrical conductor, such as a metal wire, be extended from one point of the earth's surface to another, but insulated from it except at its extremities, a variable electric current will become apparent directly a sufficiently sensitive galvanometer is inserted upon that insulated conductor. To this mysterious force has been applied the term "earth-current."

Telegraph lines generally are affected by this natural electric power, and upon occasions of extraordinary manifestation their working capacity is more or less reduced.

Unless specially sought for, earth-currents are not always readily apparent, although careful application should at any time discover their presence, because whilst ordinary and artificially caused changes of electric energy occur quickly, passing by a bound from one appreciable quantity to another, the earth-current variations are slow and gradual, tardily rising and falling between temporary periods of rest.

Our actual knowledge regarding this phenomenon is meagre, perhaps on account of the many impediments offered to *exact* observation. The difficulties experienced with land-line observation are chiefly the leakage of working power from wire to wire during seasons of wet, and the inductive action exerted between one wire and another in dry weather, together with the contradictory earth-currents that frequently present themselves upon the same wire, or upon two or more wires that terminate in the same locality; for instance, where a negative current is received when the distant end of the conductor is in connection with the earth, whilst a positive current becomes apparent directly the same distant end is disconnected.

Occasionally these influences have been so considerable that the *whole night's* labour has proved futile. To an extent, however,

these disturbances have been traced and eliminated, or rendered less apparent, by changes of wire and by the apparatus adopted for observation.

The apparatus used consisted of a sensitive reflecting galvanometer, so arranged that a four-foot ray could traverse ten feet of screen, that is to say, five feet right or left of zero, and the scale divisions were in inches and tenths. One end of the galvanometer coil was connected to the London earth, namely, the Postal Telegraph system of pneumatic tubes, and the other end was joined through a set of resistances to the line. These resistances could be varied at will, and were the means employed to reduce the effect of line disturbance, the value of the observed current being corrected by the value of the resistance used.

The wires experimented upon were separately joined to a row of terminal screws that extended within easy distance of the reflector screen, and it was found that with a little dexterity reliable readings could be obtained upon twelve or fifteen wires in succession, without derangement to the result from loss of time.

2. The appearance of an earth-current is generally that of a weak force, slightly but continually varying in magnitude, yet often, for hours, constant in directive influence. Occasionally, however, the current is exceptionally unsteady, and the observed variations are sharp and jerky; whilst, more infrequent still, currents of extraordinary strength sweep to and fro.

Earth-currents of considerable strength have, during the past three years, been rare.

3. As already stated, the earth-current is an ever-present force. Where no current is apparent upon a wire—with the exception of street and other very short lines—the want is due, not to the absence of tension, but to an insufficiently sensitive means of observation, or to a temporary balance of potential during a change of directive energy. Night and day, throughout all weathers and seasons, this subtle force exerts its influence; and if there be an ascertainable difference of normal strength it is that the clearer the atmosphere and its comparative freedom from cloud the stronger is the earth-current manifestation.

4. Earth-currents are *materially* and not *atmospherically* conducted.

If a *perfectly insulated* wire, upon which an earth-current exhibits itself when the distant end is in connection with the earth, be disconnected at any part, the current at once disappears. So too, if, when the extremities of the wire are in connection with the earth, resistance be introduced, it will be observed that as that resistance is increased the earth-current will diminish, and *vice versa*.

But when an *ordinary* line wire is disconnected at the distant end it frequently occurs that a current coincident with, or opposed in sign to, that which had been observed when the wire was in connection with the earth, presents itself. If in this case the wire be tested for leakage, it will, as a rule, be found that the loss of insulation approximates in value to this minor current; and it is noticeable that, whereas earth-current variations are in themselves steady when received from the distant end, those variations which occur when the distant end is disconnected are often influenced by slight quick vibrations, apparently due to disturbing forces at the points of leakage.

It sometimes transpires that earth-currents are observed to differ both in sign and magnitude upon two or more wires that terminate in the same locality, and the obvious and ascertained explanation of these contradictory forces is based upon the fact that the polarity which obtains at each particular point of leakage asserts itself upon the wire, so that the current received from the distant end is + or - the balance of these intermediate forces; and, moreover, that if the value of the intermediate elements be added to, or subtracted from, the currents received from the distant end, these latter will more nearly agree.

The following illustration of one of a number of similar experiments will demonstrate the *material* conduction of earth currents.

Wires are here represented as extending—one *direct* from London to Bristol, another from London to Leeds. Two other wires extend *indirectly* to these stations; the one from London to Bristol *viâ* Leeds, the other to Leeds *viâ* Bristol. If earth-currents were other than materially conducted, or were the product of local induction, or atmospheric influence, the currents received at London upon these wires would be determined by the electrical *state* of the localities over which the wires respectively extended; *but an examination* of the forces received in the experiment shows

that they each accord with the electrical state of the locality to which

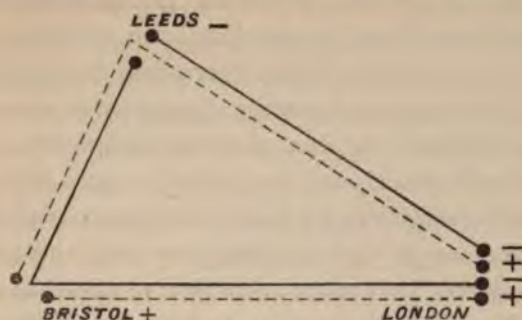

Fig. 3.

they extend, and at which they were in connection with the earth.

5. Earth-current variations, both in direction and magnitude, occurring between any number of points in the United Kingdom, coincide for the same moment of time. For instance, at intervals of ten minutes, observations to determine dynamic variations, were simultaneously made upon wires extending from London to Edinburgh, Newcastle, Sheffield, Leeds, and Northampton respectively; and the curves of the observations so obtained are given upon Plate I., clearly demonstrating that for each moment of time the relative values of force coincide. Thus at 6.30 p.m. the earth-current possessed a negative sign at each point, whilst ten minutes later the polarity of all had become strongly positive. At 7 p.m. the whole had again passed to negative; and so to the end of the series the variations occurring at one point are concurrent with those of the remainder.

Other observations exhibit the same feature as deduced from readings made in a similar manner to Chester, Dublin, Southampton, and Jersey, and moreover elicit the fact that spaces of water, such as the English and Irish channels, do not materially retard the concurrency of earth-current variations, whilst upon wires extending from London to Liverpool, Southampton, Deal, Colchester, Bristol and Margate, such examples could be multiplied *ad infinitum*.

6. The chief aim of my labours has been to obtain conclusive evidence as to a possible line of maximum force, and its direction. Considerable difficulty was experienced, however, owing to the conflicting forces already alluded to, and to the want of a sufficient

number of idle wires for the purposes of observation. From midnight until 6 a.m. has been usually the quietest time, so that from ten to fifteen wires have during those hours often been available. Sometimes the curves of a night's observations, upon being worked out, offered nothing tangible; owing apparently to a swamping of the true earth-current by local electrical disturbances; but upon other occasions unanticipated and reliable results were obtained. Each series of observations for directive and maximum force consisted of simultaneous readings upon the several wires, at intervals of fifteen minutes throughout the night; the total number of nights together with three days upon which observations were thus taken being seventy-four. From the figures so obtained curves of comparative force were drawn, and from these curves the line of mean maximum force, and its direction, was deduced. Plates II. and III. furnish examples. Note the curves for the night of June 27-28, 1876, Plate IV. Here the perpendicular parallels denote the points to which the wires used for observation extended, and are divided by a normal line, or line of no current. The forces given above the normal line are as of a copper current from London, those below the line represent currents as of a copper to London. Taking the curve of simultaneous observations made to the several points at 2 a.m. we find that the line of strongest current extended between Portsmouth and a point somewhere between Lynn and Hull, and that its direction was from the former to the latter point, whilst all the curves so nearly agree, that the mean of the whole gives a line of maximum force between almost the same points.

To obviate the necessity of supplying the curves of each series of observations, the mean lines of force for a number of nights during 1873-'74-'75 and '76 are defined by the finely drawn lines, whilst the mean lines of maximum and directive force for all the observations made, are represented by the thick lines shown upon the chart, and indicate a normal maximum line between nearly north-east and south-west. Curiously however this maximum line is inconstant in its directive influence, as will be observed upon the chart for the nights of April 20-21, 28-29, and 29-30; June 30-1 July, 1874; also for June 25-26, and August 23-24, 1876, with

several others. An example of this sudden and remarkable reversal of the earth-current upon its line of greatest force is also given in curves in Plate IV., the precise time of these changes being variable, and the changes themselves apparently spasmodic.

A series of observations were further made to discover if the same line of maximum force and its direction obtained for England, Ireland, and the Channel Islands, and the result clearly indicated that the mean line of maximum force at a given time obtains for the United Kingdom.

7. Although as a rule the earth-current variations are slow and well defined, affecting all parts of the resultant curve alike, there are periods when a portion and sometimes the whole curve is distorted from the normal condition, shown in Plates II., III., and IV. An instance of this is given at Plate V. whilst many other examples could be furnished. In some cases the disturbance affects all parts of the curve obtained from the district lying between Yarmouth and Deal; in others it is the south-west or north-west coasts that present these features. After many unsuccessful endeavours to trace these interruptions of the normal earth-current curve to exceptional wire contacts and leakages, I have designated them "Electric Storms," forasmuch as these occasional disturbances exhibit themselves for a time only, and generally over some district more or less extensive, affecting all wires radiating in that particular direction, whilst in other districts the usual curvature is maintained, together with the fact that whilst the normal current variations obey a common law the storm variations are evanescent.

This fact of distinctive normal earth-current and storm-current does not appear to be generally recognised, but, as I trust there are many who will take up more particularly the study of electric storms, I beg to describe a plan adopted by myself for more graphically illustrating their features.

It is frequently difficult to follow out readily a particular storm curve from amongst a number that cross and recross the normal line. Each curve should therefore be given upon a separate chart, thus: From the central point of observation draw radial lines in the direction of the points to which the readings have been taken,

as for instance, from London to Birmingham, Leeds, Hull, Dover, Southampton, &c.

Mark off upon these radial lines distances proportional to the strength of the currents, and connect the points by a line running through them.

Define each line + or - as the case may be. The spaces between the + lines should then be given one colour, and the spaces between the - lines another, and we at once get a graphic statement of the storm current for that particular moment of time. With the normal earth current such charts are unnecessary.

8. To obtain the dynamic value of earth-currents, it is necessary to introduce into the calculation the resistance and loss of insulation attending the particular wire, so that no general rule is applicable. It may, however, be stated that the approximate quantitative value of the earth-current along the line of greatest force does not exceed five Daniell cells, and that periods of much greater force are rare.

The daily maxima and minima are not clearly defined, but from a great number of observations there appears to be a maximum at from 10 a.m. to 11 a.m., and again between 4 p.m. and 5 p.m. Also a maximum at from 1 a.m. to 2 a.m. together with a noticeable minimum at about, or shortly after, sunrise. These phases however are not always evident; and still less do the minor variations of one series of observations bear any comparison to those of another. Careful comparisons have been made between earth current variations and the variations of terrestrial magnetism, but beyond what appeared to be the result of mere coincidence, or due to the existence of some disturbing influence, temporarily possessing a simultaneous power over both magnetism and earth-current, I have not obtained reliable indication of concurrent change.

Extensive comparisons have been made between earth-current change and the variations of wind, clouds, tides, and dew-point, but nothing suggestive of parallel effect has been elicited. With "electric storm" disturbances, however, these comparisons appear to deserve further attention.

9. Street wires do not exhibit any appreciable earth-current, *although* in one exceptional instance a slight force coinciding in

its variations with those of longer wires was apparent upon an underground line extending from St. Martins-le-Grand to Stamford Hill.

Upon short subterranean lines, that for all practical purposes are electrically perfect, weak currents, easily mistaken for earth-currents, often present themselves; but a careful examination of these currents proves them to result from slight polarised faults, the currents from which when once set up fall more or less gradually to a permanent zero.

This normal condition is produced by the current from the positive side, the fault slowly depolarising the negative, and in time effecting a balance of potential between them. Instances of this have been experienced. In one case the fault current, equal to about the $\frac{1}{200}$ of a Daniel-cell, occupied six hours and forty-five minutes in reaching the normal condition, where it remained until again set up by the application of a weak battery current; upon another occasion the same fault produced a current that occupied eight hours to reach zero. In other instances the fault has gradually reversed its polarity before gaining a permanently normal condition; in one case occupying five hours, and in another five hours and thirty minutes.

The PRESIDENT: This very interesting and suggestive paper by Mr. Adams cannot fail to raise in the minds of many a number of questions which we shall be glad to discuss with him. Some of the results are remarkably interesting, and one feels much inclined to go into them in detail, although we have only a limited amount of time; but if gentlemen have any questions to ask, or remarks to make, we shall be happy to hear them.

Mr. CHARLES V. WALKER, F.R.S.: It is some fifteen years since I dealt with the question of earth-currents, and can scarcely from memory give the results of the observations made. In the *Philosophical Transactions of the Royal Society* are several papers on this subject by Mr. W. H. Barlow, 1848, May 25; by myself, 1861, Feb. 14; by Prof. Balfour Stewart, 1861, Nov. 21; by myself, 1862, Feb. 13; by Prof. Balfour Stewart, 1862, June 19; by Prof. W. Thompson, same date; by Prof. B. Stewart, 1863,

April 6; by Sir George Airy, 1863, April 23 and Dec. 17, and 1868, Feb. 6, and 1870, Feb. 3.* A system of photographic registration of earth-currents from lines as near as may be at right angles with each other is in operation at the Royal Observatory, with which it would be instructive to compare the observations now before us. I can remember that my resultant line corresponds generally with the diagram before us. It is about north-east to south-west. I made observations at Tunbridge equidistant in a direct line between Hastings and London, and in all cases the value of the currents between Tunbridge and London was larger than the value of the same currents between Tunbridge and Hastings. The impression which occurred to me was, that the value had some relation to the conductivity of the respective masses of the earth's strata intervening, through which the currents were then passing. These are all the remarks I feel competent to make at the moment upon this very interesting paper.

The PRESIDENT: If no further remarks are to be offered, I will ask you to return your thanks to Mr. Adams for this most interesting paper, so full of facts and matter that one would like to study it thoroughly before discussing it. I will now ask Mr. Adams to read his second communication upon "The Sonorous properties of Induced Currents."

THE SONOROUS PROPERTIES OF ELECTROSTATIC INDUCTION.

By Mr. A. J. S. ADAMS, Postal Telegraphs.

During some experiments made with a slightly-modified telephone—the modification consisting of the attachment of a circular iron plate A to that pole of the magnet which was in juxtaposition to the vibratory diaphragm C—I found that by altogether discard-

* The Transactions of the Royal Irish Academy for 1861, Nov. 11 and 30, contain papers by the Rev. Dr. Lloyd.

ing the helix B of the telephone, and connecting the two secondary wires of an induction coil to the magnet A and diaphragm C respectively, the musical tone previously obtained by the use of the telephonic helix was reproduced. This result led to a number of experiments from which the following effects were deduced:

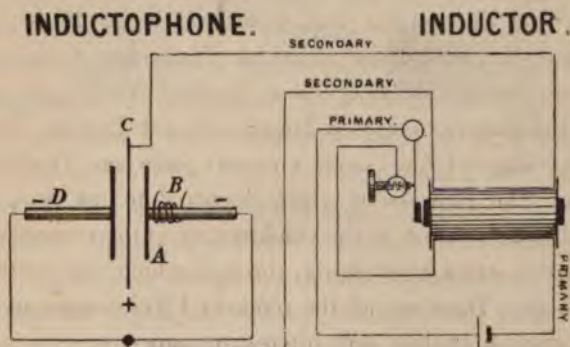

Fig. 1.

1. The closer the diaphragm C and the magnetic plate A could be brought together without loss of insulation the more intense became the sound.
2. Directly a loss of insulation occurred, even by placing the instrument in a damp position for a few hours, no reproduction of sound was attainable.
3. Whatever the pitch or tone of the reed used in the primary circuit of the induction coil, that tone would be reproduced with the arrangement already described.
4. Upon placing my body in the induced circuit it was observed that so long as the currents passed in rapid and unfelt succession the sound remained audible, but upon the occurrence of shocks to the system the sound immediately failed.

The tones emitted from this arrangement—an arrangement for which I have adopted the term "Inductophone"—were, however, much weaker than those obtained from the telephone, and an endeavour was made, first, to increase the intensity of the sound, and next to ascertain the cause of its production.

A second magnet with a circular plate D at one pole was placed

opposite the former magnet A, the two magnetic plates then being pressed closely against the iron diaphragm C, but insulated from it by paraffined tissue paper. No augmentation of sound however could be detected until the extremities of the magnets were connected by an iron strap, when to my surprise the weak tone I had previously heard at a distance of a few yards was easily discerned in any part of the large room. Whenever the strap connecting the magnets was removed the sounds became weak again, and with every disconnection or connection of the strap a bright spark appeared at the point of contact. But I was somewhat puzzled to find that if the magnets A and D were connected by copper wire, or by a wire of any other conducting material, the result was the same, namely, an increased intensity of sound. This fact was, however, of considerable value in my further researches.

The cause of this peculiar emission of sound appeared at first sight to be in some way due to magnetic force acting between the diaphragm and magnetic plates; but upon trying small sheets of tin foil, as well as plates of brass and of copper, the same peculiarity was observed, and sound could be reproduced from any of them at pleasure. The cause was evidently not simple magnetic attraction or repulsion.

Was it due to a succession of sparks rapidly passing between the plates and diaphragm? No—for the insulating tissue paper was replaced by a film of talc, which after use was examined under a microscope; but no alteration had taken place in the talc, nor was the minutest spark-perforation visible. Were the sound vibrations due to the electrostatic attraction and repulsion of the metals? Hardly, for the same effect may be produced with metal plates a quarter of an inch thick.

Accident seems to have solved the question, however, for upon one end of a coil of fine, silk-covered, and paraffined wire, wound upon an iron core, being left joined to one end of the induction coil, the other ends being disconnected, a faint but distinct sound, coinciding in tone with the inductor reed, was audible. In this case, however, it was necessary to place the ear close to the external surface of the fine wire coil, although insulated from it by a piece of tissue paper. The induction coil was in another room one hun-

dred yards from that containing the inductophone and the coil of wire.

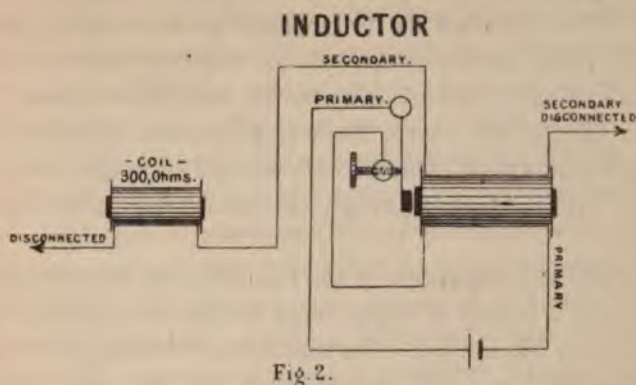

Upon connecting the plates of my inductophone to the one end of the induction coil, the diaphragm being left disconnected, precisely the same effect was produced, and it was evident to my own mind, that the sound-vibrations so curiously set up, were due to the very rapid alternating charge and discharge of the opposing surfaces, in other words to *static tension*, whilst the production of sound within the coil of fine wire may be considered analogous to the rapid charge and discharge of a submarine cable wound upon a drum. Curiously enough it was always requisite to connect one particular end of the secondary wire to the coil or plates, the other end refusing to produce the slightest ascertainable sound; moreover, placing a finger upon the end of the coil or the plate that had been connected to the secondary wire, the body being otherwise insulated, was sufficient to destroy the sound.

Of course, if the foregoing hypothesis be correct, increasing the electrostatic capacity of the plates with a given power will necessarily diminish their tension, and the sound will commence to fail. This is exactly the result obtained, for the addition of a condenser of about one farad to the experimental plates was sufficient to cause a total cessation of sound.

The difference between the telephone and the arrangement I have described appears to be this, that whilst in the former case the induced currents are transferred first into magnetic force + ∞

—, and thence into sound vibrations; with the latter, there being no intermediate means of transfer, and as the condensing surfaces are too limited to allow the development of one complete induced vibration before another is upon it, the inductive energy becomes transferred directly into another channel, namely, into sound.

Since writing the above, further experiments have shown that effects similar to those obtained with induced currents occur when ordinary power is used, although the sounds are in this instance feebler.

The plates and diaphragm of the inductophone were respectively connected to a battery of eighty large Daniell cells joined through a Wheatstone transmitter. The transmitter was caused to reverse the battery poles at a high rate of speed, and the tone emitted at the transmitter contact-points was faintly reproduced at the experimental plates.

Increasing the number of cells up to 400 gradually augmented the intensity of the sound, but the tone remained the same. With even 500 cells however the sound was considerably feebler than with the induction coil and a bichromate cell.

I have been unable to obtain any sound when the diaphragm or one end of the coil wire was disconnected, as in the case of the induced currents, but with a large number of Daniell cells every reversal of the battery poles produced a distinct and audible sound in the coil or inductophone, whether the transmitter ran at its slowest or fastest speed.

The limited time at my disposal prevents me from going deeply into this subject, but I have little doubt that the result of these experiments, so far as I am able to give them, will prove interesting to, and not unworthy the attention of, members of this Society.

The PRESIDENT: We shall be glad to hear any remarks upon the interesting observations of Mr. Adams.

Mr. W. H. PREECE: I am sure we are all very much indebted to Mr. Adams for bringing this subject before the Society, and we shall all feel also deeply indebted to any Member of this Society who will assist in endeavouring to unravel the mysteries of this very wonderful instrument. It puzzles the will and makes us *pause*. It has completely revolutionized many of our notions

regarding the effects of currents and electrical forces, and there is no doubt there are many effects of sound which have hitherto passed unnoticed that have now been brought into existence with effect through the introduction of the telephone. Not long ago a communication by telephone was tried between two points in Worcester; the wires consisting of two gutta-percha wires about two hundred yards in length. One wire had a joint in it, and this joint rested upon a carpenter's bench. When conversation was held between the two ends of this wire a person standing by heard distinctly the words uttered proceed from the bench. Now the only thing that could have caused that was the joint, possibly a bad one, that rested upon the bench. How did that joint produce sounds? I confess it puzzles me just as much as some phenomena which Mr. Adams has brought before us. However, there is no doubt that there were a variety of currents flowing. Wherever we have electrostatic induction, wherever we have induction of any shape or form, there we have those repulsions and attractions which produce vibrations, and wherever we have vibrations we have sound. Whenever these vibrations are produced in sufficient succession to each other, over 16 per second and under 38,000 per second, there we have notes.

Now, judging from the description Mr. Adams has given us to-night—and I must say I should have liked to have seen the experiments themselves performed, for it would be an advantage to the Society if Members repeated their experiments before us—judging, I say, from the description we have heard I should think these phenomena are due to the attractions of that electrostatic induction which he rather opposed, because he did not find them repeated when a plate of metal was used. I think further investigation will show that the effects are due to electrostatic induction rather than to the effects of currents or potentials. The moral of my remarks is, if any Member of the Society has experiments to bring which will aid us in any shape to unravel this or any electrical mystery, let him repeat the experiments here before us, and let us judge for ourselves of their accuracy and draw our own inferences from them.

Mr. CHARLES V. WALKER, F.R.S.: I have been making observations with Professor Bell's telephones, and had been using

them some two or three hours at stations five miles apart. The wire was an open wire on telegraph poles, on which not much business was going on. There was that peculiar spluttering sound which Mr. Preece well described as like fat frizzling in a frying-pan. In this case there was very much frizzle, and we had great difficulty in telephoning; in fact we could not hold conversation that could be called talking. A single-needle instrument helped us. We put three telephones in circuit, and three of us, one to each telephone, sang "God save the Queen," and other things, which reached the other end perfectly well. When our trials were ended all the three telephones on a table behind me could be heard spluttering loudly by induction from currents in the other wires.

Mr. J. LAISTER: I should like to ask permission to make some observations with reference to the paper read to us by Mr. Adams; for, as we are promised a general discussion on the principles of the telephone before the end of the session, it may be well to hear the result of any investigations going on meanwhile. It struck me, while Mr. Adams was describing what he called his inductophone, that one experiment which I myself tried has some bearing on the question, and may throw a little light upon it—not quite so extraordinary as the results he has seemingly obtained—but perhaps usefully suggestive to Members of this Society. It was this—having at one end of a wire a Wheatstone instrument with a simple intermittent current, not reversals, and an extemporised telephone at the other end, consisting merely of a bar magnet and a little bit of wire wrapped round the end of it, with no diaphragm whatever, and an open pill-box at the extremity, the pulsations of the Wheatstone current were distinctly heard at some distance from the mouthpiece, though I simply held the bar magnet in my hand. This result did not very much surprise me after reading the communications we have had from America, lately published in the Society's Journal, because it is there stated (though it seems to have escaped Mr. Adams) that these noises are always obtainable when an electro-magnet is under the influence of the current. We do not yet know for certain what is the cause, and I call attention to the subject as deserving closer examination. You will recollect that it was taken to be satisfactorily proved, in the communication

to which I have referred, that the sound is due to expansion, because if you place the pole of the electro-magnet upon a resonant box you get a sound from the box by reason of the expanding metal striking as it were the box, and so emitting sound. That may or may not be due to expansion, but you certainly can get the sound—as I have shown—without any resonant body for the magnet to knock against.

Mr. W. H. PREECE: I apologise for rising again. It will be in the memory of those present that when Professor Bell gave his admirable lecture here he mentioned that in Providence his friend Dr. Channing had heard upon a telephone wire, for several successive evenings, sounds of singing and portions of music. He did not then attempt to explain the phenomenon, but since then I have received an explanation of it from America, and I am sure it will interest the members if I briefly describe what happened. Professor Bell mentioned that in Providence there was a telephone circuit about a quarter of a mile long without any intermediate station upon it. Upon that wire singing and music were distinctly heard and the tunes recognised. They inquired of everybody in Providence if anybody had played those tunes. Nobody had. They then advertised the fact that for five nights certain particular tunes had been heard. It turned out that on those five nights a concert was held at Saratoga, 300 miles from Providence. It so happened that a circuit was utilised from Saratoga through Albany to New York, a distance of about 280 miles. From New York there was also a circuit 200 miles long connecting Providence, and this circuit traversed the same poles for 16 miles as the New York and Saratoga circuit. The receiver was at Saratoga. The melodies heard were sent from New York to Saratoga by means of Edison's Musical Telephone. The currents transmitted from New York proceeded along these 16 miles and there produced inductive currents on the Providence wire; they then proceeded to Providence, and there reproduced, by induction, currents on the telephone circuit, which reproduced upon the ears of those who were at the end of the circuit in Providence, music being sent from New York to Saratoga. We have in this an illustration how wonderfully delicate this instrument is. What portion of the prime currents proceeding from New York to

Saratoga produced sounds on the telephone in Providence 200 miles away it is impossible at present to say.

Mr. ADAMS [in reply]: I do not think the production of sound in this instance is due to the expansion of magnetised iron, because two pieces of tinfoil insulated by tissue paper will answer equally well. I had intended practically illustrating my experiments here, but upon maturer consideration decided that their simplicity would render the experiments out of place with the short time at our disposal to-night; and I bring under your notice the paper I have read upon the subject simply because, having a mystery to unravel, I considered this to be the proper place for its production.

The PRESIDENT: We are much obliged to Mr. Adams, not only for his paper but for raising this interesting discussion. We may hope that in the course of the session the subject will be further discussed.

ADDENDUM.

[Submitted by Mr. A. J. S. ADAMS since the foregoing paper was read.]

The following remarks bearing upon the cause of the phenomenon of sound by the action of static induction will be *apropos* to the paper recently submitted to the Society of Telegraph Engineers:—

If we accept as an axiom that abnormal static charges are developed upon the surface of bodies, and not within them, and that the effect of one static charge upon another is the tendency to move bodily one or both of the substances upon the surfaces of which the charges exist, the emission of sound in the inductophone cannot be due to this electrostatic attraction and repulsion between charged bodies, for in the case of the inductophone the plates do not move.

We have a further indication of this. Examine the inductophone illustrated at fig. 1 in the paper. Here, if when the opposing plates A and C only are used the sound waves were the product of attraction and repulsion exerted by one plate upon the other, the addition of the third plate D—acting in an opposed direction and with equal energy to the plate A—would effect a

balance of power resulting in a reduction or cessation of the sound ; but the contrary effect obtains, and the addition of the third plate D augments the sound.

The following results will, I think, offer positive proof that this phenomenon of sound is due solely to static tension, *i.e.* to the action of intermittent static force upon the atmosphere lying between the metal plates :—

Experiment 1. Insulate the respective plates by paraffined paper ; sound may now be reproduced, but, if the paraffined insulator be softened by heat and the plates pressed upon it to the expulsion of the air, sound can no longer be obtained.

Experiment 2. Place two pieces of tinfoil between the leaves of a book, with one leaf insulating them, and place the book in a copying press. Upon connecting the tinfoils to the respective ends of the inductor coil sound will be emitted ; but whenever the press is forced home upon the book the sounds will cease. The air in this case is expelled by pressure.

Experiment 3. Construct three thin flat glass cells, having merely sufficient capacity to contain a film of water ; make connection with the water inside by passing a fine wire through the circumference of each cell and seal them up. Then place the three cells in position exactly similar to the metal discs at fig. 1, and connect the centre cell by means of the wire to one end of the secondary coil, and the outer cells to the other end. Sound will now be emitted, and the fact thereby elicited that it is not necessary the opposed surfaces should be of metal. If the cell sides be caused to adhere to the exclusion of air no sound can be obtained.

Experiment 4. Place the inductophone under the globe of an air pump and obtain the sounds by placing the ear against the base-board. As the globe is exhausted the sound decreases and eventually fails ; and if the exhaustion is continued the sound pulsations will be found to have resolved themselves into those of light.

Experiment 5. A still more curious fact exhibits itself. If, whilst one of the glass cells described in experiment 3 be connected to the + end of the inductor, and the other end is left disconnected, the ear be placed near one of the flat sides of the

cell, as with the experiment illustrated at fig. 2 of the paper, a feeble sound will become apparent. The explanation of this phenomenon lies in the fact, that, whilst the coil or the glass cell constitutes one charged surface, the ear tissues constitute the other, and sound is produced in the air existing between them. If the body be insulated from the floor the effect is much the same, but if the body makes contact with earth the effect is augmented.

From these results it would appear that the conditions essential to the production of sound pulsations by means of the arrangement I have described consist of the presence of two antagonistic charges insulated one from the other by a disc of atmospheric air.

In connection with the consideration of this sonorous property of electro-statics, a few remarks upon a similar property developed by electro-magnetism will be of interest, and may explain some of the telephonic phenomena at present mysterious.

It has been thought that telephonic sound was caused by the vibration of the iron disc consequent upon the variation of attractive force prevailing at the adjacent magnet, whilst more recently an opinion has obtained that the sound-pulsations were the result of mechanical vibrations set up in the constituent particles of the disc, this latter theory being suggested by the fact, that if any body of iron, such as a piece of boiler-plate, or the girder of a bridge, be used instead of the thin iron disc at the receiving end of the telephonic circuit, the sound effects are the same. But, as it appeared questionable that sound-pulsations could be *primarily* induced within rigid bodies, although sound-waves *externally* set up may be transmitted by them, a receiving telephone was tested by a series of experiments precisely similar to those I have already described, and the conclusions arrived at by means of the results of the inductophonic experiments proved to be equally applicable to the telephone; although when in *vacuo* the telephone became silent, I was unable to transfer the sound-pulsations into those of light, probably because of the faulty vacuum apparatus at my command. It was evident, however, that the telephonic sound-waves were set up in the air-diaphragm existing between the disc and magnet surfaces, and were by no means due to molecular vibration, or to the magnetic attraction and repulsion

of one body upon the other; in other words, that for the production of telephonic sound the existence of a diaphragm of air between the magnet and disc is an essential condition.

I select two experiments :—

Varnish the opposing surfaces of the disc and magnet, and when hardened bring them together. Sounds may now be obtained, but if the two surfaces be caused to *adhere* by the application of varnish no sound can be produced.

Construct a flat narrow cell of watertight material, fasten the magnet-pole by varnish or other adhesive substance to one side, and the iron disc to the other. So long as the cell contains air the telephone will speak, but upon filling the cell with a fluid to the expulsion of the air no sound can be obtained. If, however, a flat envelope containing a film of air be immersed in the cell, sound may again be reproduced; but upon filling this envelope with oil or water, or otherwise expelling the air, the sound will again cease.

How far the twin effects of *static* and *magnetic* tension are due to one and the same cause it is difficult to define, but, although the phenomena I have described appear to have been hitherto unrecognised, they will, I think, eventually add an important page to the history of electricity.

The PRESIDENT then announced the result of the Ballot, as follows:—

President.

CHARLES WILLIAM SIEMENS, F.R.S., D.C.L.

Vice-Presidents.

MAJOR J. U. BATEMAN-CHAMPAIN, R.E.

PROFESSOR G. C. FOSTER, F.R.S.

W. H. PREECE, M.I.C.E.

CARL SIEMENS, M.I.C.E.

COUNCIL.

Members.

PROFESSOR W. G. ADAMS, F.R.S.

CAPTAIN ANDERSON, R.E.

W. S. ANDREWS.

WILLIAM T. ANSELL.

H. G. ERICHSEN.

COLONEL GLOVER, R.E.

EDWARD GRAVES.

CHARLES HOCKIN, M.A., C.E.

LOUIS SCHWENDLER, M.I.C.E.

WILLOUGHBY SMITH.

C. E. SPAGNOLETTI, M.I.C.E.

MAJOR C. E. WEBBER, R.E.

Associate Members of Council.

COLIN BRODIE.

W. M. BULLIVANT.

JOHN GRANT.

Treasurer.

EDWARD GRAVES.

Honorary Secretary.

LIEUT.-COL. FRANK BOLTON.

The Meeting was then made special, for Members only, for the purpose of considering the following proposed modification of Rules 24 and 28.

CONTRIBUTIONS OF MEMBERS AND ASSOCIATES TO THE SOCIETY.

RULE 24. After “. . . . Society,” add—“After the first of January, 1878, every Member nominated and thereafter elected into the Society shall pay an Entrance Fee of Two Guineas, and every Foreign Member or Associate One Guinea.

“Each Member so elected (or transferred from the class of Associate) shall contribute the sum of Three Guineas, and each Foreign

“ Member or Associate Two Guineas, annually to the Society. All
 “ Members and Associates who have been elected into the Society
 “ previous to this date to be considered as Original, and continue to
 “ pay the original contribution. The Certificates to be inscribed
 “ accordingly, and the distinguishing letters O. M. or O. A., as the
 “ case may be, placed opposite to each in the List of Members.”

RULE 28 to be modified as follows :—

An Original Member may compound for his annual Subscription by the payment in one sum of Twenty-one Pounds; an Original Foreign Member or Associate by the payment of Ten Pounds.

The Composition Fee of Members elected or transferred from the class of Associates, under the conditions indicated in paragraph 2, Rule 24, to be Thirty Pounds, that of a Foreign Member or Associate similarly elected to be Twenty Pounds. All such, &c.

Mr. Gavey and Professor Hughes having spoken, it was moved by Mr. R. K. Gray, seconded by Mr. Latimer Clark, and carried, That Rule 24 be amended as follows, viz. :—

RULE 24. After “. . . . Society,” add—“ After the
 “ first of January, 1878, every Member nominated and thereafter
 “ elected into the Society shall pay an Entrance Fee of Two
 “ Guineas, and every Foreign Member or Associate One Guinea.”

It was then proposed by Lieutenant-Colonel Bolton, and seconded by Captain Anderson, R.E., That—

“ Each Member so elected (or transferred from the class of
 “ Associate) shall contribute the sum of Three Guineas, and each
 “ Foreign Member or Associate Two Guineas, annually to the
 “ Society. All Members and Associates who have been elected
 “ into the Society previous to this date to be considered as Original,
 “ and continue to pay the original contribution. The Certificates
 “ to be inscribed accordingly, and the distinguishing letters O. M.
 “ or O. A., as the case may be, placed opposite to each in the List
 “ of Members.”

To which the following amendment was proposed by Mr. Gavey, and seconded by Mr. Graves :—

“ That no alteration be made in the future annual payment.”

Whereon the following further amendment was moved by Mr. Preece:—

“That the proposed alteration in the annual subscription be referred back to the Council for reconsideration.”

Which amendment was put to the meeting and carried.

It was announced that Mr. James Laister and Dr. Alexander Muirhead, F.C.S., had been transferred from the class of Associates to the class of Members, and that Mr. Theodore Charles T. Walrond had been transferred from the class of Students to the class of Associates.

The following new Candidates were balloted for and elected:—

FOREIGN MEMBERS :

Mr. Dwight.	Capt. Heinrich Honeke.
M. Felix Careme.	Mr. Leonard Brindisi.
Mr. Carl Mulrad.	M. Paul Jablochkoff.
Don Primitivo Vigil.	Mr. Hy. Augustus Severn.
Don Enrique Iturriaga.	Lt. Gustav Adolph Tobler.
Don Vicente Coromina.	Mr. Timotheus Rothen.
Don José Galante.	Mr. Hy. von Hovenburgh.
Mr. J. S. K. Hopstock.	Mr. Ed. von Hosslin.
Mr. J. A. P. Peterson.	Mr. A Knoll.
Mr. Christian Adrian Schultz.	

MEMBERS :

Mr. Richard Wm. Henry Paget Higgs.
 Mr. John Euston Squier.
 Stephen D. Field.
 Mr. Angus Grant.
 Mr. J. H. Elleby.
 Lieut. W. P. Shakespear, R.N.
 Mr. Thos. W. Porritt.
 Major Robert Murdoch Smith, R.E.
 Col. R. Murray.
 Professor Alexander Graham Bell.

ASSOCIATES :

Mr. C. Chevallier.	Mr. Chas. Hy. Wilson.
Dr. Elam.	Mr. Hy. Clipperton.
Mr. W. R. Anderson.	Mr. D. Pigeon.
Mr. Walter Bolton.	Mr. W. W. Vyle.
Mr. Alfred Atkinson Jordan.	Mr. Alfd. Langman.
Lieut. F. W. Bennett, R.E.	Lieut. W. G. Addison, R.E.
Mr. Thos. A. Croal.	Mr. James Smith.
Mr. George Raymond.	Mr. J. D. R. Stuart.
Mr. Archd. Christie.	Mr. J. D. Doyle.
Mr. Hy. Dennis Hasdell.	Mr. Arthur R. Simkins.
Mr. James Howell Turner.	Mr. James Wright.
Mr. Frank A. Taylor.	Mr. James Davis.
Mr. Hy. Ponder.	Mr. James O. Fry.
Mr. Rd. Bradley.	Mr. George M. Gilbert.
Mr. John Fletcher Moulton.	Mr. Thos. Harrison.
Mr. George Smibert.	Mr. Alfd. James Frost.
Capt. A. H. Richardson.	Capt. Hamilton Geary.
Mr. F. Bolton.	Mr. Walter Teale.
Mr. W. Bosomworth.	Mr. William Oliver Jones.
Mr. Arthur Reade.	Mr. W. Standford.
Mr. Fredk. Westley Dyer.	Mr. H. May.
Mr. Herbert R. Edmonds.	Mr. D. Anosi Falch.
Mr. Hy. Windeler.	

STUDENTS :

Mr. Arthur F. St. George.
Mr. Leopold D. Barclay.
Mr. Alfd. Chas. Monckhouse Weaver.
Mr. Thos. D. F. Andrews.

The meeting then adjourned.

OBITUARY.

MAJOR-GENERAL D. G. ROBINSON.*

Major-General Daniel George Robinson, R.E., whose death took place on the 27th July, 1877, on board the "Travancore," when returning to India, was born in the city of Mexico on the 8th of March, 1826. Taking military service at the early age of 17, he received his first appointment to the Bengal Engineer Corps in June, 1843. Serving as Assistant Field Engineer he was present at Sobraon, obtaining the Sutlej Campaign Medal, 1845-6. On the break-up of the army of the Sutlej he was appointed to command three companies of Sappers and Miners at the siege of Kangra; proceeding at its surrender in command of the escort of the Boundary Commissioner, he made a military survey of the country on either side of the Jummoo and Lahore boundary from the Beas to the Indus. In recognition of the value of this survey, on the recommendation of Sir Henry M. Lawrence, he received orders from Lord Hardinge to organise and carry out a survey of Hazara. In 1848, the progress of the work having been interrupted by the outbreak of the Sikh army, he was employed as Assistant to the Resident at Lahore in blockading the Sikh Brigade in Upper Hazara, and afterwards, as Assistant Political Agent with Lord Gough's army, was present at Chillianwala, Gujrat, the surrender of the Sikh army, and the re-occupation of Peshawar; receiving the medal and clasp, as well as the thanks of the Governor-General in Council. Returning to Hazara he completed its survey, after which he was placed under the orders of the Surveyor-General as First Assistant in the General Trigonometrical

* Partially extracted from "The Pioneer" newspaper, published in India.

Survey, his first work in the department being a detailed survey of the boundary between Lahore and Jummoo, for which he received the thanks of Government. From 1851 to 1860 he was employed on the Topographical Survey of Khistan and the Sind Saugor Doab. This was declared to be the best topographical survey ever executed in India, and was made the model for all others subsequently undertaken. In 1857 he assisted in the repulse of an attack on the Murrée sanitarium, was honourably mentioned in the Punjab report on the outbreak in that province, and received the Mutiny medal. Between 1860 and 1863 he was engaged in surveying the Native States of Central India, and received the special thanks of Government. From October, 1863, to February, 1865, he officiated as Superintendent of the Great Trigonometrical Survey, afterwards acting for a few months as Deputy Surveyor-General and Superintendent of Revenue Surveys.

It was in July, 1865, that Major-General--then Colonel--Robinson was appointed Director-General of Telegraphs in India. Three months later, in compliance with the order of Government, he submitted a complete scheme for the reorganization of the Department, in sanctioning which the Governor-General in Council observed that "the report submitted by Colonel Robinson is a good and useful one. His views appear to be generally moderate and sensible, and to give promise of an energetic and effective management of the Department." This re-organization took effect from the 1st January, 1866, and included the grant of largely enhanced powers to Divisional Superintendents and Executive Officers; the removal of the task of compiling accounts from those officers to a central office in Calcutta; the more systematic examination of messages in the check office; and a material improvement in the pay and prospects of the signalling establishment. Proceeding to England on sick-leave in March, 1866, after serving continuously in India for twenty-two years, Colonel Robinson worked out the introduction of telegraph stamps; did much to improve the class of telegraph material shipped to India; procured the admission of his Administration as a party to the International Telegraph Convention, and introduced that most successful system, which still obtains, of recruiting the

higher grades of the department by a system of limited competition, as well as for practically training successful candidates before they leave England.

Returning to India in February, 1868, he shortly obtained the approval of the Government to the appointment of Director of Traffic and Construction, in place of a second Deputy Director-General—a division of labour which has worked admirably. His next scheme was to train and employ soldiers as signallers wherever practicable, and up to this time some three hundred men have been taught Morse signalling, and about fifty are regularly employed in telegraph stations. Up to 1868 the Indian telegraph tariff was based on a system of zones. Colonel Robinson, with the sanction of the Government of India, then introduced the important experiment of a low universal rate—one rupee for ten words, including address; which tariff proving financially unsuccessful, the existing charge of one rupee for six words with a free address was adopted. India was thus some years ahead of England in adopting a universal charge, and, although one rupee for six words may appear high in comparison with a shilling for twenty, it must be borne in mind that the average of telegrams in India traverse nearly a thousand miles for every hundred in the case of those within the United Kingdom, while the establishment and maintenance of telegraphs in the former are very much more costly than in the latter. Prior to Colonel Robinson's administration the minimum charge for a message from Calcutta to Bombay was four rupees, to Kurrachee five rupees, to Madras three rupees; it is now one rupee in each case.

In 1869 the Ceylon telegraphs were added to Colonel Robinson's charge. In 1872 the Government sanctioned the transmission of messages for publication in newspapers at one quarter the ordinary rate; during the first year the revenue derived from such traffic was 11,664 rupees against 30,026 rupees in 1876-77.

Colonel Robinson represented the Government of India at the International Telegraph Conferences held at Rome and St. Petersburg in 1871 and 1875 respectively; throughout 1876 he was on duty in England arranging with the directors of the several Indian Railway Companies for the purchase or working of their telegraphs, a measure which he had strongly urged on the Government of

India, and thus alluded to in his Administration Report for 1873-74: "It costs little more labour or expense for the assistant superintendent who has executive charge of 400 miles of Government wire and a few offices along a railway to also maintain that railway's wires, but it is manifestly to the pecuniary advantage of both Government and railway that he should do so." This, the last but by no means the least of the more important measures initiated during Colonel Robinson's administration, is now being satisfactorily carried out. The Government Telegraph Department, in addition of course to State Railway wires, now maintains the telegraphs of the East India, Great Indian Peninsular, Scinde, Punjab, and Delhi, Bombay and Baroda, and Oudh and Rohilcund Railways, while agreements to similar effect have already been or are on the point of being concluded with the Madras, South India, and Eastern Bengal lines. The vast growth of the Telegraph Department during the twelve years of Colonel Robinson's administration may be briefly summarised thus: The number of stations increased from 159 to 237, in addition to which its officers held the technical supervision of 419 railway telegraph offices; the length of open lines including those rented to railways was enhanced by nearly 5,000 miles, that of wire by 25,000 miles; the number of paid messages disposed of annually increased from 2 $\frac{3}{4}$ lakhs to 11 lakhs, and the message revenues from 11 $\frac{1}{2}$ to 27 $\frac{1}{2}$ lakhs of rupees.

Mr. Albert I. L. Cappel, in a letter addressed to the Acting Secretary, observes:—

"In India, as elsewhere, the substitution of exact knowledge for the rule-of-thumb procedure of former times has vastly increased the technical efficiency of the service, an improvement mainly due to the foresight of the late Director-General in surrounding himself with able professional assistants. He also recognised at the outset of his administration how much of its success must depend upon the acquisition of a really intelligent, contented staff of signallers; and by kind, considerate, and consistent treatment, and by holding out inducements to all classes to study, he secured an admirable staff of capable subordinates, of whom he was justly proud. Indeed to him alone is due the credit for whatever success has been achieved in this country, for he not only possessed the power

of organization in a very high degree, but also the much rarer faculty of securing for all his measures the enthusiastic and devoted support of his principal officers, and the hearty co-operation of all.

“It has been a melancholy satisfaction to me to receive from so many sources proofs of the high estimation in which he was held by those who knew him or were acquainted with what has truly been his life’s work; and I beg you to express to the President and Council of your Society my personal thanks, and those of my colleagues in the direction, for the kind expressions you have used in referring to our late chief and friend.”

We feel that it is impossible by any words which we can pen to add one atom towards that high reputation, that deep and well-earned respect and love, which the active, zealous, and indefatigable mind of him, now with us no more, has earned from all by whom he was known, either in person or name. He aimed to establish the telegraph service of our Eastern Empire upon a basis which should be alike honourable to the Government and to the officer. How well he has succeeded in this may be learnt from the high reputation which his department has earned for itself. From the foundation of the Society he has displayed a lively interest in its welfare, and has ever sought to extend its influence amidst those whose welfare was to him as much a matter of interest as though the tie which bound them together were that of kin rather than of service.

RUHMKORFF.

We regret to record the sudden death, on December 20, at Paris, of Henry Daniel Ruhmkorff, whose name is so closely connected with the history of magneto-electricity. He was born in Hanover, Germany, in 1803, and but little is known of his early life. In 1819 he wandered to Paris, and obtained a position as porter in the laboratory of Professor Charles Chevalier, at that time one of the leading French physicists. Here he displayed a remarkable fondness for electrical apparatus, as well as ingenuity in its arrangement, and was enabled shortly after to start a modest manufactory of physical apparatus. Through the efforts of Chevalier and the excellence of the work performed, the business

was rapidly extended. In 1844 Ruhmkorff brought out his first invention, a convenient thermo-electric battery. Soon after he turned his attention to magneto-electricity, especially the production of the induced currents, discovered by Faraday in 1832. A long series of experiments resulted in the appearance, in 1851, of the famous "Ruhmkorff coil," with its later modifications, the most important piece of apparatus in this branch of physics. With this powerful adjunct the electrician was enabled to obtain sparks 18 inches in length, pierce thick plates of glass, and carry out a vast variety of experiments. This invention was rewarded by a decoration and medal at the Exhibition of 1855, while in 1858 it received the first prize of 50,000 francs at the French Exhibition of Electrical Apparatus. Since then the manufacture of the coils and of electrical machines in general has assumed enormous dimensions, and the leading physicists of Europe are well acquainted with the dingy little bureau in the Rue Champollion, near the University. Personally M. Ruhmkorff was of a quiet, dignified appearance, and, despite the disadvantages of his early life, he enjoyed the friendship of the leading Parisian *savants*, and was an honoured member of the French Physical Society. M. Jamin delivered an address over the grave, in which he stated that Ruhmkorff died almost a poor man, because he had spent all his earnings on behalf of science and in works of benevolence.—*Nature*, December 27th, 1877.

ORIGINAL COMMUNICATIONS.

RESEARCHES ON SELENIUM.

By Dr. ENGEN OBACH.

As early as May, 1875, Dr. Werner Siemens communicated to the Academy of Science of Berlin a preliminary note of his researches on selenium, in which he pointed out that crystalline selenium has different properties according to the temperature at which it has been prepared.

Modification I., prepared at a temperature of 100° C. is susceptible to light, and shows, under all circumstances, an *increase* of conductivity with increasing temperature.

Modification II., prepared at a temperature of 210° C., is a much better conductor of electricity than Modification I., is also much more sensitive to light, and shows the remarkable phenomenon that its conductivity *decreases* with rising temperature, at least within certain limits.

The selenium preparations had, in order to offer a large surface to the light, the following construction: Two gratings of platinum

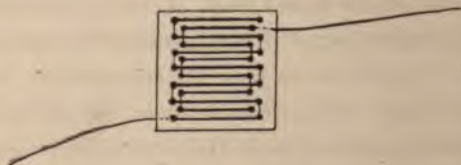

wire, of about 0.1^{mm} diameter, were laid and fixed upon a small plate of mica, as shown in diagram, so as not to touch each other.

The interstices between the parallel wires were filled with molten selenium, which was subsequently treated in the manner necessary to change it into the crystalline condition required.

Dr. Siemens concluded from his experiments that the action of light upon the conductivity of selenium varied approximately as the square root of the light intensity, and proposed to use sensitive selenium preparations for photometric purposes.

A selenium photometer was exhibited and explained at a meeting of the Berlin Industrial Society the following June.

This instrument consists of a sensitive selenium plate fixed at one end of a short tube, which can be rapidly turned at right angles to its longitudinal axis, the motion being limited by two stops placed at an angle of ninety degrees. When resting against the one stop the selenium plate is illuminated by the light to be measured, and when resting against the other stop by a standard candle, the distance of which can be changed and read off on a scale. The plate is connected with battery and galvanometer, and the distance of the standard candle regulated until both lights give the same deflection on the scale of the galvanometer.

The ratio of the squares of the distances of the two lights from the selenium gives the ratio of their intensities.

In a paper read before the Academy in February, 1876, Dr. Werner Siemens gave a more detailed report on his researches, and on Friday, February 18th, of the same year, Dr. C. W. Siemens delivered a lecture at the Royal Institution on this subject.

After some introductory remarks on the history of selenium, Dr. Werner Siemens tells us in his paper, first of all, that he was not able to discover any action of light upon the conductivity of other materials than selenium, tellurium not excepted. Then an experiment is described which shows that, if amorphous non-conducting selenium is gradually heated, a considerable liberation of heat takes place at 80° C. At the same time the selenium is changed into a crystalline state, and becomes a conductor of electricity. As the temperature rises more and more the conductivity increases rapidly, and reaches a maximum at about 210° C. At 217° C. the selenium melts, and the conductivity diminishes with equal rapidity. If the temperature of the molten selenium is raised the conductivity

increases again up to temperatures at which the material begins to evaporate.

The conductivity of the crystalline modification which results when amorphous selenium is kept for some time at 150° C. increases with the temperature, following a line whose curvature is always towards the same side. The equation which Dr. Frölich found for this curve shows the interesting fact that the increase of conductivity for two succeeding temperatures is proportional to the conductivity itself.

In the course of these experiments it was noticed that the conductivity of some selenium plates slowly diminished when they were kept for some time at a temperature near 200° C. This led Dr. Siemens to think that there might probably be a relation between this decrease of conductivity and the curious fact that amorphous selenium is thoroughly changed in its physical properties when maintained at that temperature for several hours. Experiments made to clear up this question have shown that selenium kept at 200° to 210° C. until the conductivity no longer decreases behaves as a metallic conductor, and the conductivity increases as soon as it begins to cool.

If the heating at 200° C. should not be maintained long enough, the conductivity decreases, first when cooling, until a certain temperature is reached, from which it increases again. This temperature depends upon the time of heating.

To obtain these results it is necessary to heat the amorphous selenium rapidly to 200° C.

The crystalline modification, which is obtained when the molten selenium is cooled to 210°, and maintained at that temperature for some time, and which is marked as Modification III., behaves like selenium prepared at 100° C., that is, like an electrolytic conductor.

An approximate determination of the specific conductivity of these three crystalline modifications of selenium, mercury taken as unit, gave the following figures :

Modification I.	$\frac{1}{1.4 \text{ billions.}}$
Modification II.	$\frac{1}{4,000 \text{ millions.}}$
Modification III.	$\frac{1}{80,000 \text{ millions.}}$

Prof. Adams observed that the resistance of crystalline selenium depends upon the number of cells used for the measurement. Dr. Siemens found that only selenium prepared according to Modification II. shows this influence of the battery-power, and that the resistance of Modification I. is very nearly the same if measured with one single cell, or with 15 cells.

The current itself acts more or less upon the conductivity of selenium in the same direction as heat does. Some of the preparations gave signs of polarisation, whilst others showed no polarisation at all. These phenomena are very changeable and difficult to predict; they seem to be intimately connected with the time that has elapsed since the plate has been prepared.

They are much like those described by Hittorf for proto-sulphide of copper, and those noticeable with faulty submarine cables and with so-called unipolar conductors, such as soap, &c., in which case they are due to an electrolytic change of the materials near their contact with the electrodes.

When submitted to any change of temperature selenium behaves in a very strange manner. If a preparation of Modification II. is brought either to a higher or to a lower temperature its conductivity changes at once accordingly, but in both cases it then gradually diminishes. It sometimes happens that if one of these preparations is maintained for a longer time at -10 to -15° C., the change from metallic to electrolytic conduction, which usually occurs at a temperature of the higher than the ordinary temperature of the air, takes place at a lower one, or even vanishes entirely, in which case a plate originally belonging to Modification II. obtains the properties of Modification I.

If the first modification is subjected to a change of temperature it shows in so far a greater regularity, as in either case the conductivity gradually reaches the limit corresponding to the increased or decreased temperature.

Another interesting fact is, that the resistance of some of the plates of Modification II. varies with the direction in which the current passes. This exceptional behaviour occurs particularly if the two metal electrodes in contact with the selenium are of very different size, or if both are not in intimate contact with the selenium,

In one experiment the resistance of a selenium plate, furnished with two gratings of 10 and 20 parallel wires, was found to be twice as great if copper was connected to the 10-wire grating than if it was in connection with the 20-wire grating. It seems therefore as if the resistance of this plate depended mainly upon the size of the positive electrode. The plate did not show any polarisation current.

No variations of this kind have been found with plates belonging to Modifications I. or III.

The theoretical conclusions drawn from these experiments are very important, but to prevent repetition I think it better to deal with them after I have communicated some further results.

Dr. C. W. Siemens demonstrated in his lecture at the Royal Institution the action which heat exercises upon the different modifications of selenium by means of experiments and diagrams. He showed graphically the effect which different sources of light produce upon sensitive selenium. A table was given from which it follows that selenium, if exposed to the different colours of the spectrum, is not sensibly affected by the ultra-violet (the actinic) part, whilst the red rays produce the maximum effect.

In the course of his lecture Dr. Siemens described the selenium photometer, which was exhibited on the lecture table, and which I have already mentioned. He also made some experiments with an ingenious little apparatus representing the human eye. It consisted of a hollow ball with two openings opposite each other. One opening was furnished with a glass lens, and the other was closed by a sensitive selenium plate taking the place of the retina. Sheets of differently coloured paper were placed in front of this artificial eye, and the action upon the selenium, which was in accordance with that of the different colours of the spectrum, was shown to the audience by means of galvanometer deflections projected upon a screen.

In a communication to the Academy of Berlin in June last, Dr. Werner Siemens deals again with the question—if other conductors of electricity than selenium are influenced by light. This was caused by the result of a series of experiments which Dr. Richard Bornstein of Heidelberg had published in the meantime, and which

seemed to prove that the conductivity of platinum, silver, and gold, is acted upon by light.

Dr. Siemens repeated Bornstein's experiments with the greatest care and with highly-sensitive instruments, but was not able to find the slightest action of light upon these metals. The same negative results were obtained by Mr. Gustav Hausemann of Berlin.

After having expressly emphasised that even after repeated experiments he could not observe any action of light upon tellurium, Dr. Siemens describes some experiments which he made to determine whether selenium can be used for exact photometric measurements or not.

The selenium preparations used for that purpose were of the construction already described. They had a resistance from 500,000 to 1,500,000 mercury units, and were fixed into the tube of the photometric apparatus.

Four candles were placed side by side at a distance of 100 centimetres from the selenium plate, and the standard candle shifted until both galvanometer deflections were the same. The distance of the standard candle was then 49.1 centim. instead of 50 as it should have been according to the law of inverse squares.

The comparison of a paraffin lamp with a standard candle and of two different lamps with each other, by means of the selenium photometer, at different distances, has shown that this instrument gives, even without great care, results of sufficient accuracy for practical purposes.

Dr. Siemens thought it at first possible to construct a selenium photometer which gives a direct indication of the light intensity, but in the course of his experiments he found that the conductivity of selenium depends upon too many factors, which are too far beyond control to render it suitable for such direct measurements. These factors include particularly the length of time during which the selenium is acted upon by light.

If Modification I. is illuminated for some time by a light of constant intensity, the conductivity gradually increases, even for an hour and more according to its preparation. If Modification II. is constantly illuminated it behaves quite otherwise in so far as the

conductivity reaches a maximum within a few seconds, and then gradually decreases for more than one hour.

Dr. Siemens terms this occurrence the "fatigue" of the selenium.

This effect of the length of time of illumination is different for the different preparations, and makes it very difficult to ascertain an exact relation between the intensity of light and its action. Numerous and varied experiments did not give results agreeing sufficiently, but they have shown that the action of light upon selenium increases in a lower ratio than that of the square roots of the light intensities.

One of these experiments, in which by means of a double refracting prism of Iceland spar two beams of light of exactly the same intensity were thrown, either each one separately, or both together, upon the selenium, gave the result that the action of light is nearly proportional to the cube root of its intensity.

The several colours of the spectrum act differently upon selenium as we have seen, and the selenium-photometer cannot therefore be used for the comparison of differently-coloured light without correction, but nevertheless it has, beyond all others, the advantage of giving a distinct quantity for light of all colours.

The *value of illumination* of two lights of different colours is the same if both enable us to recognise distant objects with the same degree of clearness.

Dr. Siemens intended to ascertain empirically this "value of illumination" for the different colours of the spectrum, and to compare it with the effect exerted upon selenium, so as to obtain the co-efficients of colour-correction for his photometer, but he was not able to get satisfactory results owing to the very great difference in the perception of light of different observers.

I now have to make some few remarks about the theoretical conclusions which Dr. Siemens draws from his researches and about the explanation he gives for the interesting behaviour of selenium.

Dr. Siemens considers amorphous selenium, as well as crystalline, to be an allotropic modification of a hypothetical metallic state, which is, like other single metals, free from latent heat; but, whilst the metals absorb latent heat only at a change of state, selenium is *able to do* this at all temperatures below 200° C.

If amorphous selenium is heated, a part of its latent heat is liberated at 80° C., and the remainder at 200° C. The presence of latent heat is, as otherwise stated, a kind of obstacle to the passage of the electric current.

The increase in conductivity which certain selenium modifications show with rising temperature, can therefore be explained by the assumption that the latent heat of this substance gradually diminishes with increase of temperature. Modification II. contains less latent heat than Modification I., and it is accordingly a better conductor; it is to be considered as a mixture or a compound of the hypothetical metallic with the crystalline modification.

It is not possible to change selenium completely into the metallic modification, because this is not a stable condition at ordinary temperatures, but returns partially during cooling to the crystalline modification, while a re-absorption of latent heat takes place. The portion which remains as metallic selenium is either mixed or combined with the crystalline modification. This case is analogous to the fact that oxygen can never be changed into ozone more than to a certain limited amount.

If selenium is exposed to light, the crystalline state of the parts of the surface, and to a certain very small depth, is reduced more or less to the metallic state, under liberation of heat, which state is changed back again as soon as the illumination ceases. The action of light upon selenium is therefore similar to that of heat.

For the explanation of the curious phenomena of "fatigue" we have to assume that the crystalline selenium is more transparent than the metallic.

At the first instant of illumination the action of light penetrates to a certain depth, and changes the crystalline state into the metallic state of greater conductivity. As soon as the surface is covered with a continuous metallic coating, the same acts as a screen, which prevents the light meeting the parts situated at a greater depth, which therefore change back into the crystalline state. It can easily be ascertained that the action of light takes place only at the surface of the selenium by comparing the effect which light produces upon the two different sides of a selenium plate. Owing to the kind of preparation of these plates, the wire

gratings touch on one side the mica plate whilst on the other they are covered by a thin layer of selenium.

The action of light upon the first side is twice or thrice that upon the second. The much greater and speedier effect which light exercises upon Modification II. than upon Modification I. may be explained possibly by the smaller quantity of selenium which is to be reduced by light to the metallic state with the first-named modification than with the second, partly to the fact that the metallic surface formed by light is only at some few points in contact with the metal electrodes, so that nearly everywhere the current has to pass a layer of selenium not changed into the metallic state.

I beg to apologise for the length of these remarks, and to offer as excuse the interest taken in the remarkable and exceptional behaviour which distinguishes selenium from all other conductors of electricity.

A NEW AND PRACTICAL APPLICATION OF THE TELEPHONE.

By ELISHA GRAY, Sc.D.

In a former article on the transmission of electrical vibrations I discussed the subject somewhat generally, so far as the science at that time had been developed. Since then great strides have been made in the matter of utilizing, for practical purposes, the facts brought out by a long series of experiments.

I shall not, in this article, attempt to give all that has been done in this line of investigation by others, as well as myself, but only refer to two applications that I have made of telephonic transmission.

First, I will describe a system of multiple telegraphy that has for some months been in operation experimentally on different lines of the central division of the Western Union Telegraph Company,

About December or January, 1874, I spent a few days with Supt. C. H. Haskins, of Milwaukee, experimenting on the North-Western lines. It was suggested by him that a combination of telephonic and Morse transmission might be effected by the use of resistance coils at the Morse stations. No experiments were tried at that time, but at a later date, in 1875, during another visit, we tried the experiment on a short circuit, with only indifferent success, as there was much yet to learn in the matter of transmitting electrical vibrations before they could be successfully applied in this way. For some months following my time was all taken up in other applications of the system, and it was not until the fall of 1876 that I seriously turned my attention to this combination.

The object I sought to accomplish was to take an ordinary way wire with many offices—ten or twenty, as the case might be—and make a through wire of it at the same time; *i.e.*, to work the Morse offices as usual, and at the same time be sending through messages without interfering with the ordinary way working.

The first attempt on a long line developed the following difficulties:—

1st. When the battery, or any considerable portion of it, was thrown in vibration, the working margin on the line was reduced to the extent of about 40 per cent. of the power of that portion of the battery thrown in vibration. This rule is varied by the rate of motion and the adjustment of the contact at the point of interruption. This increase and decrease of force was sufficient to work the Morse relay, or at least to so derange its balance as to practically prevent its working. To overcome this difficulty I devised a compensating arrangement by which an amount of battery equal in strength to 40 per cent. of the vibrating battery was taken off whenever the key that threw the vibrations to line was opened; so that the line, when the Morse key was closed, had always the same current strength, whether smooth or in vibration.

When arranged thus there was no tendency either to close or open the Morse relays in the circuit; but there was a tendency to jar the Morse armature, and render the signals somewhat broken.

Another trouble was experienced in the fact that the relays on the line mutilated the vibrations, owing to extra currents created by the charge and discharge of the magnets, so that any considerable number of them in a circuit would so interfere with the vibrations as to reduce them below a practical working point. These difficulties were overcome by the arrangement shown at fig. 1, middle station, which will be described further on.

The practical application of the principles involved in preserving an equilibrium on the line when telephonic transmission was going on, underwent many changes; but finally I settled upon the plan shown in fig. 1, as producing in all respects the best results.

In the month of May, 1877, I equipped one of the Western Union Telegraph Company's wires between Chicago and Milwaukee, a distance of 87 miles. This wire had only two Morse and two telephone offices. The experiment was sufficiently successful to warrant a further trial on a longer wire. Through the kindness of the officials of the Western Union Telegraph Company I was assigned a wire from Chicago to Indianapolis, having four Morse and two telephone offices. At first we worked the telephone side, or "phantom wire," between Chicago and Indianapolis, for through business, while the Morse was used as usual between Chicago, Lafayette (Indiana), and Indianapolis. Inasmuch as there was more business between Chicago and Lafayette, a way station of importance, and as it would demonstrate another capability of the system, it was decided to put a telephone station at the latter place. This was done without introducing any main battery, and the wire was worked for a number of weeks, the Morse side doing way business between Chicago, Lafayette, and Indianapolis, while the telephones did the Commercial News business between Chicago and Lafayette, a distance of one hundred and thirty miles. The whole length of the line was one hundred and ninety miles.

I was then assigned a way wire from Chicago to Dubuque, Iowa, a distance of one hundred and eighty-nine miles, with seventeen Morse offices. These seventeen offices are now doing business with each other as usual, while at the same time Chicago and Dubuque are doing all the through business between those two *points* without interfering with the ordinary way business—a

practical result, I venture to say, accomplished for the first time in the history of telegraphy.

The details of this system of way and through working, or double-way working, on the same wire, I will now explain, and in doing so will refer to the diagram :

The plan shows three Morse and two telephone sets of instruments. The end stations are exact counterparts of each other in all the details, both of circuits and of apparatus. Each end station has a complete set of Morse and telephone apparatus. The middle station shows a Morse set alone, and is like, in every respect, each of the other sixteen Morse stations on the line. We will now describe the apparatus shown at the right-hand end station. The batteries are connected to line in the same manner as in the ordinary closed circuit Morse system. The instrument marked G (right-hand end station) is a telephonic receiver or analyzer. The principle of this instrument is fully described in *Prescott's Electricity and the Electric Telegraph*, page 879, fig. 522. Briefly, it consists of a common electro-magnet, having one end of a steel armature made fast to one of its poles, while the other end extends over the other pole, but not in contact with it. This armature is tuned to vibrate at the rate of about three hundred times per second. A small secondary lever, having one end pivoted, while the free end rests on the free end of the tuned armature, serves to control the local circuit, which actuates a common sounder.

When the tuned bar is thrown in vibration, the secondary lever jars upon it, because its natural rate of motion is slower than that of the bar, and hence cannot follow it.

If a local circuit is passed through the two levers, as shown in the diagram, it will be opened when the bar vibrates, and will close again when it is at rest. The operation of this will be explained further on. K No. 2 is a common Morse key, and M a common relay; $\frac{R}{C}$ is a small condenser and rheostat combined, and they are both inclosed in the same box.

The condenser and rheostat are both connected around the key

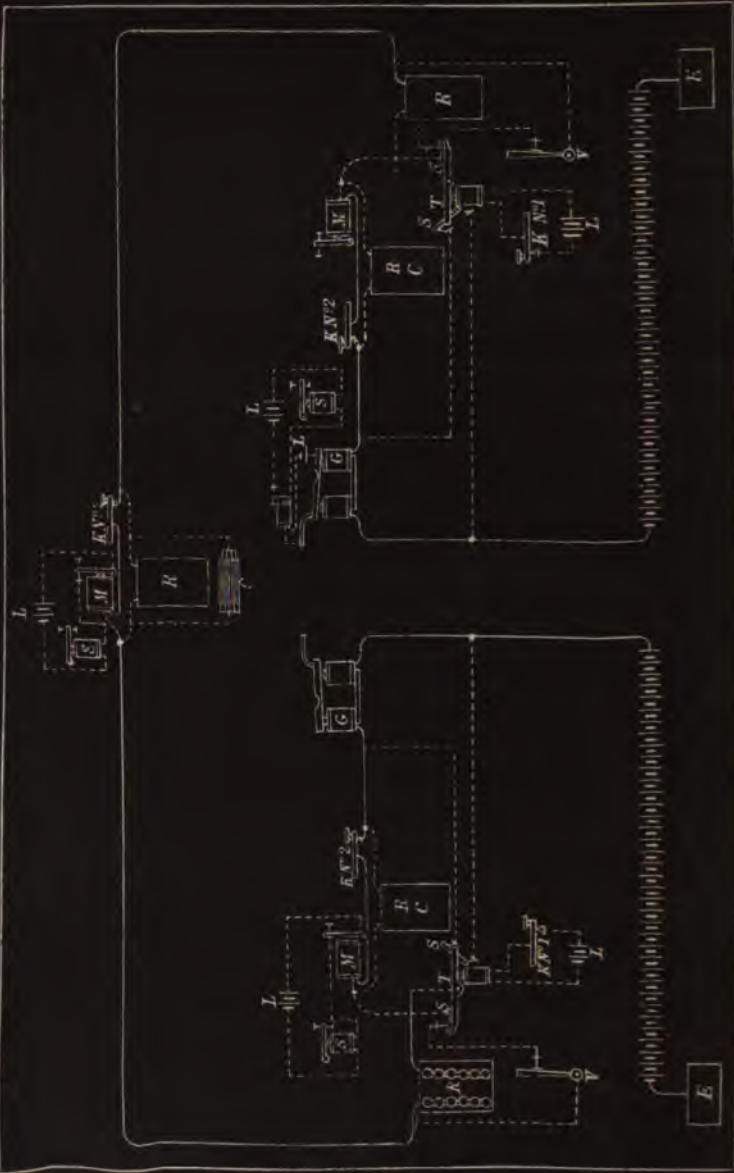

and Morse relay. The middle station shows the connections more clearly. The resistance in rheostats at the Morse stations is 6,000 ohms each. More or less may be used, according to the length and resistance of the telegraphic circuit. T is a transmitter, similar in principle to the Stearn's duplex transmitter, and is operated by a local battery and key, K No. 1. On one end of the transmitter lever is a spring S, which is insulated from the lever, and serves to throw a shunt around the receiver G when the transmitter closes. V is a vibrator kept in constant motion during working hours by means of a local battery. This vibrator is tuned in unison with its corresponding receiver at the other end of the line. R is an ordinary rheostat; K No. 1 is an ordinary sending-key, and works the transmitter by means of the local battery L.

I will now describe the operation of the two systems of working—first, the No. 1, or telephone side, and secondly, No. 2, or Morse side. The sides are numbered for convenience.

When the right-hand station wishes to communicate by telephone with the other end, he writes ordinary Morse characters with key No. 1. Every time the key is depressed the transmitter lever is attracted, and the spring S'—which is insulated from the lever at one end—is brought in contact with a point, which at the same moment causes the spring S' to break contact with the lever, and directs the current—which before passed from the lever through the rheostat to line—through the vibrator V to line outside of the rheostat. The point at the vibrator is making and breaking contact with it at the rate of three hundred times per second, making a resistance at that point of about 1,000 ohms. This will vary more or less according as the point is adjusted nearer or further away from the vibrator. When the transmitter opens, the spring breaks with the point, and makes contact with the lever, which directs the current through the rheostat to line. The rheostat has an amount of resistance unplugged equal to the resistance in the vibrator point. It will be seen that this arrangement keeps an even current strength on the line all the time, so that the Morse relays are not disturbed by the writing of the telephone key. The condensers that are around all the Morse relays prevent the vibra-

tions from producing any jar of the Morse armatures. The receiver G at the other end will respond to the electrical vibrations because its armature has a natural rate of vibration coincident with those on the line when the telephone key is closed. The receiving operator reads from an ordinary Morse sounder, and the manner of translating the tone signals as they come on the tuned bar into the ordinary Morse click is as follows: When the sender closes his key the current is thrown in vibration, which causes the sympathetically tuned armature to vibrate. Its vibration causes the secondary lever to jar at the point where it rests on the armature, owing, as before stated, to its inability to follow, its natural rate of vibration being slower than that of the armature. This jar has the effect to open the local circuit. In this circuit is placed a repeating sounder, having a connection on its back point. When its armature falls back it closes a second local, which operates the ordinary reading sounder. The object of this intermediate sounder is to make the down-stroke of the reading sounder correspond with that of the sending-key. The local circuit of the repeating sounder will remain open as long as the vibration continues; and, as it continues just as long as the No. 1 or telephone key remains closed, it follows that the motion of the reading sounder will be an exact copy of the motion of its transmitting-key. It will be seen from the above that the receiving analyzer G is made to perform the work of an ordinary Morse relay.

When either station is sending on the telephone side, at each close of the transmitter the analyzer at the sending-station is cut out by means of the shunting-spring S on the opposite end of the lever from the spring S', so that the sounder at the transmitting end is silent, as the analyzer is cut out at the time the vibrations are sent into the line. If, while one end is sending, the receiving end wishes to signal to the sender to stop for any reason, he depresses his own transmitting-key for a moment. This will send vibrations from the receiving end, and they will be recorded on the sounder of the sender the first time he opens his key, and thereby takes the shunt off his receiving analyzer. At this signal the sender stops to hear what is said.

It will be observed that all this is done without disturbing the equilibrium of the line-current.

Having shown how the telephone signals are sent through the wire without affecting the ordinary relays in the circuit we will now proceed to show how ordinary Morse writing is sent through the same wire at the same time without interfering with the telephonic signals. If, for instance (referring to the diagram), the middle Morse station wishes to communicate with either of the way or end Morse station, he opens his key and calls in the ordinary way.

The opening of any No. 2 or Morse key will not open the line, but merely throw a resistance of 6,000 ohms into it. This resistance is sufficient to cause all the relays to open if they are properly adjusted. The relay springs are of sufficient tension to overcome the residuary charge in the magnets after the resistance is thrown in, and thus hold all the armatures of the Morse relays open. When the resistance is cut out by closing the key, all the armatures are attracted by the increased magnetism. It will be observed that this part of the system does not work by a total make and break, but by the increment and decrement of current strength.

All the Morse keys are kept closed except the one that happens to be sending, and the operation is precisely that of ordinary single-wire-closed circuit Morse. On the other hand, the telephone keys stand open when this part of the system is not working.

If both systems are working at the same time, of course it will happen that a telephone key will be closed when a Morse key will be open; and, if the opening of a Morse key decreases the current strength to such a degree as to furnish a good working margin, why does it not weaken the vibrations correspondingly? The answer is found in the condenser, which shunts the resistance and also the relay when the key is closed.

Whatever theories may be advanced regarding the action of a condenser under such circumstances, the fact still remains that it makes up for the loss sustained by the interposition of the 6,000 ohms resistance, and the vibration margin is nearly, if not quite, as great when the Morse key is open as when closed. And still, as

before stated, the current margin for working the ordinary relay is greatly lowered when a No. 2 key opens.

The vibrations pass through the resistance-coil of the Morse station, where a key is open, and owing to the fact that the condenser now shunts a resistance of 6,000 instead of one or two hundred ohms, as is the case when the key is closed, each vibration charges and discharges the condenser more powerfully, and thus reinforces the vibrations when a Morse key is opened without materially increasing the solid current strength for ordinary Morse signals.

The contrast between having the condenser on or off is very marked, and makes all the difference between success and failure in working this combination system on long lines with a large number of offices. Another important result occurring from the use of the condenser arises from the fact that it prevents the vibrations from being felt upon the Morse relays. Without the condensers they are a source of great annoyance. The action of the condenser here is obvious. When the telephone key is closed, each time the vibrator makes contact with its point it charges the condensers, and each time it breaks the condensers discharge partly through the relays and fill up a gap that would otherwise occur between each vibration.

The advantages of this system over other form of duplex are many, and some of them very great. 1st. The ordinary duplex gives no facilities whatever for way business, and hence its application is limited to through lines, which are few in comparison with the whole number of circuits. This system is applicable to every line, whether way or through. 2nd. In the ordinary duplex messages can be sent simultaneously only in opposite directions.

In the combination system two messages may be sent in the same direction or opposite, as the business demands.

In ordinary duplex, when the receiving operator wishes to "break" the sender, to have him repeat a word, it is necessary to stop the message that is being sent in the opposite direction, and four men are interrupted while this is going on.

In the combination system each receiver can "break" his own sender without the other side taking any notice whatever of the

operation ; so that, other things being equal, more business may be handled by a given number of men in a given time by the combination system. Again, telephone stations may be introduced at way as well as end stations ; in fact, the system may be treated as two independent wires in every respect.

EARTH-CURRENTS.

From numerous observations of earth-currents at the Central Telegraph Station, London, and taking particular notice as regards the various conditions of weather, I have been led to form the following opinion as to their origin :

In the first instance I proved that the currents were not produced by a polarization of the earth-plates, by putting a strong current on the line for some time, and then taking a reading of the earth-current and comparing it with the readings of other wires on the same set of poles, and to the same place: the readings were similar. I now put the same current on the line again but in a reverse direction, for a considerable time, with exactly the same result.

My attention was drawn to the manner in which these currents varied on a cold windy day, with intervals of cloud and sunshine, when it occurred to me that these currents were produced by changes of temperature in the air, and may easily be explained by Faraday's theory of the diurnal variations of the declination magnet.

If we revert to that theory, which has a great amount of probability in it, and go a step further, we have all that is necessary.

Faraday's theory was, that the earth being in all respects a large magnet, the lines of force which proceed from the surface of the northern hemisphere with a certain degree of uniformity pass through the air into space, and there unite over the equatorial regions with other lines of force, which have emanated from the southern hemisphere at a similar inclination but in the opposite direction. Now as the air is composed of a mechanical mixture of oxygen and nitrogen, the former being magnetical and the latter non-magnetical, the oxygen becomes magnetized by the lines of

force and exerts its influence on the declination magnet; but should the air be raised in temperature the oxygen loses a portion of its magnetism, which lessens its effects on the declination magnet on that side which receives the increment of heat, so that in our latitude during the morning hours the atmospheric magnetism will become weakened eastward of us, and cause the declination magnet to point further west. In the afternoon it will, for like reasons, be in the contrary direction, but this change from west to east will not occur at the time the sun passes the meridian on account of the heated mass of air, which will cause the declination magnet to lag for a short period after the sun; this is borne out by the average quiescence of the declination magnet during the night.

Whatever may be the cause of the earth's magnetism we can get the same effect and explain all phenomena by Ampère's theory, and that is, "If we conceive a positive current entering at (what we name) the north magnetic pole, and circulating around the earth in the direction of the hands of a watch, and coming towards the observer until it leaves at the south magnetic pole, the earth will act as a large magnet."

Now, when any conductor passes through magnetic lines of force, if the magnet which propagates these lines of force be moved we have an induced current in the conductor; but if we only partially remove or decrease the power of the magnet we have an induced current in proportion to the amount reduced in the conductor, and so when the solar rays cause a rise in the temperature of the air the magnetism of the oxygen is decreased and thereby produces induced currents in any conductors that are near, but as the temperature of the air is raised gradually from east to west each molecule as it receives its heat will become less magnetic, and so produce an induced current; hence as the molecules get heated in succession we get in consequence a succession of rapid induced currents which show as permanent currents on our telegraph wires. The direction of these currents is determined by the imaginary currents which produce the magnetism of the earth and flow from east to west, so that on the magnetism of the air being decreased by a rise in the temperature the induced currents flow east to west, and when the temperature of the air is again lowered the induced currents flow west

to east, which is equivalent in the first case to a decrease, and in the second to an increase, of magnetism of the earth. May not these induced currents also affect the diurnal variations of the declinometers?

Looking at these currents in this light we have a ready and easy means of accounting for them, especially as they seem to vary in a similar manner to the declination magnets.

We receive under ordinary circumstances positive currents from wires running in a north-easterly direction, and negative from those running in a south-westerly direction, in the morning up to 2 p.m. or 3 p.m., when they commence to change their polarity; those running north-west and south-east give small currents as a rule, and generally of a more unsteady character as to polarity.

There were two other causes which I also thought capable of producing these currents by a change of temperature.

1st. Whether the wire and insulator form a couple, and so produce a thermo-current; but from experiment I could get no signs of a current.

2nd. Whether the wire under the influence of different temperatures would give the currents. I find such currents are produced, but undecided in direction, as a wire with a clean surface gives a current in one direction and a rusty wire in another; moreover, the currents so produced are wanting in electromotive force compared with those which we call "earth-currents"; the latter I reduced from 24 to 5 divisions by means of 32,000^Ω; the former may in all probability have something to do with the homogeneity of the wire.

I attach a reading taken from a wire on the Great Northern Railway to Grimsby, *via* Peterborough and Boston, on Sunday, December 2nd, 1877, when the wind blew with considerable force from the north-east, it being cloudy and sunshine at intervals—

hrs.	m.	s.	hrs.	m.	s.		
12	21	0	20—	12	23	30	10—
	22	0	0		24	0	50—
	22	30	30+		15	0	
	23	0	52+		30	20—	
	15	40—			45	0	

ORIGINAL COMMUNICATIONS.

hrs.	m.	s.	hrs.	m.	s.
12	25	0 · 70—	12	39	30 · 33—
		15 · 75—			45 · 52—
		30 · 40+		40	0 · 58—
		45 · 65+			30 · 40—
	26	0 · 65+		41	0 · 30—
		30 · 60+			30 · 57—
	27	0 · 30+		42	0 · 60—
		15 · 10+			30 · 58—
		30 · 30—		43	0 · 50—
	28	0 · 35—			30 · 34—
		30 · 50—			45 · 30—
	29	0 · 55—		44	0 · 18—
		30 · 45—			15 · 40—
		45 · 20—			30 · 52—
	30	0 · 30—			45 · 49—
		15 · 10—		45	0 · 66—
		30 · 40—			15 · 69—
		45 · 56—			30 · 64—
	31	0 · 57—			45 · 63—
		30 · 60—		46	0 · 63—
	32	0 · 65—			15 · 67—
	33	0 · 60—			30 · 50—
	34	0 · 50—			45 · 7—
		15 · 20—		47	0 · 18—
		30 · 17—			15 · 41—
		45 · 15—			30 · 65—
	35	0 · 21—			45 · 65—
		30 · 30—		48	0 · 65—
	36	0 · 48—			30 · 65—
		15 · 41—		49	0 · 58—
		45 · 47—		50	0 · 55—
	37	0 · 48—			30 · 65—
		30 · 71—		51	0 · 30—
	38	0 · 66—			30 · 28—
	39	0 · 57—		52	0 · 36—
		15 · 40—		53	0 · 50—

hrs.	m.	s.	hrs.	m.	s.
12	54	0 · 50—	1	15	0 · 30+
	55	0 · 54—		16	0 · 31—
	56	0 ·		17	0 · 28—
	57	0 ·		18	0 · 27—
	58	0 · 40+		19	0 · 1—
	59	0 · 42—		20	0 · 12+
1	0	0 · 53—		21	0 · 10—
	1	0 · 5+		22	0 · 32—
	2	0 · 14+		23	0 · 4+
	3	0 · 21+		24	0 · 35+
	4	0 · 13+		25	0 · 37+
	5	0 · 25+		26	0 · 5+
	6	0 · 7+		27	0 · 8—
	7	0 · 12—		28	0 · 42+
	8	0 · 15+		29	0 · 37+
	9	0 · 27+		30	0 · 40+
	10	0 · 15+		31	0 · 11—
	11	0 · 12—		32	0 · 23+
	12	0 · 29—		33	0 · 15—
	13	0 · 3—		34	0 · 32—
	14	0 · 28—		35	0 · 2+

The Boston circuit on the same railway was affected in a similar manner. There were no other wires working on this line at the time the readings were taken.

I would suggest that these currents were produced in the North Sea by the varying temperature and pressure of the air, and, flowing in a direction at right angles to the magnetic meridian, met the earth-plate of the Grimsby circuit, and so reached London; the soil round Grimsby, being marshy and damp, would form a better conductor than is usually found on the coast, and hence the incessant variations.

All wires were very much disturbed on the day in question up to 3 p.m., when they became much steadier.

At 4 p.m. I found all wires from the Eastern Counties were giving off minus currents, and on trying the wires on the South Western Railway could get no currents on wires between London and Exeter, *but those which extended beyond Exeter still gave off*

minus currents; in another half-hour the South Western Railway wires commenced to give off positive currents.

Out of six wires which went to Brighton, three were extended to Lewes, Arundel, and Worthing for local work. I could get no currents from any of them between 10 a.m. and 4 p.m., with one exception, and that was the wire which went to Lewes, and gave a steady current of -55 ; at this time the current began to decrease rapidly, and soon became one of a positive character, whilst the other wires were still quiet.

S. M. BANKER.

12th December, 1877.

[The following interesting observation was made at Bristol on March 16th, 1877:—

At 8·10 p.m. a deflection of 22° in the negative direction was observed on the Bristol cam circuit, gradually decreasing in strength and disappearing altogether at 8·20. At the same time the Bristol-Reading wire was observed to be similarly affected, the deflection at 8·14 p.m. being 30° , at 8·20 20° , at 8·22 10° , and finally clear at 8·25, negative direction. No other circuit was noticed to be affected. The weather at 7·25 p.m. was very fine; at 8 p.m. a smart storm of sleet was experienced; the atmosphere becoming again clear and starry at 8·20. Constant through $1,000^\omega$ with one cell Daniell's (chamber form) 9° .

This indicates clearly that the storm of sleet was accompanied by atmospheric electrical disturbance, and that positive electricity was discharged into the earth at Bristol through these two circuits, which therefore acted as lightning conductors.—W.H.P.]

EMPLOYMENT OF OLD RAILWAY METALS FOR TELEGRAPH POLES.

The following extract from a letter from Mr. G. B. Davids, of the Paulista Railway, Brazil, is furnished by the Acting Secretary:—

“Up to the present we have used wooden poles of the very worst and crooked description. These will not last for more than two years in safe condition, or at the outside three years, thus costing *the Company* over £2,500 every three years for renewals. We

PLATE I.

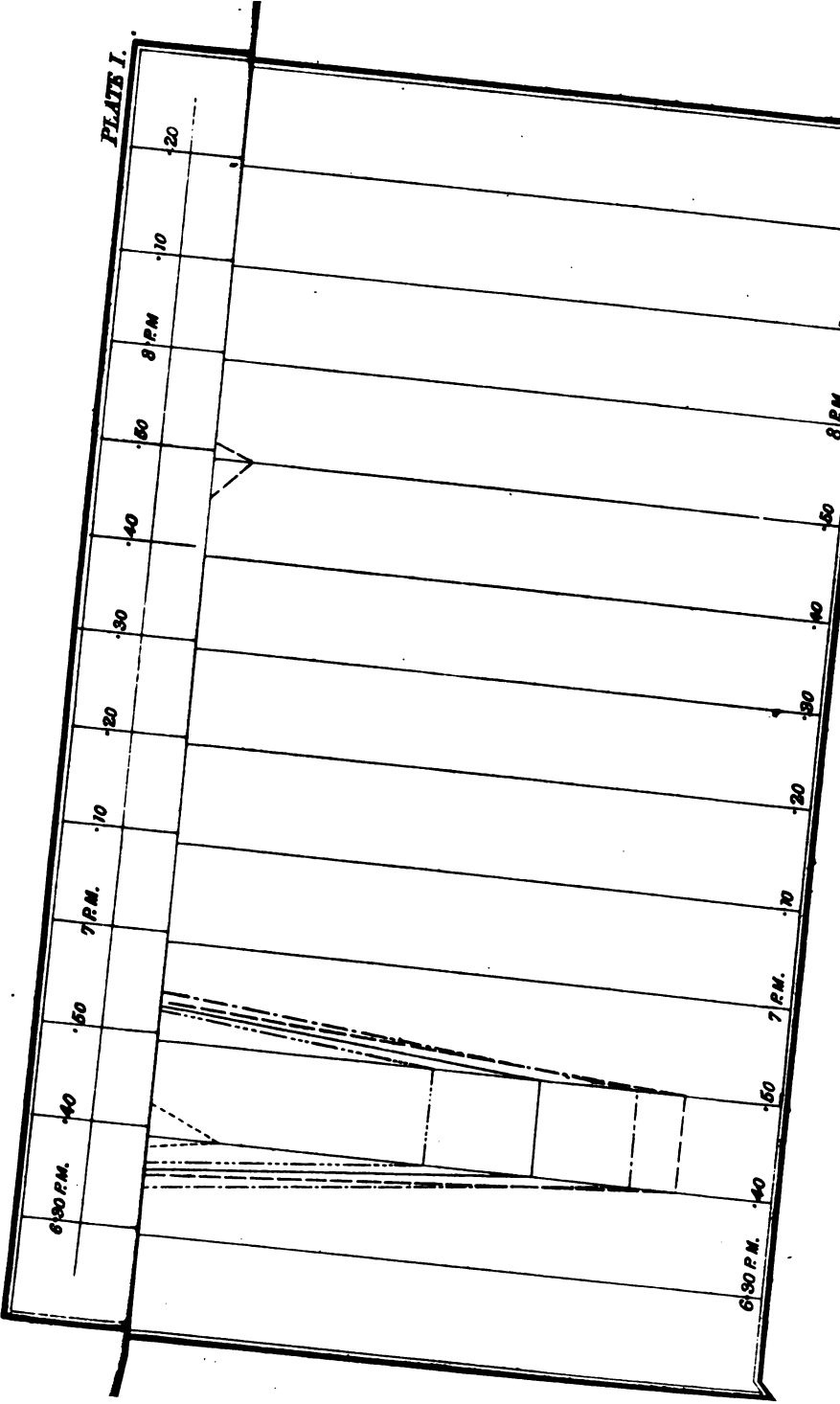

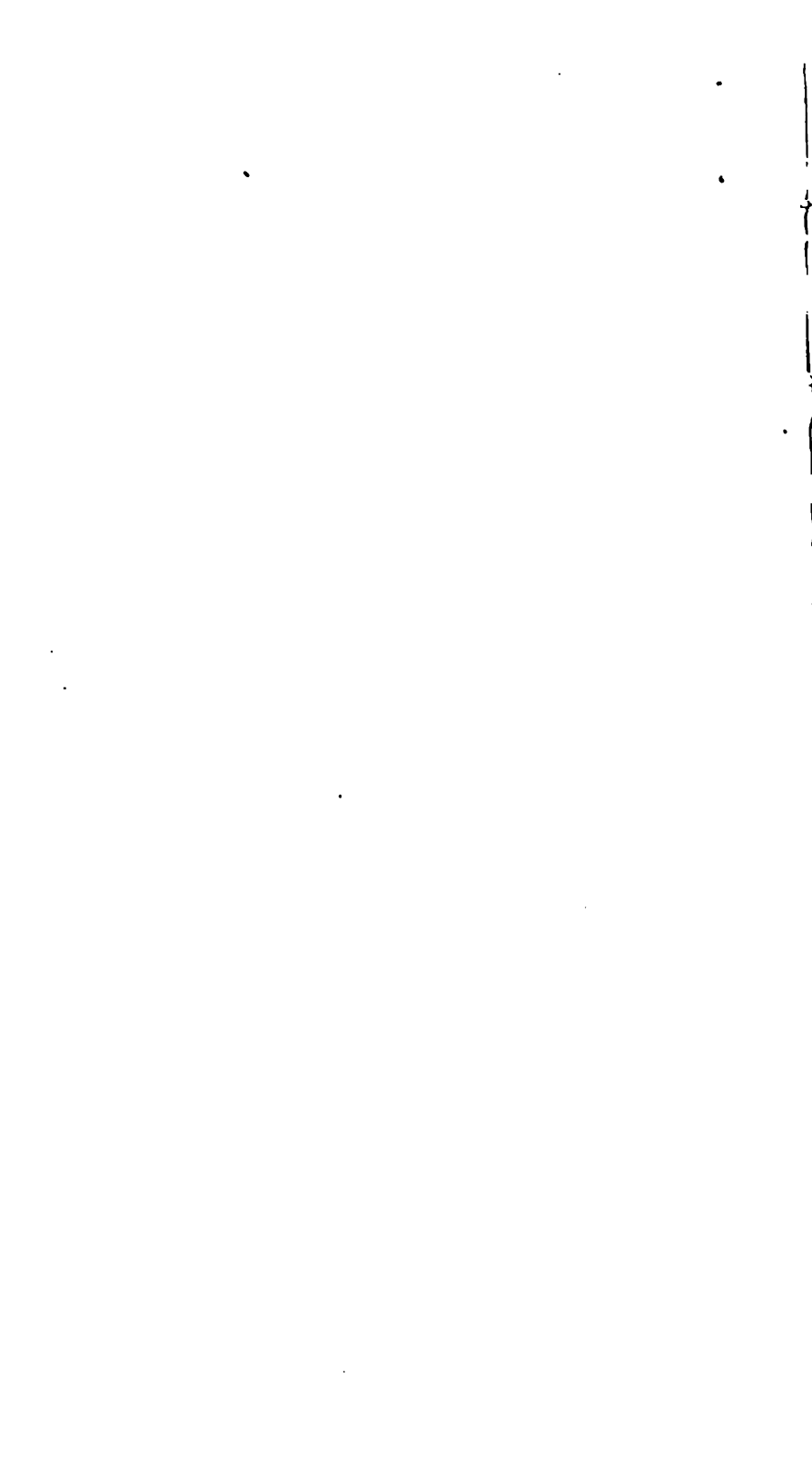

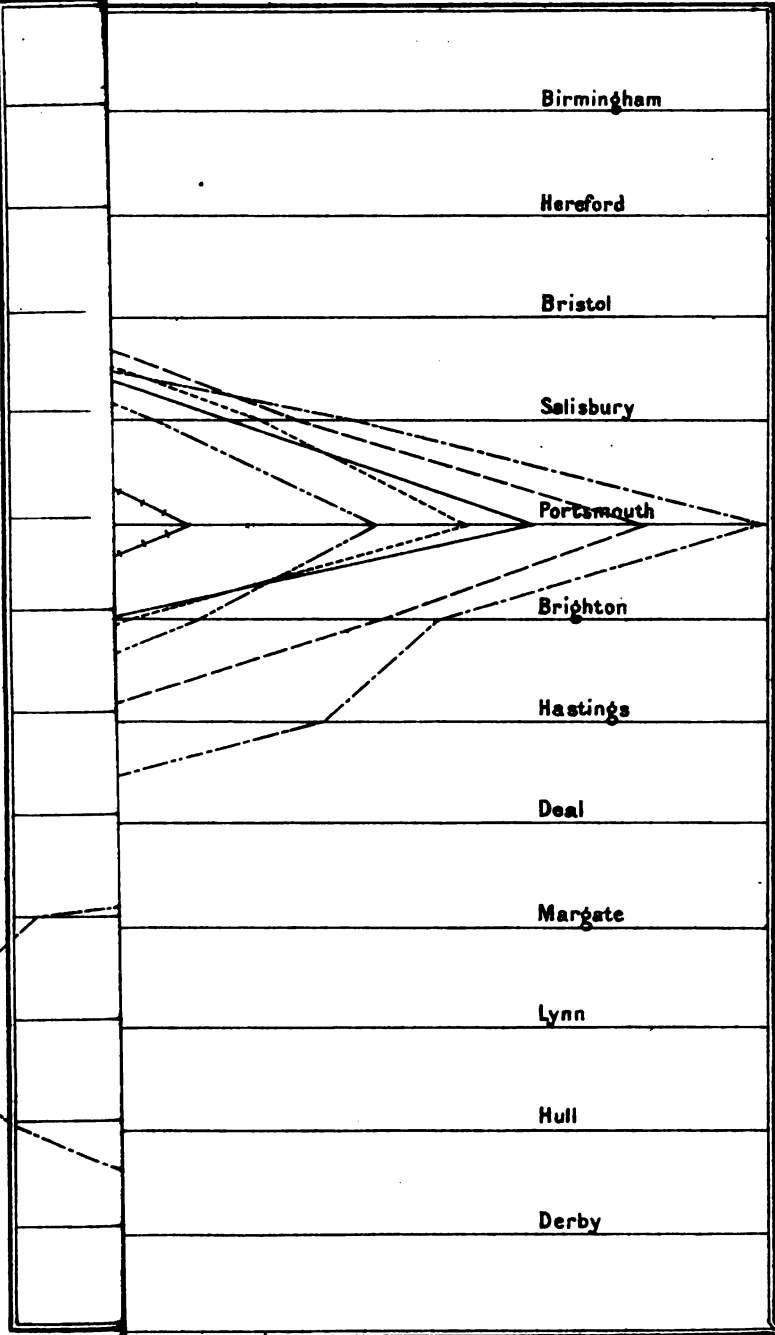



Nottingham

Liverpool

Hereford

Bristol

Southampton

Hastings

Deal

Margate

Colchester

Boston

Doncaster

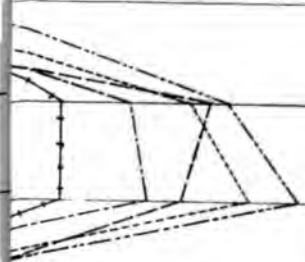



25-26 June 1876.

12:30 P.M.
12 P.M.

Nottingham

Liverpool

Shrewsbury

Bristol

Southampton

Brighton

Hastings

Margate

Lynn

Grimsby

Sheffield

12 P.M.

12:30 P.M.

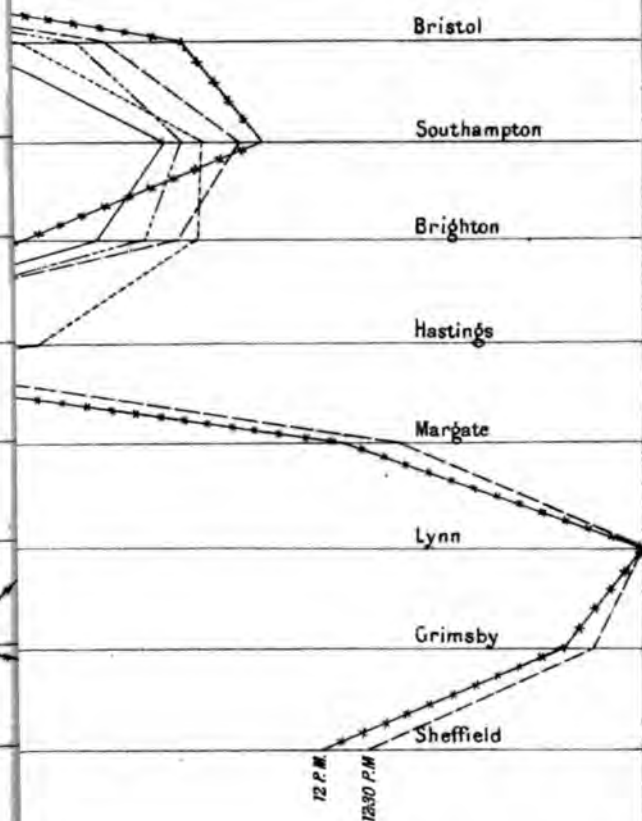
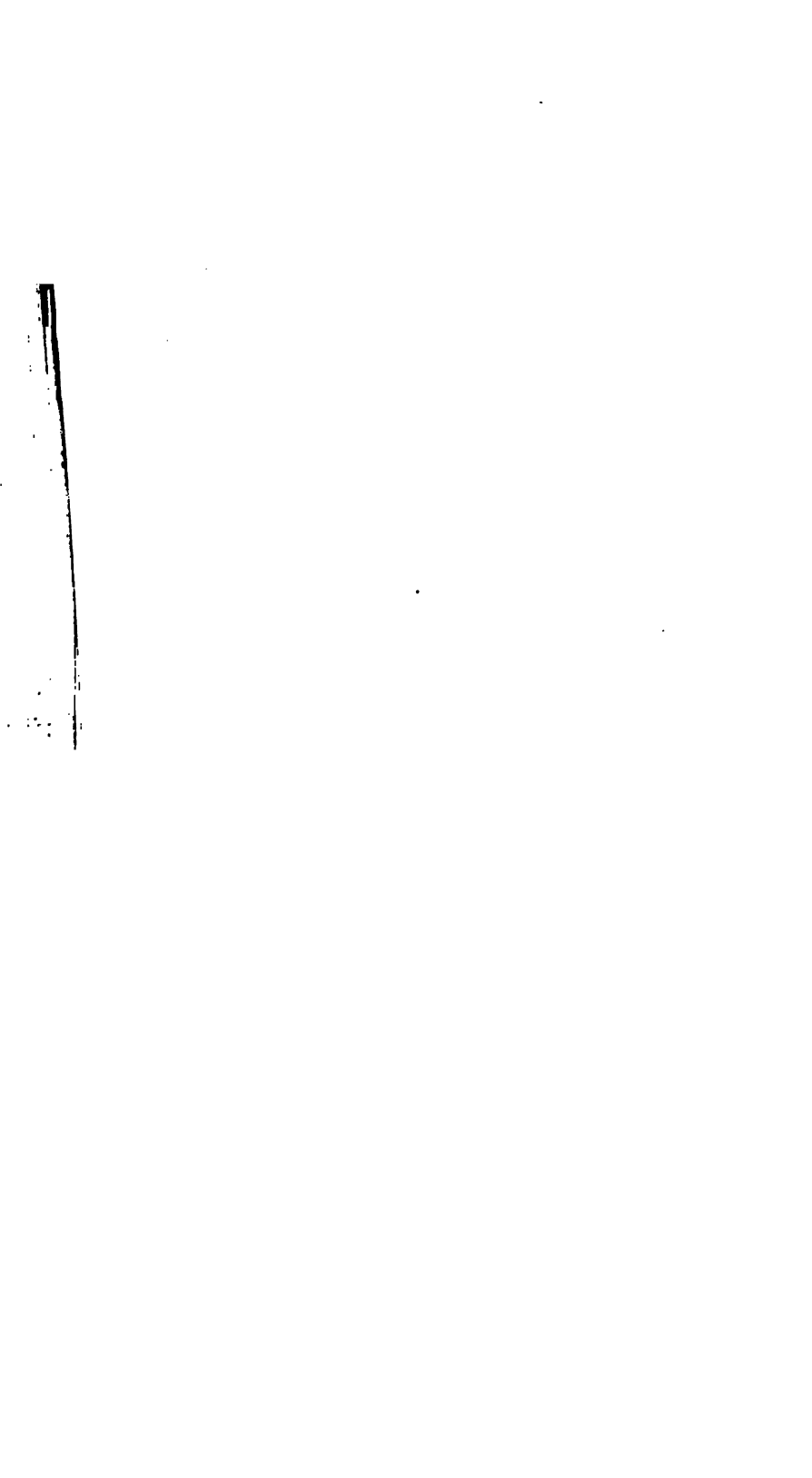



PLATE V.

	Sheffield
	Liverpool
	Shrewsbury
	Bristol
	Southampton
	Hastings
	Deal
	Margate
	Colchester
	Yarmouth





hundreds of old rails lying about which are absolutely worthless as no one will buy them here and it does not pay to send them here. These I am now using for poles. They make a beautiful pole, perfectly straight, all the same height, and I will warrant will never rot. They do not cost as much as new poles of wood, and take very little longer to erect. I have them brought into the

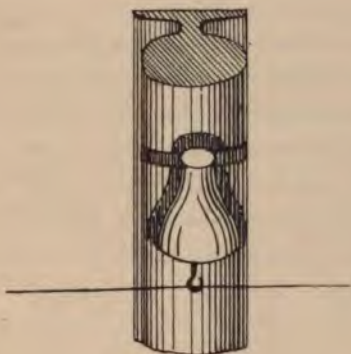

shops, and holes drilled $\frac{3}{4}$ inch deep on the round (top) side, one foot from the top, and 16 inches apart; into these are driven iron pegs $1\frac{1}{2}$ inch long. The insulators (Siemens No. 1, iron-hooded) are sat on the top of these pegs and then a wrought-iron band is driven over the plate of the insulator (which was formerly screwed to the wooden poles), at the same time clipping the rail. It makes a perfect fastening very easily fixed. In the case of an insulator being broken, nothing is more simple than to hit up the band, sit a new insulator on the peg, and drive the band over again.

"I have now seven kilometres renewed with these rails, and they make a beautiful line, such a contrast to the old lines, with the poles set at all sorts of angles, without any regard to straight lines. I should say that the rails are put six feet into the ground and well punned. I have a hole drilled ($\frac{3}{4}$ inch diameter) in the side of the rail one foot below the bottom insulator; to this the stay wire is attached. I use "signal" strand wire for stays, and for stay blocks short pieces of old rail from 3 feet to any length. U & G

round holes about 2 feet in diameter. They are first opened with a tool called here a *canadeira*. This has a handle about 6 feet long. The broken earth is taken out with a spade at first, and, when the hole gets too deep, by a tool I had made, something like a spade with sides to it, bent up to a smaller angle than a right angle; this has a handle about 10 feet long, which the men use by pressing against their shoulders and lifting. I timed two men making a 6-foot hole with these tools, and it took them a little over 30 minutes.

“For erecting the poles I employ two pinewood shearlegs, bolted together at the top, so that in moving from hole to hole they can be shut up. These are supported by a strong rope fastened to the top of the poles and tied to any available object. On the opposite side of this rope is another small rope, which is fastened to an iron bar driven in the side of the bank, merely for the purpose of steadying the legs and preventing them from springing back after each pull at the blocks. It answers admirably.”

A NEW WIRE-FINDER.

The accompanying figure illustrates a simple and useful wire-finder.

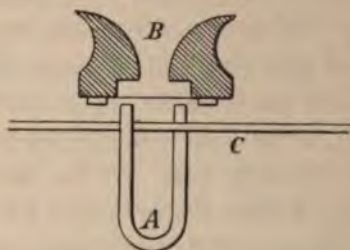

A, a horse-shoe magnet, may be of steel wire.

B is the section of a light wooden cylinder, on the under side of which is fixed a round plate of thin iron, such as is used for photographs.

C, the wire to be tested, is held between the poles of the magnet, and touching it. The ear is placed at B.

One pole of the magnet may rest on the plate and the other be approached as near as possible.

Signals passing through the wire can be easily distinguished. It matters not if the wire be covered with gutta-percha, or if it be an ordinary iron line-wire.

For trench-work it is desirable to send intermittent currents from a pendulum or other means.

The instrument is wonderfully sensitive, and Morse signals can easily be read.

It was suggested to me some time ago on finding how a comparatively weak current sent through the magnet itself could be distinguished on a plate arranged as above.

Here I cannot refrain from calling attention to Mr. Bell's telephone, which, in its latest form, is very convenient.

At cable stations they may be found very useful. They will indicate the presence of currents which are not visible on a mirror galvanometer, and enable us to trace small disturbances, through earth connections and inductive action between wires, to their source.

The observance of earth-currents by their aid is extremely interesting, and one placed in circuit with a short line will foretell unmistakably a lightning storm.

The island of St. Pierre is perhaps better insulated than most places—hundreds of yards from the station, if a wire be connected to earth and run some distance to earth again, and a telephone be placed in its circuit, the signals passing through the cables may be heard. I may add that mirror signals cannot be read on it.

The possibility of speaking through considerable distances of earth without wires is certainly possible with Bell's telephone, with a battery and Morse signals. It is the most sensitive of sound-instruments, and will, as I have said, indicate currents to which the mirror does not respond.

On a spare subterranean wire between this station and the sea (two miles), there is on the telephone a continuous loud roaring sound with hissing discharges, varying in intensity from day to day and from hour to hour—during Aurora the commotion is tremendous. The louder discharges corresponding with "kicks" on the speaking galvanometer of the Brest cable.

J. GOTT.

ABSTRACTS AND EXTRACTS.

ON THE GENERAL THEORY OF DUPLEX TELEGRAPHY

By LOUIS SCHWENDLER.

Paper read before the Asiatic Society of Bengal.

(Continued from p. 377.)

In the two preceding investigations I have given the solution of the first problem for the bridge method. This solution established the general result of the double balance being the best possible arrangement for the bridge method. In the present paper I shall endeavour to find the solution of the first problem for the differential method, which in practical importance ranges second to the bridge method.

II. *Differential Method.**

This arrangement for duplex working is based on the well-known method of comparing electrical resistances—"differential method;" and the following figure gives the general diagram when this method is applied for duplex working.

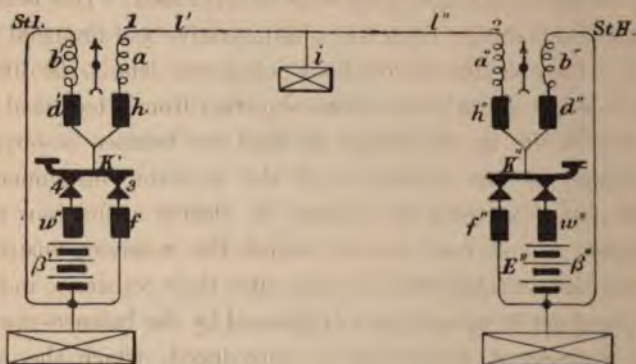

E , electromotive force of the signalling battery
 β , internal resistance of the signalling battery.

* The differential method was originally invented, as stated before, by Mr. Frisén and by Messrs. Siemens and Halske. A particular case of this method was patented by them in England in 1854.

k , a constant resistance-key.

a and b , the coils of the receiving-instrument. These coils, for any sent current, have opposite magnetic effects with respect to any given magnetic pole external to the coils, while for any received current these coils add their effects with respect to that same magnetic pole. By a and b shall also be designated the resistances of the coils.

d , w , f , and h are certain resistances, the necessity of which will become clear hereafter.

i , the resistance of the resultant fault of the line, acting at a distance l' from station I., and at a distance l'' from station II. (both l' and l'' expressed in resistances, so that $l' + l'' = L$ equal the "real conduction-resistance" of the line).

The other terms, viz. L' , L'' , ρ' , ρ'' , c' , c'' , &c., which will necessarily be of frequent occurrence also in this paper, will bear the same physical meaning as before.

The practical inferiority of the differential method, when compared with the bridge method, it will be clear at once, is that specially constructed receiving-instruments on the differential principle are required, and that therefore the introduction of duplex telegraphy based on the differential method would at once involve also a total change on the receiving-instruments hitherto used. This is clearly a serious disadvantage from an administrative and financial point of view. But, besides this, without going into details, the differential method has also a very serious objection from a technical point of view. While in the bridge method the balance is obviously independent of the resistance of the receiving-instrument, in the differential method the balance is clearly a function of the resistances of the two coils of which the receiving-instrument consists; and as these two coils may alter their resistance independently, and not in proportion as indicated by the balance-equation, a new element of disturbance is introduced, which the bridge method certainly does not possess.

Besides this, differential instruments are necessarily mechanically more complicated than others, and require therefore superior workmanship, entailing greater expense to arrive at working efficiency.

General expressions for the two functions "D" and "S."

In order to obtain the two functions D and S we have to develop the general expressions for p , P, and Q, say for station I.

p' in our particular case is the force exerted by the two coils a' and b' on one and the same magnetic pole when station I. is sending and station II. is at rest. This force is clearly the difference of the two forces exerted by the coils a' and b' .

Thus we have

$$p' = A' m' - B' n',$$

where A' and B' are the currents which pass through the two coils a' and b' respectively when station I. is sending and station II. is at rest, while m' and n' are the forces exerted by these coils when the unit current passes through them. At balance in station I.

$$p' = 0.$$

Further,

$$P' = \mathfrak{A}' m' + \mathfrak{B}' n',$$

where \mathfrak{A}' and \mathfrak{B}' are the currents which pass through the coils a' and b' respectively when station II. is sending and station I. is at rest (single signals).

Further,

$$Q' = \mathfrak{V}' m' + \mathfrak{Q}' n',$$

where \mathfrak{V}' and \mathfrak{Q}' are the currents which pass through a' and b' respectively when both stations are sending simultaneously (duplex signals).

To get the most general expressions for these three forces, p , P, and Q, we have to fix the signs of the two terms of which they consist. This is best done by considering the forces m and n as absolute numbers, and determining the direction in which they act with respect to one and the same magnetic pole by the direction of the currents passing through the coils a and b .

To fix the signs of the currents, we shall call, arbitrarily, that current positive which passes through the coil a in the sending-station when the negative pole of the signalling-battery is joined to earth.

Further, if we suppose at the outset that the movement of the key k does not alter the complex resistance ρ of its own station, *i.e.* the fulfilment of the key-equation

$$w + \beta = f,$$

a condition which is essential, it is clear that the currents \mathbb{V}' and \mathbb{G}' are the algebraical sums of the currents A' , \mathfrak{A}' and B' , \mathfrak{B}' respectively; whence it follows that

$$Q' = (A' + \mathfrak{A}')m' + (B' + \mathfrak{B}')n',$$

where the currents contain the signs.

Now, with respect to the manner of connecting up the two signalling-batteries E' and E'' , we have the following two different cases:—

1st. The same pole of the signalling-battery is connected to earth in each station, thus:

$$\begin{aligned} p' &= \pm A'm' \mp B'n', \\ P' &= \mp \mathfrak{A}'m' \mp \mathfrak{B}'n', \\ Q' &= (\pm A' \mp \mathfrak{A}')m' + (\mp B' \mp \mathfrak{B}')n', \end{aligned}$$

where the upper signs are to be used when the negative poles of the signalling-batteries are connected to earth in both stations, and the lower signs when the positive poles of the signalling-batteries are connected to earth in both stations.

2ndly. Opposite poles of the signalling-batteries are connected to earth in the two stations, thus:

$$\begin{aligned} p' &= \pm A'm' \mp B'n', \\ P' &= \pm \mathfrak{A}'m' \pm \mathfrak{B}'n', \\ Q' &= (\pm A' \pm \mathfrak{A}')m' + (\mp B' \pm \mathfrak{B}')n', \end{aligned}$$

where the upper signs are to be used when the negative pole in station I. and the positive pole in station II. are connected to earth, and the lower signs when the reverse is the case.

Subtracting in either of these two cases Q' from P' , it will be seen that invariably

$$S' = Q' - P' = p';$$

or that, on account of having fulfilled the key-equation $w + \beta = f$, the difference of force by which signal and duplex signals are produced is equal in magnitude and sign to the force by which

balance is disturbed; further, that it is perfectly immaterial whether the same or opposite poles of the signalling-batteries are put to earth. For reasons already explained, I prefer to use the negative poles of the signalling-batteries to earth in both stations; and this alternative we will suppose is adopted.

Thus we have

$$\begin{aligned} p' &= A'm' - B'n', \\ P' &= -(\mathfrak{A}'m' + \mathfrak{B}'u') \\ Q' &= (A' - \mathfrak{A}')m' - (B' + \mathfrak{B}')n'. \end{aligned}$$

If we now substitute for A' , B' , \mathfrak{A}' , \mathfrak{B}' their values, we get

$$\begin{aligned} p' &= \frac{E'}{N'} \Delta', \\ P' &= -\frac{E''(b'' + d'')}{N''} \mu' \lambda' \end{aligned}$$

and

$$Q' = -\frac{E''(b'' + d'')}{N''} \mu' \lambda' + \frac{E'}{N'} \Delta',$$

the sign of p' being contained in Δ' , and where

$$\begin{aligned} N' &= f'(b' + d' + a' + h' + c') + (b' + d')(a' + h' + c'), \\ N'' &= f''(b'' + d'' + a'' + h'' + c'') + (b'' + d'')(a'' + h'' + c''), \end{aligned}$$

$$\mu' = i + \frac{i}{l' + \rho'},$$

$$\Delta' = (b' + d')m' - (a' + h' + c')n',$$

$$\lambda' = m' + \frac{f'}{b' + d' + f'} n'.$$

Thus the general expressions for the two functions D and S are

$$\left. \begin{aligned} D' &= \frac{p'}{P'} = \frac{E'}{E''} \cdot \frac{N''}{N'(b'' + d'')} \cdot \frac{\Delta'}{\mu' \lambda'}, \\ S' &= p' = \frac{E'}{N'} \Delta', \end{aligned} \right\} \text{for station I,}$$

and

$$\left. \begin{aligned} D'' &= \frac{p''}{P''} = \frac{E''}{E'} \cdot \frac{N'}{N''(b' + d')} \cdot \frac{\Delta''}{\mu'' \lambda''}, \\ S'' &= p'' = \frac{E''}{N''} \Delta'', \end{aligned} \right\} \text{for station II.}$$

Rigid fulfilment of the two functions $D=0$ and $S=0$.

D can only become zero for finite resistances of the branches if

$$p = S = 0,$$

i.e., if

$$\Delta = 0.$$

Now, to keep $\Delta = 0$, we may adopt two essentially different modes of readjustment, namely:—

Either leave the two coils and their armatures stationary, and adjust balance by altering the resistance of the branches ($a + h$) and ($b + d$) separately or simultaneously, or leave the resistances of these branches constant and move the coils or their armatures. These two cases are to be considered separately.

(a) *Readjustment of balance by altering the resistance of the branches.*

As a and b are resistances which in the form of coils have to exert magnetic force, it is impracticable to suppose them variable. If they have been once selected, they must necessarily be kept constant, whence it follows that the readjustment of balance is restricted to a variation of one or both of the resistances h and d .

But as ρ is a function of h and d , to establish balance by altering one of them only would invariably result in an alteration of ρ , and consequently immediate balance would become an impossibility.

Thus in order to readjust balance, and at the same time to keep ρ constant,* we must vary h and d simultaneously.

Now it can be proved, in exactly the same manner for the differential method as was done for the bridge, that in order to make the disturbance of balance for any given variation in the system as

$$\rho = a + h + \frac{(b + d)f}{b + d + f};$$

keep a , b , and f constant, and vary h and d ; whence we should have

$$\partial\rho = (b + d + f)(b + d + f + \partial d) \partial h + f^2 \partial d = 0,$$

an equation which it is always possible to fulfil for any variations of h and d if taken of opposite signs, although it may be difficult to achieve it practically by a simple motion, such as that of turning a handle. The absolute value of these variations depends, of course, on the variation of c which disturbs the balance; and in order to have accelerated balance we ought to decrease h and increase d when c increases, and *vice versa*.

small as possible we must make ρ as large as possible, whence it follows from the form of ρ that

$$f = b + d,$$

the "regularity condition" for the differential method.

But since

$$f = w + \beta,$$

it follows that to re-establish balance by an alteration of the resistances h and d while a , b , β , and ρ keep constant, we have to vary all the four branches h , d , w , and f simultaneously in such a manner that their variations fulfil the following condition,

$$\delta f = \delta d = \delta w = -(2\delta h),$$

which is simple enough to allow of its practical application, but which nevertheless shows again the inferiority of the differential method as compared with the double balance; *i.e.*, in order to fulfil immediate balance, the key-equation, and the regularity condition for the differential method, we have to make the four branches of the system simultaneously variable, while in the double balance the same effect can be obtained by having only one branch variable (the b branch).

It is worth while to mention here that there is a special case of obtaining immediate balance for the differential method by the adjustment in one branch, namely, when $f = 0$; for then ρ would be independent of d , and therefore balance could be obtained by varying d without altering ρ .

However, on account of the key-equation $f = w + \beta$, it would follow from $f = 0$ that β must be zero also; which represents a physical impossibility, inasmuch as the internal resistance of galvanic cells cannot be reduced to zero, not even approximately. Besides, the electromotive force requisite for duplex working being necessarily comparatively large, β will always be a quantity which cannot be neglected against the other resistances of the system, even if the single cells were of small resistance.

But, supposing it were practicable to construct a battery of exceedingly low internal resistance, then, as $f = b + d$, it would be necessary to make $b = 0$ and $d = 0$, another physical impossibility,

as b must consist of convolutions to produce magnetism, and d must be variable to produce balance.

This solution $f = b + d = w + \beta = 0$, or even each of these three branches of an only exceedingly small resistance, must therefore be rejected.

(b) *Adjustment of balance by moving the coils or armatures.*

This, it will be clear, is the solution for immediate balance; for such a mode of adjustment would involve no relation between the resistance of the three branches, leaving their determination free for other purposes. In order that the slightest movement of the two coils or their armatures may produce the required balance it will be best to move both the coils or armatures simultaneously in the same direction. In fact, to be able to produce balance, no matter how great the variation in the resistance of the line may become, it will be necessary to make the coils movable for the changes of seasons, and the armatures for the daily changes.

It is clear that the differential method, when balance is adjusted by the movement of the coils or armatures, can alone be compared in efficiency with the double balance; and the superiority of the latter is most striking. While immediate balance and the fulfilment of the other two essential conditions can be obtained with the double balance method within any given range by a variation of the resistance in one single branch (b branch), this same result with the differential method can only be arrived at by either supposing four branches simultaneously variable, or by supposing the coils and armatures movable — both presupposing complicated mechanical arrangements requiring delicate workmanship and being liable to get out of order.

Rapid approximation of the two functions D and S towards zero.

Supposing the fulfilment of the key-equation as one of the most essential conditions, we know that

$$p = S \text{ for each station invariably.}$$

Now for station I. we have

$$p' = S' = E' \frac{\Delta'}{N'},$$

where

$$\Delta' = (b' + d')m' - (a' + h' + c')n',$$

$$N' = f'(b' + d' + a' + h' + c') + (b' + d')(a' + h' + c').$$

If we call c' that value of the measured circuit which for any given values of the two branches $b' + d'$ and $a' + h'$ produces balance in station I. (*i.e.* for which $\Delta' = 0$), then, if c' varies with $\delta c'$, we have $\Delta' = n'\delta c'$, while N' becomes $N' + \delta N'$.

Thus we have

$$S' = E' \frac{n'\delta c'}{N' + \delta N'},$$

$$S' = \frac{E'n'}{f' + b' + d'} \cdot \frac{\delta c'}{a' + h' + \frac{f'(b' + d')}{f' + b' + d'} + c' + \delta c'};$$

but as $a' + h' + \frac{f'(b' + d')}{f' + b' + d'} = \rho'$ the complex resistance in station I., and as further $\delta c'$ can be neglected against c' , we have finally

$$S = E' \frac{n'}{f' + b' + d'} \cdot \frac{\delta c'}{c' + \rho'}.$$

Further, n' , the force exerted by the coil b' on a given magnetic pole when the unit current passes through the coil, can be expressed as follows:—

$$n' = r' \sqrt{b'};*$$

where r' is a coefficient depending only on the dimensions and shape of the coil, on the manner of coiling the wire, and on the integral distance of the coil from the magnetic pole acted upon.

Thus we have

$$S' = E' \frac{r' \sqrt{b'}}{b' + f' + d'} \cdot \frac{\delta c'}{c' + \rho'} = E' \cdot W' \cdot \theta'.$$

Now, supposing the factor W' constant,† S' becomes smaller the smaller θ' is.

* This expression supposes that the thickness of the insulating covering of the wire can be neglected against the diameter of the wire, which is allowable. r' is a constant with respect to b' .

† That W' can be kept constant while θ' decreases and $\frac{f'}{b' + d'}$ varies and $f' + b' + d'$ is constant, it will be clear is possible; for if $d' > 0$, the variation of $b' + d'$ may be considered entirely due to a variation of d' equal and opposite in sign to the variation of f' . If $d' = 0$, then we must consider r' variable with b' in order to keep W' constant while $\frac{f'}{b'}$ varies, which is admissible, since the position of the coils has not been fixed.

In the second part it has been proved quite generally that θ decreases permanently with increasing ρ' and ρ'' , no matter to what special cause the variation of c' is due, whence again it follows that ρ should be a maximum.

From the form of ρ , however, we see that for any given sum $b + f + d$, ρ becomes largest if

$$f = b + d,$$

which is "the *regularity condition*" of the differential method.

To have S, therefore, for any variation as small as possible, we must make $f = b + d$. Substituting this value of f , we get an expression for S which shows that it has an absolute maximum for b , but no minimum, from which we conclude that b should be made either very much smaller or very much larger than the value which corresponds to a maximum of S; but no fixed relation between b and d or a can be found.

In order to prove that $b + d = f$ is *the solution*, we must show how that it also makes D as small as possible.

But as

$$D = \frac{S}{P}$$

we have only to show that the regularity condition $b + d = f$ makes P either as large as possible, or, which would be still better, a maximum.

Now $P' = A'' \mu' \lambda'$,

where A'' is the current which enters the line at point 2 (fig. 2) when station II. is sending alone, while μ' is the factor which determines the loss through leakage of the line, and λ' is the factor to which the magnetic force exerted by the current $A'' \mu'$ in station I. is proportional.

μ' and λ' are functions of the resistances in station I. only,* but not of those in station II.

Now, for constant values of μ' and λ' (*i.e.* leaving everything in station I. constant), P' becomes larger the larger A'' is.

$$A'' = E'' \frac{b'' + d''}{N''}.$$

* $\mu' = \frac{i}{i + l' + \rho'}$; $\lambda' = m' + \frac{f'}{f' + b' + d' n'}$.

Substituting its value for N' , and dividing numerator and denominator by $b'' + d''$, we get

$$A'' = \frac{E''}{f'' + \frac{f''(a'' + h'')}{b'' + d''} + a'' + h'' + c'' \left(1 + \frac{f''}{b'' + d''}\right)}.$$

Supposing balance in station II. rigidly fulfilled, we have

$$(b'' + d'') m'' - (a'' + h'' + c'') n'' = 0;$$

$$\therefore c'' = (b'' + d'') \frac{m''}{n''} - (a'' + h'').$$

Substituting this value of c'' in the expression for A'' and reducing, we get

$$A'' = \frac{E'' r'' \sqrt{b''}}{f'' r'' \sqrt{b''} + q'' (b'' + d'' + f'') \sqrt{a''}}.$$

Dividing by q'' and putting $\frac{r''}{q''} = v''$, we have

$$A'' = E'' \frac{v'' \sqrt{b''}}{f'' v'' \sqrt{b''} + (b'' + d'' + f'') \sqrt{a''}}.$$

This expression has a maximum* for

$$b' = f' + d',$$

which contradicts the regularity-condition $f' = b' + d'$ so long as d' is different from zero.

Thus, in order to fulfil the regularity-condition and the maximum current for the differential method simultaneously, we must put

$$d = 0.$$

However, it has been shown that, in order to have immediate balance, when adjusting balance by a variation in the resistances, we have to alter the resistances of the four branches $b + d$, $a + h$, f , and $w + \beta$ simultaneously according to a relation already given. Thus it is proved that adjustment of balance by an alteration of the resistances must be rejected, since, as pointed out before, a variation of the resistances of the coil b is impracticable.

We are obliged therefore to adjust balance by moving the coils,

* In order to keep the balance in station II. rigid when b'' varies, we must suppose v'' simultaneously variable with b'' . This is perfectly justified; for v'' can be altered by an appropriate movement of the coils to keep up the balance in station II. without altering the outgoing current A'' .

or their armatures; and the further solution of the problem is only required when this mode of adjustment is adopted.

Maximum Magnetic Moment.

It has now been proved that d is to be made zero, in order to be able to fulfil the conditions of *regularity* and *maximum current* simultaneously, and that therefore, to obtain immediate balance, readjustment of balance is to be effected by a movement of the two coils a and b or their armatures, and *not*, as has been generally proposed, by an alteration of the resistance in the branches ($a + h$ and $b + d$).

Hence h appearing in the denominator of P only, and $h > 0$ not being any more required for adjusting balance, the best value we can give to h is

$$h = 0,$$

which will make P obviously largest.*

Substituting therefore in the expression for P

$$\begin{aligned} h &= d = 0, \\ f &= w + \beta = b, \end{aligned}$$

we get

$$P' = \frac{E''}{2(a'' + c'') + b''} \mu' \lambda' \text{ for station I.}$$

and

$$P'' = \frac{E'}{2(a' + c') + b'} \mu'' \lambda'' \text{ for station II.}$$

These two expressions do not as yet contain the balance-conditions.

The factors $\frac{\mu'}{2(a'' + c'') + b''}$ and $\frac{\mu''}{2(a' + c') + b'}$

are identical, namely

$$\frac{\mu'}{2(a'' + c'') + b''} = \frac{\mu''}{2(a' + c') + b'} = \frac{i}{Q},$$

* The resistances d and h , without exerting magnetic force, were originally introduced in order to investigate the possibility of adjusting balance by an alteration of the resistances in the branches. But, since it has been shown that this mode of adjustment is to be rejected, it is of course clear that the dead resistances in these branches should be made zero, when P will become largest.

where

$$Q = i\{2(a' + a'' + l' + l'') + b' + b''\} + \frac{b'l''}{2} \\ + (a'' + l'')(a' + l' + b') + (a' + l')(a'' + l'' + b''),$$

as can be easily calculated by substituting for λ , a , and c their known values.

In the second investigation it has been stated why P' and P'' cannot be made maxima separately, and that we could do nothing else but make their sum a maximum. In this case we have to do the same. Hence the question to be solved is reduced to the following:

$$P = P' + P'' = i \cdot \frac{E''\lambda' + E'\lambda''}{Q}$$

is to be made a maximum with respect to the variables a , b , q , and r , while they are linked together by two condition-equations, namely

$$r'(a' + c') - q' \sqrt{a'b'} = 0 \text{ balance in station I,}$$

$$\text{and } r''(a'' + c'') - q'' \sqrt{a''b''} = 0 \quad ,, \quad ,, \quad \text{II.}$$

This general problem can be solved in exactly the same way as it was in the second investigation. However, it is not needed to do this again, since the general solution can be written down from inference, after having solved the special problem for a line which is perfect in insulation.

Suppose that $i = \alpha$, or at least very large as compared with $l' + l'' = L$, then obviously P' and P'' become identical without condition; namely,

$$P' = P'' = P = \frac{E}{4} \frac{2q\sqrt{a} + r\sqrt{b}}{L + 2a + b};$$

while the two balance-equations become also identical, namely

$$2q\sqrt{ab} - r(4a + b + 2L) = 0.$$

If we substitute the value of r from the balance-equation in the expression for P , we get

$$P = Eq \cdot \frac{\sqrt{a}}{4a + 2L + b},$$

which has an absolute maximum with respect to a only; namely,

$$a = \frac{L}{2} + \frac{b}{4}.$$

Substituting this value of a in the last expression for P , we get

$$P = \frac{Eg}{4} \cdot \frac{1}{\sqrt{2L + b}}.$$

Whence it follows that P becomes largest for $b = 0$; otherwise b remains indeterminate. q , on the other hand, should be made as large as possible.

If we now put $v = \frac{r}{q}$, and develop its value from the balance-equation, we get

$$v = \frac{r}{q} = \frac{1}{2} \sqrt{\frac{b}{2L + b}}.$$

The solution of the first problem of the differential method, when the line is perfect in insulation, is therefore

$$h = d = 0,$$

$$f = b = w + \beta,$$

$$a = \frac{L}{2} + \frac{b}{4},$$

$$v = \frac{1}{2} \sqrt{\frac{b}{2L + b}}.$$

The absolute value of b is left indeterminate*, and we only know that the smaller it can be made the better.

But to fulfil this best condition $f = b = w + \beta = 0$ represents a physical impossibility, since neither β , the internal resistance of constant galvanic cells, can be made zero, not even approximately, nor b , which must have convolutions in order to act magnetically.

The larger $f = b = w + \beta$ becomes, for practical reasons, the more the differential method, even under the best quantitative arrangements as given above, will become inefficient as compared with the double balance.

Now by inference we get for a line with leakage, i.e. $i < \alpha$,

* Practically, however, it may be said that b is given; for generally β , the internal resistance of the signalling-battery, is determined by the nature and number of galvanic cells required for duplex working. We must only remember that b should be made somewhat larger than β , in order to have an adjustable resistance r in the battery branch, which may be used for compensating any variation of the battery-resistance, that the equation $f = b = w + \beta$ may be permanently fulfilled.

$$\left. \begin{aligned} a &= \frac{L'}{2} + \frac{b'}{4}, \\ a'' &= \frac{L''}{2} + \frac{b''}{4}, \\ v' &= \frac{1}{2} \sqrt{\frac{b'}{2L' + b'}}, \\ v'' &= \frac{1}{2} \sqrt{\frac{b''}{2L'' + b''}}, \end{aligned} \right\} \text{approximately.}$$

The above values for a and v are somewhat too large; but in practical application they are quite accurate enough.

The physical reason that this solution for the differential method gives an indeterminate result is simply due to the fact that the force which produces the signals in the differential method is due to the combined magnetic actions of *two* separate coils through which unequal currents pass, instead of to *one* coil as in the bridge method. On account of $b=f$, it follows that the current which passes through the b coil is only half of that passing through the a coil. Thus, in order to make the most of the arrived currents, b and f should be both equal to zero, or, in other words, placing all the convolutions in a and *none* in b must clearly give the greatest magnetic force. Obviously, however, such a solution could not fulfil the balance-condition in the sending-station.

The value of b should be chosen as small as practicable; and its minimum value is β , the internal resistance of the signalling battery. How much larger b should be taken depends on the absolute variation of β , *i.e.*, on the constancy of the signalling battery. If the battery is very constant with respect to internal resistance, then b need be only very little larger than β , which determines the adjustable resistance w .

For instance, Minotto cells can be easily prepared with an internal resistance of 10 B.A. U. per single cell. Their minimum resistance, obtained by working, is never less than 5 B.A. U.; and if the zincs are changed from time to time their maximum resistance will scarcely ever be higher than 10 B.A. U.

Hence to make b about 50 per cent. larger than β will suffice, by which, if β is known, the greatest value of w is fixed.

The absolute value of β can be determined from the number of cells which have to be connected up successively, in order to work a given instrument through a given line, when the circuit fig. 2 is adopted. This absolute value of β will therefore not only depend on the electrical state of the line and the nature of the cells, but also on the absolute sensitiveness of the differential instrument employed.

To make β , therefore, as small as possible, a sensitive construction of the differential instrument becomes requisite; further, cells of high electromotive force and low constant resistance are best adapted for forming the signalling-battery. In order to get the widest limits in the variation of w , it is clear that *that* β should be selected which is calculated from the maximum number of cells required to produce the signals with sufficient force. The greatest number of cells is obviously required when the line is at its lowest insulation in India, during the monsoon.

The value $v = \frac{r}{q}$ is what has been termed the mechanical arrangement of the differential instrument.*

If $b = w + \beta$ has been determined by fixing β , then v has its smallest value for L largest, which is the case when the line is perfect in insulation—when the coil a must be closest to the magnetic pole acted upon, and the coil b furthest away from it.

The highest value of v we obtain by substituting the lowest L , *i. e.*, when the line is at its lowest insulation—when the coil b must be nearest to the magnetic point acted upon, and the coil a furthest away from it.

Hence, the two limits of v being fixed by the known limits between which L varies, the extent of movement of the two coils is also fixed; and consequently, if q is chosen arbitrarily, the construction of the differential instrument is determined. But even q is not quite arbitrary, since we know the form, dimensions, and resistance of the coils which, for instance in Siemens's polarized relays on any given line, have to produce the magnetism in single circuit to get the signals with engineering safety.

* Journal of the Asiatic Society of Bengal, vol. xli. part 2, p. 148; Phil. Mag. vol. xlv. p. 166.



**EARTH CURRENT CHART.
BRITISH ISLES.**

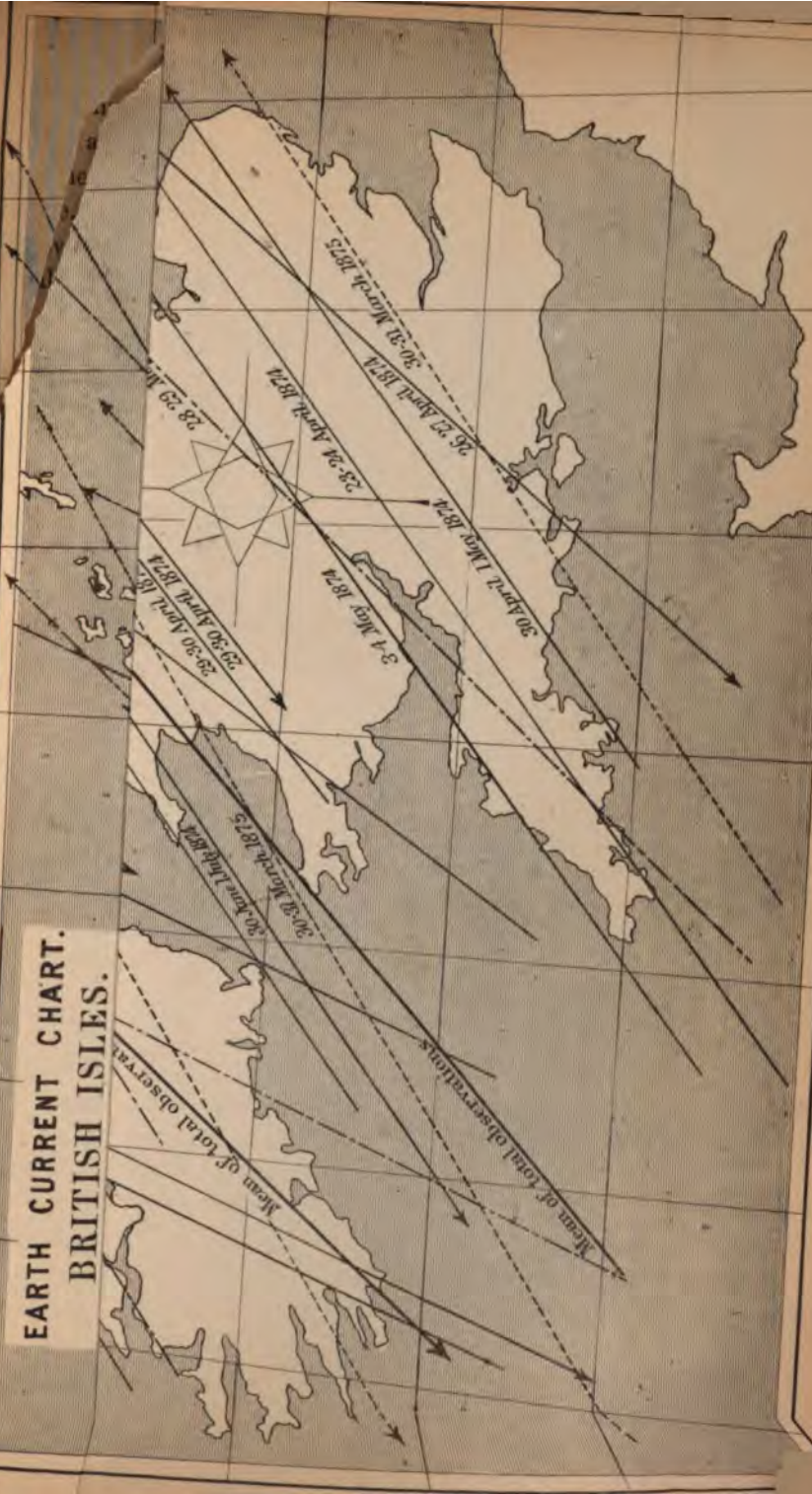

But b largest is required for two separate reasons :

1. If the immediate balance is disturbed by an alteration of the resistance of one or more of the four branches, which may happen especially by f (*i.e.* β , battery resistance) varying, then ρ becomes at once a function of b , *i.e.* an increasing one with b . Thus in order to keep ρ as large as possible and at the same time as constant as possible, b should be selected largest.

2. Further, by making b as large as the circumstances will admit, we clearly have the largest sent and largest received currents—which will be clear without calculation. In fact later on it has been shown that $a = d$ is the condition for the maximum signalling-current.

NOTE.—Since the 3rd of February, 1875, the main line from Bombay to Madras has been successfully worked duplex by means of the “double-balance method.”

This line is worked direct, *i.e.*, without any translating instruments, and is 797 miles in length; it consists almost throughout of No. $5\frac{1}{2}$ wire, B. W. G. (diameter $5\frac{1}{4}$ millims.), and is supported chiefly on the Prussian insulator.

The section of this line from Bombay to Callian is exposed to the destructive influence of a tropical sea climate. Between Callian and Poona the line passes over the Western Ghauts; the dense fogs during the cold weather and the heavy rains during the south-west monsoon on these hills seriously affect its insulation. From Poona to Sholapore and Bellary the line runs inland and experiences a climate on the whole favourable for the maintenance of constant and high insulation. Between Bellary and Madras, however, the line again comes under the influence of a most unfavourable climate, especially just before and during the continuance of the north-east monsoon, when the atmosphere at a high temperature is saturated with moisture and salt, leaving conducting deposits on the surface of the insulators.

Consequently during the south-west monsoon the resultant fault is near Bombay; during the hot weather it shifts towards the middle of the line; and in November, when the rains set in at Madras and the weather on the Bombay side is clearing up, the resultant fault is situated close to Madras.

By February next duplex working will therefore have been submitted to a most severe test, applied as it will have been for a whole year to a long line the electrical condition of which is highly variable with respect to season and locality; and its practicability will doubtless again be clearly proved, as has already been the case on the Calcutta-Bombay line (1,600 miles), where, under no more favourable climatic conditions, duplex has for the past twelve months not only fulfilled but surpassed the expectations formed of it. No difficulties have been experienced, and, it is believed, never will be.

Strange as it may appear from a theoretical point of view, it will nevertheless be found in practice that a line worked duplex carries more than double the traffic of the same line worked singly; for it represents two lines carried on different posts far distant from one another, instead of two parallel lines on the same posts; and consequently the highly injurious effects of voltaic induction are eliminated.

Further, the receiving signallers, not being provided with keys, are unable to interfere with messages during their transmission.

Corrections and repetitions do not necessitate a stoppage of work; for they are obtained in the following manner: The receiving signaller marks with a cross or underlines the words to be repeated, and places the message by the side of the sending signaller, who calls for the repetitions directly he has finished the message he is transmitting; and during this call the distant station may either send fresh messages or may also call for repetitions. Consequently single working need never be resorted to, and the simultaneous exchange of messages and corrections becomes continuous.

The Indian system of receiving (the sounder system, which has now been universally recognised as the only right one for hand-signalling) thus necessitates constant attention on the part of the receiving signallers; for any inattention on their part at once becomes known to the controlling officer.

We extract with pleasure the following from *The Telegraphic Journal* of the 1st January, 1878:—

THE KAFFIR WAR AND THE TELEGRAPH.

We are very glad to find that owing to the able and astute management of Mr. Sivewright, of the Telegraph Department of Cape Colony, the services rendered by it during the late Galeka affair have been such as to elicit a warm acknowledgment of them by the Commissioner of Crown Lands and Public Works, Mr. John Merriman.

We give the text of Mr. Merriman's letter with much pleasure, as it shows how great is the value of a telegraph system properly managed at such moments as that referred to. We trust that the Cape Government will be as ready to acknowledge these services as is their Commissioner, and we congratulate Mr. Sivewright on the energy displayed by him.

“ KING WILLIAM'S TOWN, 12th Nov., 1877.

“ MY DEAR SIR,—I cannot allow you to leave King William's Town without expressing to you the high sense which I entertain of the services rendered by you to the colony during the past trying six weeks. I have no hesitation in saying that to your personal presence in King William's Town has been owing in a great measure the admirable service which the telegraph has been able to perform during the war. Nothing can have exceeded the cheerfulness and skill with which, at a time when frequent interruptions would have been beyond calculation detrimental, you devoted yourself with marked success to the duties of your department with a zeal and tact beyond all praise, and for which I have personally to anticipate the thanks which at a more fitting time the Government will communicate to you.

“ I am, my dear Sir, yours truly,

“ JOHN X. MERRIMAN,

“ Commissioner of Crown Lands and Public Works.

“ J. Sivewright, Esq., Aliwal North.”

APPENDIX.

(Extracted from the *Journal of the Telegraph*.)

Providence, R. I., Nov. 28.

In the *Journal* of November 1st you invite me to describe the conditions under which the telephonic concerts performed in New York, for the benefit of audiences in Saratoga, Troy, and Albany, were overheard in Providence. The circumstances were these. During five evenings in the latter part of August and first part of September performers stationed in the Western Union building in New York sang or played into an Edison Musical Telephone, actuated by a powerful battery, and connected with one or other of the cities above-named by a No. 8-gauge wire, with return through the ground.

In Providence, on the evening of the first of these concerts (August 28th), Henry W. Vaughan, State Assayer, and the writer, were conversing through Bell telephones over a shunt made by grounding one of the American District Telegraph wires in two places, about a quarter of a mile apart, through suitable resistance coils. At about half-past eight o'clock we were surprised by hearing singing on the line, at first faint, but afterwards becoming distinct and clear. At the same moment, apparently, Clarence Rathbone, talking with a friend through Bell telephones over a private line in Albany, was interrupted by the same sounds. Afterwards, during that and subsequent concert evenings, various airs were heard, sung by a tenor or soprano voice, or played on the cornet. The origin of these concerts remained a mystery for some time in Providence, and the lines were watched for music many evenings. The programmes heard proved to be precisely those of the Edison concerts performed in New York, the tenor singers being Signor Tagliapietro and D. W. McAneeny (baritone), and the soprano singer Madame Belle Cole.

The question how this music passed from the New York and Albany wire to a shunt of the District wire in Providence is of scientific importance. The Edison Musical Telephone consists of an instrument converting sound waves into galvanic waves at the transmitting station, and a different instrument reconverting galvanic into sound waves at the receiving station (using the word "wave" in its broadest sense). The battery used in sending the music from New York to Saratoga consisted of 125 cells (carbon-bichromate, No. 1½), with from 1,000 to 3,000 ohms resistance, interposed between the battery and line connections in New York.

Mr. George B. Prescott, to whom I am indebted for these figures, informs me also that the wire used in these concerts extended from the Western Union Building, corner of Broadway and Dey Streets, through Park Row, Chatham Square, the Bowery and Third Avenue, to One Hundred and Thirtieth Street, and thence, *viâ* the Harlem Railroad, to Albany. On the same poles with this Albany wire, for sixteen miles, are supported no less than four wires running to Providence, three of them being on the same cross arm, and one of them being Boston wire No. 55 East, *viâ* Hartford and Providence; also for eight miles a fifth wire, Boston wire No. 32 East, *viâ* New London and Providence. These wires, including the Albany wire, are understood all to have a common ground connection at New York, and to be strung at the usual distance apart, and with the ordinary insulation.

At the Providence end of the line, six New York and Boston wires, No. 55, 32, 2, 5, 27 and 28 East, run into the Western Union Building, in company (on the same poles and brackets), for the last 975 feet, with an American District wire. This last runs especially near to wires 55 and 32, whose proximity to the Albany wire in New York has already been traced above. But here is a distinct feature. The District wire belongs to an exclusively air circuit of four and-a-half miles, having no ground connection. The New York and Albany and New York and Boston wires are or may be grounded at both ends. The District circuit referred to in Providence is geographically two circuits, but electrically one, both working through a single battery of fifteen cells. Mr. Vaughan and myself having "Dis-

trict" boxes, a quarter of a mile apart, on this circuit, made a shunt for telephonic communication by ground connection at each house, including several hundred ohms resistance, so as not to impair the galvanic insulation of the line. The telephone talked through this perfectly, and the sounds of atmospheric electricity were heard in remarkable perfection.

It will be seen that the music from the Albany wire passed first to two or more parallel New York, Providence, and Boston wires; second, from these to a parallel District wire in Providence; and third, through a shunt of that District circuit, before reaching the listeners there.

This transfer of electric wave motion from one wire to another may have taken place by induction, by leakage, or, in the first instance, in New York, by a crowded ground conductor. In the transfer in Providence from the New York and Boston to the District wire there was no common ground connection, and it is difficult to suppose that sufficient leakage took place on the three brackets and three poles, which were common to the New York and the local wire, to account for the transfer in Providence. The Bell telephone has also proved itself abundantly capable of picking up signals in an adjoining wire by induction alone. Without rejecting wholly, therefore, the other modes of transfer, I should ascribe to induction the principal part in the transfer of the concerts from wire to wire between New York and Providence.

What proportion, then, of the electrical music set in motion in New York could have reached the listeners on the shunt in Providence? Whether induction, leakage, or crowded ground was concerned, will any electrician say that the New York and Providence wires situated as described could have robbed the Albany wire of one-tenth or even one-hundredth of its electrical force or motion? When this one-tenth or one-hundredth reached Providence, will any electrician say that the wires from New York in the course of 975 feet could have given up to the parallel District wire one-tenth or one-hundredth of *their* electrical wave motion? Lastly, when the District circuit had secured this minute fraction of the original music-bearing electrical waves, will any electrician say that the shunt as described (containing

500 ohms resistance, while the shunted quarter of a mile of District wire contained only 5 ohms resistance) could have diverted one-tenth of the electric motion from the District circuit?

The music heard plainly in Providence did not therefore require or use one ten-thousandth, hardly one-hundred thousandth, of the electromotive force originally imparted to the Albany wire.

This startling conclusion suggests, first, the wonderful delicacy of the Bell telephone, on which point I shall venture to enlarge, and, second, the as yet unimagined capacity of electricity to transport sound.

The Bell telephone is probably the most sensitive of electroscopes for galvanic, magneto-electric, and atmospheric or free electricity, and will be used extensively in science and the arts in this capacity. In the French Academy, on the 6th of November, M. Breguet introduced the telephone as, of all known instruments, operating under the influence of the most feeble electrical currents. Professor John Pierce, of Providence, has ascertained that the Bell telephone gives audible signals with considerably less than one-hundred thousandth part of the current of a single Leclanché cell. In testing resistances with a Wheatstone bridge the telephone is more sensitive than the galvanometer. In ascertaining the continuity of fine wire coils it gives the readiest answers. For all the different forms of atmospheric electrical discharge—and they are constant and various—the telephone has a language of its own, and opens to research a new field in meteorology.

A Bell telephone in Providence has been found under very favourable conditions to overhear the speech of another Bell telephone on a parallel wire. But it will be noticed that the music and Morse-operating, so noisily overheard on other wires, are not products of the Bell telephone but of powerful galvanic currents. The delicate magneto-electric current of the Bell telephone is not generally exposed to eaves-dropping, unless different sets of wires actually come in contact.

Professor Peirce has observed that if one screw-cup of a Bell telephone is connected with a ground wire, in use at the same time for Morse operating, the Morse signals will be heard in the telephone, although the other screw-cup is disconnected and there

is no circuit. Here the coils of the telephone seem to be momentarily charged by the passing signals, on the principle of a condenser. A still more striking illustration of the electroscopic delicacy of the telephone is this: Professor E. W. Blake, of Brown University, talked with a friend for some distance along a railroad, using the two lines of rails for the telephonic circuit. At the same time he heard the operating on the telegraph wires overhead, caught by the rails, probably by induction.

The absence of insulation in this experiment recalls another curious observation. The Bell telephone works better in some states of the atmosphere than in others. A north-east wind appears specially favourable. When a storm is approaching the sounds are sometimes weak; but the talking is often loud and excellent in the midst of a storm, when insulation is most defective. I have just verified this by talking over a short line where the wire is without insulation, and its only support between two houses, the trunk of a tree, just now sheeted with water from falling rain. This apparent indifference to insulation in a telephone which will overcome a resistance of 11,000 ohms is not easily explained. This is only one of a multitude of paradoxes presented by the Bell telephone.

The sound produced in the telephone by lightning, even when so distant that only the flash can be seen in the horizon, and no thunder can be heard, is very characteristic, something like the quenching of a drop of melted metal in water, or the sound of a distant rocket. The most remarkable circumstance is, that this sound is always heard just *before* the flash is seen—that is, there is a probable disturbance (inductive) of the electricity overhead, due to the distant concentration of electricity *preceding* the disruptive discharge. On Sunday, Nov. 18, these sounds were heard and remarked upon in Providence the first time for several weeks. The papers on Monday morning explained it by the report of thunderstorms in Massachusetts on the preceding day. Frequent sounds of electrical discharge similar to that of lightning, but much fainter, are almost always heard several hours before a thunderstorm. This has just (Nov. 26) been exemplified in Providence.

The sounds produced in the Bell telephone by the auroral flashes

or streamers were observed here by Professor John Pierce in May or June.

I will give one further illustration of the delicacy of the Bell telephone, this time in relation to magnetism. In June last Professor E. W. Blake substituted for the magnet of the telephone a bar of soft iron, free from magnetism. When this was held in the line of the dipping-needle, the telephone talked readily *by the earth's magnetism*. But when the telephone was swayed into a position at right angles with the line of the dipping needle (in the same vertical plane) it was absolutely silent, and the voice increased or faded out in proportion as the telephone was directed toward, or receded from, the pole of the dipping-needle.

It remains only to speak of the quality of the concert music overheard in Providence. The rendering of the music was very perfect, but articulation was deficient or absent, both in the songs and in some sentences which are said to have been declaimed in New York for the amusement of the audiences in Saratoga and elsewhere. The papers of the day report that the words were undistinguishable in Saratoga. There is, therefore, no reason to suppose that the sounds lost anything in quality in the course of their indirect transmission to Providence.

WM. F. CHANNING.

INDEX.

	PAGE
Abel, Professor, C.B., F.R.S., Inaugural Address.....	3
Acting Secretary, Resignation of	160
Adams, A. J. S., On Earth Currents.....	468
" On sonorous properties of Electro static Induction	476
Ailhaud, M., On Duplex Cable-working	205
Annual Report.....	456
Associates advanced to Membership	26, 159, 214, 454, 490
Atmospheric Electricity, Professors Ayrton and Perry, On	242
Antokinetic System, Description of	143
Aylmer, J., On Underground Telegraphs in France	170
Ayrton and Perry, Professors, On a Atmospheric Electricity.....	242
" " On a Duplex partial-earth test	251
" " On Unifilar Suspension	335
Balance Sheet	466
Banker, S. M., On Earth Currents	515
Batteries, F. Roberts, On	257
" Discussion on	273
Bell, Professor A. Graham, Researches in Telephony.....	385
Banest, H., On Sir William Thomson's Deep-Sea Sounding Apparatus.....	320
Brazil, Telegraphy in, Note on.....	520
Brough, R. S., On Wires for long spans	337
" On a case of Lightning	378
Cooke, Sir W. F., Presentation of Portrait of	160
Currents, Measurement of.....	448
Dauids, R. G. B., On Brazilian Telegraphs	520
Double-Current Translation.....	284
Duplex Telegraphy, Theory of.....	360, 534
" Discussion on	209
" M. Ailhaud's system of.....	205
Duplex Partial-Earth Test	251
Earth-Currents, S. M., Banker, On.....	515
" A. J. S. Adams, On.....	468
" Discussion on	475
Electric Telephony, Researches in, by Professor A. G. Bell	385
" Light, Description of, M. Jablochhoff's.....	303
" Discussion on	317
Electro-Magnets, M. Lacoine, On.....	215, 218
Exchange Telegraph Instruments, F. Higgins, On	122
Fire-Telegraphs, R. von F. Treuenfeld, On	75
" Statistics of	96
" Discussion on.....	116, 147
Floyd, W. H., On New Zealand Telegraphs ...	226

	PAGE
Gott, J., On a New Wire-Finder	522
Graves, J., On a New Make-and-Break Arrangement	357
Gray, Elisha, D.Sc., On a New Application of the Telephone	506
Higgins, F., On the Exchange Telegraph Instrument.....	122
Inaugural Address	3
Inductophone, The, A. J. S. Adams, On	476
Jablochkoff's Electric Candle	303
Jamieson, A., On a Combined Key and Switch	330
Key and Switch, A. Jamieson's Combined	330
Lacoiné, M. Emile, On Electro-Magnets.....	215, 218
Langdon, W. E., On M. Jablochkoff's Electric Candle	303
" Appointment as Acting Secretary.....	161
Lightning, Absolute Determination of	378
Long Spans, Wires Over	337
Make-and-Break Arrangement for Siphon Recorder	357
Measurement of Currents, W. H. Preece, On.....	448
" " Discussion on	452
New Members	26, 73, 159, 214, 319, 490
New Zealand Telegraphs	226
Obach, Dr. Engen, On Selenium.....	498
Obituary	492
Officers and Council, Election of.....	488
Preece, W. H., On Shunts.....	27
" " Measurement of Currents.....	448
Prescott, G. B., On Quadruplex Telegraphy	189
Proceedings of Meeting, held 24th January, 1877.....	1
" " 14th February, 1877	27
" " 28th February, 1877	75
" " 14th March, 1877	122
" " 28th March, 1877	160
" " 11th April, 1877	189
" " 25th April, 1877	257
" " 9th May, 1877	284
" " 31st October, 1877	385
" " 28th November, 1877	422
" " 12th December, 1877	456
Quadruplex Telegraphy, G. B. Prescott, On	189
Report, Annual	456
Risch, G., On Double-current Translation	284
Roberts, M. F., On Batteries.....	257
Robinson, Major-General, D. G., Memoir of	492
Ruhmkorff, Daniel Heinrich, Memoir of.....	496
Rules, Modification of	489
Schwendler, L., On Duplex Telegraphy	360, 524
Secretary, Acting, Resignation of	160

INDEX.

	PAGE
Selenium, Willoughby Smith, On	423
„ Dr. Engen Obach, On	498
Shunts, W. H. Preece, On.....	27
„ Law of	29
„ Use of	33, 63
„ Electro-Magnetic Induction in	40
„ Experiments with.....	44
„ Static Induction in	62
„ Ratio of, to Electro-Magnets	69
„ Extra Current in	70
Smith, Willoughby, On Selenium	423
„ On Underground Telegraphs	162
Sonorous Properties of Electrostatic Induction.....	476
Soundings, Deep-Sea, with Sir William Thomson's Apparatus.....	320
Students Advanced to Associateship	455, 490
Telephone, New Application of	506
Telephony, Researches in	385
Treasurer, Resignation of	160
Treuenfeld, R. von F., On Fire Telegraphs	75
Underground Telegraphs, Willoughby Smith, On	162
„ „ in France	170
„ „ Discussion on	177
Unifilar Suspension, Professors Ayrton and Perry, On	335
Wire-Finder, New Form of	522

